Light conveyor belts — Determination of electrical resistances

*Courroies transporteuses légères — Détermination des résistances
électriques*

iTeh Standards
(<https://standards.iteh.ai>)
Document Preview

[ISO 21178:2020](https://standards.iteh.ai/catalog/standards/iso/bef533f2-2b7f-49d9-ad8e-eef687bf4821/iso-21178-2020)

<https://standards.iteh.ai/catalog/standards/iso/bef533f2-2b7f-49d9-ad8e-eef687bf4821/iso-21178-2020>



iTeh Standards
(<https://standards.iteh.ai>)
Document Preview

[ISO 21178:2020](https://standards.iteh.ai/catalog/standards/iso/bef533f2-2b7f-49d9-ad8e-eef687bf4821/iso-21178-2020)

<https://standards.iteh.ai/catalog/standards/iso/bef533f2-2b7f-49d9-ad8e-eef687bf4821/iso-21178-2020>



COPYRIGHT PROTECTED DOCUMENT

© ISO 2020

All rights reserved. Unless otherwise specified, or required in the context of its implementation, no part of this publication may be reproduced or utilized otherwise in any form or by any means, electronic or mechanical, including photocopying, or posting on the internet or an intranet, without prior written permission. Permission can be requested from either ISO at the address below or ISO's member body in the country of the requester.

ISO copyright office
CP 401 • Ch. de Blandonnet 8
CH-1214 Vernier, Geneva
Phone: +41 22 749 01 11
Fax: +41 22 749 09 47
Email: copyright@iso.org
Website: www.iso.org

Published in Switzerland

Contents

	Page
Foreword	v
1 Scope	1
2 Normative references	1
3 Terms and definitions	1
4 Symbols	2
5 Electrical surface resistances	2
5.1 Method A: Measurement of surface resistance, R_{OA} , omni-directionally	2
5.1.1 Applicability	2
5.1.2 Principle	2
5.1.3 Apparatus (see Figure 1)	2
5.1.4 Test piece	4
5.1.5 Procedure	5
5.1.6 Expression of results	6
5.1.7 Test report	6
5.2 Method B: Measurement of surface resistance R_{OB} in longitudinal and transverse directions	6
5.2.1 Applicability	6
5.2.2 Principle	6
5.2.3 Apparatus (see Figure 4)	6
5.2.4 Test piece	8
5.2.5 Procedure	9
5.2.6 Expression of results	9
5.2.7 Test report	9
6 Electrical surface resistivity ρ_s	10
6.1 General	10
6.2 Principle	10
6.3 Apparatus	11
6.4 Test piece	12
6.4.1 Material	12
6.4.2 Dimensions	12
6.4.3 Number	12
6.4.4 Cleaning	12
6.4.5 Conditioning	12
6.4.6 Preparation	12
6.5 Procedure	12
6.6 Expression of results	13
6.7 Test report	13
7 Electrical volume resistances	13
7.1 Volume resistance, R_D , perpendicular to plane of belt	13
7.1.1 Principle	13
7.1.2 Apparatus	13
7.1.3 Test piece	14
7.1.4 Procedure	15
7.1.5 Expression of results	15
7.1.6 Test report	15
7.2 Volume resistance, R_{Di} , in longitudinal and transverse directions parallel to plane of belt	16
7.2.1 Principle	16
7.2.2 Apparatus	16
7.2.3 Test piece	17
7.2.4 Procedure	18
7.2.5 Expression of results	19

7.2.6	Test report.....	19
8	Electrical volume resistivity, ρ_D	19
8.1	Procedure.....	19
8.2	Expression of results.....	19
8.3	Test report.....	20
	Bibliography	21

iTeh Standards
(<https://standards.itih.ai>)
Document Preview

[ISO 21178:2020](https://standards.itih.ai/catalog/standards/iso/bef533f2-2b7f-49d9-ad8e-eef687bf4821/iso-21178-2020)

<https://standards.itih.ai/catalog/standards/iso/bef533f2-2b7f-49d9-ad8e-eef687bf4821/iso-21178-2020>

Foreword

ISO (the International Organization for Standardization) is a worldwide federation of national standards bodies (ISO member bodies). The work of preparing International Standards is normally carried out through ISO technical committees. Each member body interested in a subject for which a technical committee has been established has the right to be represented on that committee. International organizations, governmental and non-governmental, in liaison with ISO, also take part in the work. ISO collaborates closely with the International Electrotechnical Commission (IEC) on all matters of electrotechnical standardization.

The procedures used to develop this document and those intended for its further maintenance are described in the ISO/IEC Directives, Part 1. In particular, the different approval criteria needed for the different types of ISO documents should be noted. This document was drafted in accordance with the editorial rules of the ISO/IEC Directives, Part 2 (see www.iso.org/directives).

Attention is drawn to the possibility that some of the elements of this document may be the subject of patent rights. ISO shall not be held responsible for identifying any or all such patent rights. Details of any patent rights identified during the development of the document will be in the Introduction and/or on the ISO list of patent declarations received (see www.iso.org/patents).

Any trade name used in this document is information given for the convenience of users and does not constitute an endorsement.

For an explanation of the voluntary nature of standards, the meaning of ISO specific terms and expressions related to conformity assessment, as well as information about ISO's adherence to the World Trade Organization (WTO) principles in the Technical Barriers to Trade (TBT) see www.iso.org/iso/foreword.html.

This document was prepared by Technical Committee ISO/TC 41, *Pulleys and belts (including veebelts)*, Subcommittee SC 3, *Conveyor belts*, in collaboration with the European Committee for Standardization (CEN) Technical Committee CEN/TC 188, *Conveyor belts*, in accordance with the Agreement on technical cooperation between ISO and CEN (Vienna Agreement).

This third edition cancels and replaces the second edition (ISO 21178:2013), which has been technically revised. The main changes compared to the previous edition are as follows:

- addition of terms and definitions;
- modifications to the figures and formulas;
- technical changes to the [Clauses 5, 6 and 7](#);
- deletion of Annex A;
- editorial modifications.

Any feedback or questions on this document should be directed to the user's national standards body. A complete listing of these bodies can be found at www.iso.org/members.html.

Light conveyor belts — Determination of electrical resistances

1 Scope

This document specifies test methods for determining the electrical resistances of light conveyor belts according to ISO 21183-1. The resistances are surface resistance, volume resistance perpendicular to the belt plane, and longitudinal and transverse volume resistance parallel to the belt plane. This document also specifies two test methods for determining the surface resistivity and the volume resistivity.

2 Normative references

The following documents are referred to in the text in such a way that some or all of their content constitutes requirements of this document. For dated references, only the edition cited applies. For undated references, the latest edition of the referenced document (including any amendments) applies.

ISO 18573, *Conveyor belts — Test atmospheres and conditioning periods*

3 Terms and definitions

For the purposes of this document, the following terms and definitions apply.

ISO and IEC maintain terminological databases for use in standardization at the following addresses:

— ISO Online browsing platform: available at <https://www.iso.org/obp>

— IEC Electropedia: available at <http://www.electropedia.org/>

3.1

electrical surface resistance

quotient of a direct-current voltage applied between two electrodes on the same surface of a test piece and the current between the electrodes

Note 1 to entry: It is expressed in ohms (Ω).

3.2

electrical surface resistivity

measured surface resistance calculated to apply to a square

Note 1 to entry: It is expressed in ohms (Ω) and the size of the square is immaterial.

3.3

electrical volume resistance

quotient of a direct-current voltage applied between two electrodes in contact with opposite faces of a test piece and the current between the electrodes, excluding current along the surface

Note 1 to entry: It is expressed in ohms (Ω).

3.4

electrical volume resistivity

measured volume resistance calculated to apply to a cube of unit side

Note 1 to entry: It is expressed in ohm metres (Ωm).

4 Symbols

Symbol	Description	Unit
R_{OA}	Electrical surface resistance, method A	Ω
R_{OB}	Electrical surface resistance, method B	Ω
R_{OG}	Electrical surface resistance for the determination of ρ_s	Ω
R_D	Electrical volume resistance perpendicular to the plane of the belt	Ω
R_{Di}	Electrical volume resistance in longitudinal and transverse direction parallel to the plane of the belt	Ω
ρ_s	Electrical surface resistivity	Ω
ρ_D	Electrical volume resistivity	Ωm
$d_{1/2/3}$	Diameter of electrode	mm
d_m	Middle of the gap diameter	mm
g	Width of the gap	mm
A	Surface of the electrode	mm^2
$h_{1/2}$	Thickness of test piece	mm

NOTE The SI unit of surface resistivity, ρ_s , is the ohm (Ω). In practice, this is sometimes referred to as “ohm/square” or “ Ω/sq ”. The size of the square is immaterial.

5 Electrical surface resistances

5.1 Method A: Measurement of surface resistance, R_{OA} , omni-directionally

5.1.1 Applicability

This method is applicable to belts which are electrically two-dimensionally isotropic in the plane of the belt.

5.1.2 Principle

An electric current of specified voltage is passed via electrodes through a suitably prepared test piece taken from the belt.

5.1.3 Apparatus (see [Figure 1](#))

5.1.3.1 Sheet of insulating material, a little larger than the test piece.

5.1.3.2 Two cylindrical and coaxial electrodes (see [Figure 1](#)), with contact surfaces machined flat and polished, as follows.

5.1.3.2.1 Electrode 1, circular.

5.1.3.2.2 Electrode 2, annular.

5.1.3.2.3 Material of electrodes, either brass or stainless steel.

5.1.3.3 Ohmmeter, having a measuring range up to $10^{10} \Omega$ and accurate to within $\pm 5\%$.

5.1.3.4 **Source of direct current**, adjustable up to 500 V, and not permitting a current greater than 10 mA.

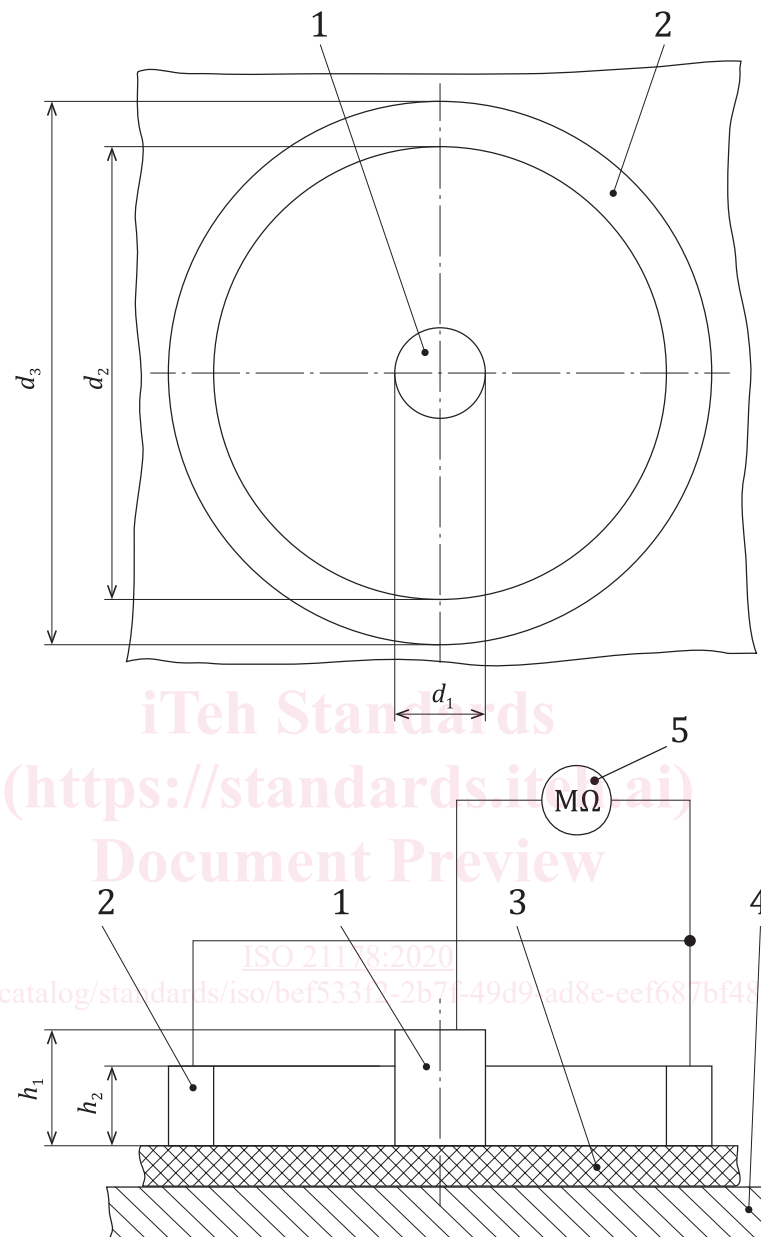

Key

- 1 electrode 1
- 2 electrode 2
- 3 test piece
- 4 sheet of insulating material
- 5 ohmmeter

Figure 1 — Test arrangement for measurement of electrical surface resistance R_{OA}

5.1.4 Test piece

5.1.4.1 Material

Test piece material shall be new, unused (“virgin”), but shall not be tested sooner than five days after manufacture. It shall be free from contamination and superficial damage.

5.1.4.2 Dimensions

The test pieces shall be square, 300 mm × 300 mm minimum, and shall be cut from the full thickness of the belt.

5.1.4.3 Number

Three test pieces shall be taken. One test piece shall be taken from the middle of the belt, the other two test pieces shall be taken in the area between 100 mm to 400 mm from each of the belt edges. The test pieces shall be selected in accordance with [Figure 2](#).

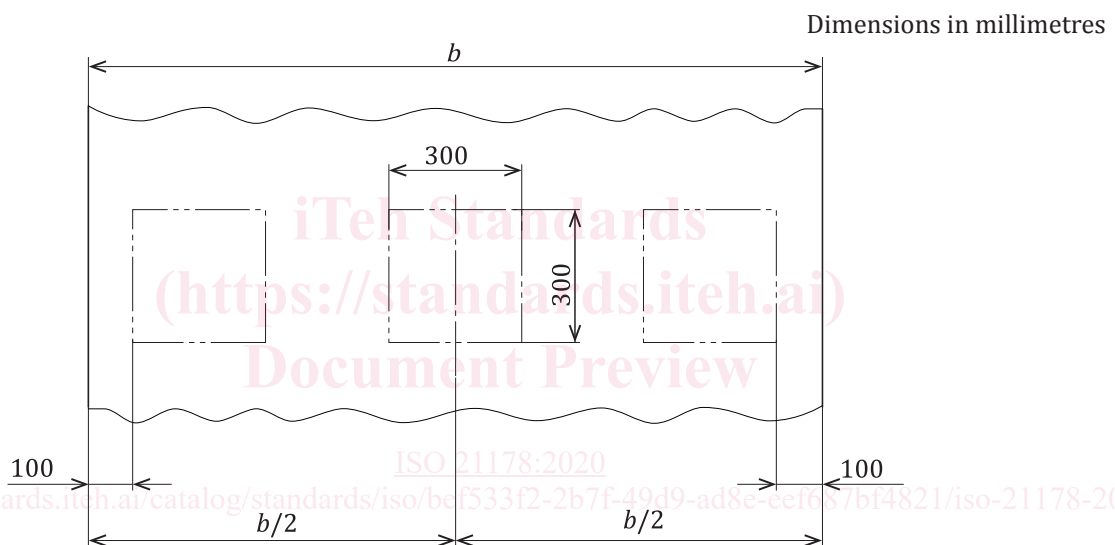

Key

b belt width

Figure 2 — Distribution of test piece selection

5.1.4.4 Cleaning

If necessary, clean both surfaces of the test pieces by rubbing with fuller's earth (hydrated magnesium-aluminium silicate), for example, using a clean cloth. After cleaning away all traces of the powder, wipe the surface with a clean cloth moistened with distilled water and then dry with a clean cloth.

5.1.4.5 Conditioning

Before testing, condition the test pieces in accordance with ISO 18573, Atmosphere B, for 24 h, except that, if the light conveyor belt consists of materials with a high absorption of moisture, for example cotton or polyamide, condition the test piece for 48 h.

5.1.4.6 Preparation

To ensure good contact between electrodes and test piece a contact medium as described in [5.1.4.7](#) can be used if necessary.