

FINAL
DRAFT

INTERNATIONAL
STANDARD

ISO/FDIS
23598

ISO/TC 44/SC 6

Secretariat: DIN

Voting begins on:
2020-11-13

Voting terminates on:
2021-01-08

Mechanical joining of sheet materials — Destructive testing of joints — Specimen dimensions and procedure for mechanized peel testing of single joints

iTeh STANDARD PREVIEW
(standards.iteh.ai)

[ISO/FDIS 23598](#)

<https://standards.iteh.ai/catalog/standards/sist/f46ad3c8-e4e6-4f21-8e0a-82729daa421e/iso-fdis-23598>

Member bodies are requested to consult relevant national interests in ISO/TC 2 before casting their ballot to the e-Balloting application.

RECIPIENTS OF THIS DRAFT ARE INVITED TO SUBMIT, WITH THEIR COMMENTS, NOTIFICATION OF ANY RELEVANT PATENT RIGHTS OF WHICH THEY ARE AWARE AND TO PROVIDE SUPPORTING DOCUMENTATION.

IN ADDITION TO THEIR EVALUATION AS BEING ACCEPTABLE FOR INDUSTRIAL, TECHNOLOGICAL, COMMERCIAL AND USER PURPOSES, DRAFT INTERNATIONAL STANDARDS MAY ON OCCASION HAVE TO BE CONSIDERED IN THE LIGHT OF THEIR POTENTIAL TO BECOME STANDARDS TO WHICH REFERENCE MAY BE MADE IN NATIONAL REGULATIONS.



Reference number
ISO/FDIS 23598:2020(E)

© ISO 2020

iTeh STANDARD PREVIEW
(standards.iteh.ai)

ISO/FDIS 23598

<https://standards.iteh.ai/catalog/standards/sist/f46ad3c8-e4e6-4f21-8e0a-82729daa421e/iso-fdis-23598>



COPYRIGHT PROTECTED DOCUMENT

© ISO 2020

All rights reserved. Unless otherwise specified, or required in the context of its implementation, no part of this publication may be reproduced or utilized otherwise in any form or by any means, electronic or mechanical, including photocopying, or posting on the internet or an intranet, without prior written permission. Permission can be requested from either ISO at the address below or ISO's member body in the country of the requester.

ISO copyright office
CP 401 • Ch. de Blandonnet 8
CH-1214 Vernier, Geneva
Phone: +41 22 749 01 11
Email: copyright@iso.org
Website: www.iso.org

Published in Switzerland

Contents

	Page
Foreword	iv
1 Scope	1
2 Normative references	1
3 Terms and definitions	1
4 Test pieces and test specimens	3
5 Preparation of mechanized peel test specimens	4
5.1 General	4
5.2 Bending procedure for preparation of peel test specimens	4
5.3 Dimensions and accuracy of bent radius	6
6 Testing procedure and test equipment	6
7 Type of failure mode	7
8 Re-test	7
9 Test report	8
Annex A (normative) Type of joint failure in mechanized peel testing	9
Annex B (informative) Examples of bending tools	12
Annex C (informative) Determination of bending centre position with the press brake system	14
Bibliography	15

iTech STANDARD PREVIEW
(standards.iteh.ai)

[ISO/FDIS 23598](https://standards.iteh.ai/catalog/standards/sist/f46ad3c8-e4e6-4f21-8e0a-82729daa421e/iso-fdis-23598)

<https://standards.iteh.ai/catalog/standards/sist/f46ad3c8-e4e6-4f21-8e0a-82729daa421e/iso-fdis-23598>

Foreword

ISO (the International Organization for Standardization) is a worldwide federation of national standards bodies (ISO member bodies). The work of preparing International Standards is normally carried out through ISO technical committees. Each member body interested in a subject for which a technical committee has been established has the right to be represented on that committee. International organizations, governmental and non-governmental, in liaison with ISO, also take part in the work. ISO collaborates closely with the International Electrotechnical Commission (IEC) on all matters of electrotechnical standardization.

The procedures used to develop this document and those intended for its further maintenance are described in the ISO/IEC Directives, Part 1. In particular, the different approval criteria needed for the different types of ISO documents should be noted. This document was drafted in accordance with the editorial rules of the ISO/IEC Directives, Part 2 (see www.iso.org/directives).

Attention is drawn to the possibility that some of the elements of this document may be the subject of patent rights. ISO shall not be held responsible for identifying any or all such patent rights. Details of any patent rights identified during the development of the document will be in the Introduction and/or on the ISO list of patent declarations received (see www.iso.org/patents).

Any trade name used in this document is information given for the convenience of users and does not constitute an endorsement.

For an explanation of the voluntary nature of standards, the meaning of ISO specific terms and expressions related to conformity assessment, as well as information about ISO's adherence to the World Trade Organization (WTO) principles in the Technical Barriers to Trade (TBT), see www.iso.org/iso/foreword.html.

This document was prepared by Technical Committee ISO/TC 44, *Welding and allied processes*, Subcommittee SC 6, *Resistance welding and allied mechanical joining*.

Any feedback or questions on this document should be directed to the user's national standards body. A complete listing of these bodies can be found at www.iso.org/members.html.

Official interpretations of ISO/TC 44 documents, where they exist, are available from this page: <https://committee.iso.org/sites/tc44/home/interpretation.html>.

Mechanical joining of sheet materials — Destructive testing of joints — Specimen dimensions and procedure for mechanized peel testing of single joints

1 Scope

This document specifies the geometry of test specimens and the testing procedure for mechanized peel testing of single mechanical joints on single-lap test specimens up to a single sheet thickness of 4,5 mm.

The term “sheet”, as used in this document, includes extrusions and cast materials.

The purpose of the mechanized peel tests is to determine the mechanical characteristics and the failure modes of the joints made with different joining methods.

This document does not apply to civil engineering applications such as metal buildings and steel constructions which are covered by other application standards.

NOTE For mechanized peel testing of resistance spot, seam and embossed projection welds, see ISO 14270

2 Normative references

There are no normative references in this document.

3 Terms and definitions

For the purposes of this document, the following terms and definitions apply.

ISO and IEC maintain terminological databases for use in standardization at the following addresses:

- ISO Online browsing platform: available at <https://www.iso.org/obp>
- IEC Electropedia: available at <http://www.electropedia.org/>

3.1

mechanized peel strength

MPS

F_{\max}

maximum peel force (3.2) obtained from mechanized peel testing

3.2

peel force

F

force/load which is applied to the test specimen during mechanized peel testing

3.3

slippage force

F_{sl}

peel force (3.2)/load at which slippage occurs if the phenomenon is observed during testing

3.4

specimen deformation

s

crosshead displacement during testing

3.5 specimen deformation at maximum load

$S_{F_{max}}$
specimen deformation (3.4) at which the maximum peel force (3.2)/load F_{max} is recorded

Note 1 to entry: See Figure 4 and Figure 5

3.6 specimen deformation at 0,3 F_{max}

$S_{0,3F_{max}}$
specimen deformation (3.4) at which $0,3F_{max}$ is recorded

Note 1 to entry: See Figure 4 and Figure 5

3.7 specimen deformation at fracture

$S_{fracture}$
specimen deformation (3.4) of at which fracture occurs

Note 1 to entry: See Figure 4 and Figure 5

3.8 dissipated energy

W
amount of energy dissipated until a displacement point under the load-crosshead displacement curve

[SOURCE: ISO 12161, 3.4.1]

iTeh STANDARD PREVIEW
(standards.iteh.ai)

3.9 dissipated energy up to F_{max}

$W_{F_{max}}$
dissipated energy or work calculated by integrating the area under the crosshead displacement curve up to the point at which maximum peel load (MPS point) is recorded

$$W_{F_{max}} = \int_0^{S_{F_{max}}} F ds$$

3.10 dissipated energy up to 0,3 F_{max}

$W_{0,3F_{max}}$
dissipated energy or work calculated by integrating the area under the crosshead displacement curve up to the point where the peel force drops to 30 % of the MPS value, F_{max}

$$W_{0,3F_{max}} = \int_0^{S_{0,3F_{max}}} F ds$$

Note 1 to entry: See Clause 6

3.11 dissipated energy up to fracture

$W_{fracture}$
dissipated energy calculated by integrating the crosshead displacement curve up to the point at which fracture occurs

$$W_{fracture} = \int_0^{S_{fracture}} F ds$$

4 Test pieces and test specimens

Table 1 and Figure 1 give the dimensions and form of test coupons and test specimens for mechanized peel testing, and the location of mechanical joint. The positional accuracy of the mechanical joints on the test specimen shall be ± 1 mm in every direction.

Table 1 — Test specimen dimensions and joint position

Dimensions in millimetres

Thickness t	Flange length a	Specimen width b	Coupon length ^a l_s	Free length between clamps ^a l_f	Edge distance e
$0,5 < t \leq 4,5$	50	50	100	30	25
			≥ 160	105	

^a The shorter coupon length (before joining) is preferred but a longer specimen can be needed based on joining process limitations or for comparison with results from testing in accordance with ISO 14270.

The test specimen for mechanical joints shall be produced as a single joint specimen as shown in Figure 1 b), which is made of two coupons shown in Figure 1 a), and then the mechanized peel test specimen shall be mounted on a tensile test machine as shown in Figure 1 c).

In the case of unequal sheet thicknesses, the test specimen dimensions shall be based on the thinner sheet. Mechanized peel testing shall be made by the procedure specified in Clause 5 and Clause 6.

The tolerances on the dimensions shall be in accordance with Table 2.

ITeH STANDARD PREVIEW
(standards.iteh.ai)

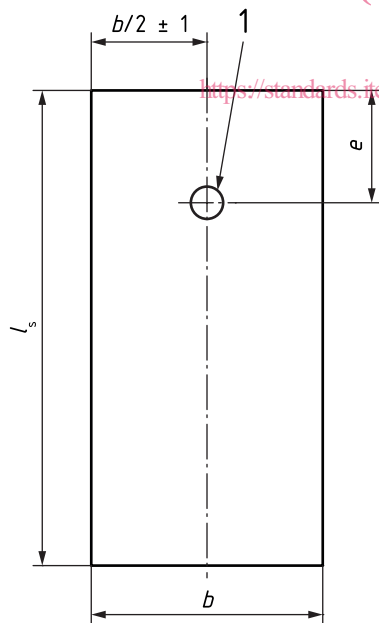

a) Test coupons

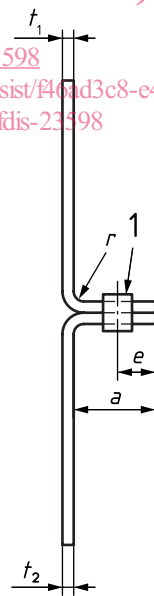

b) Test specimen

Dimensions in millimetres

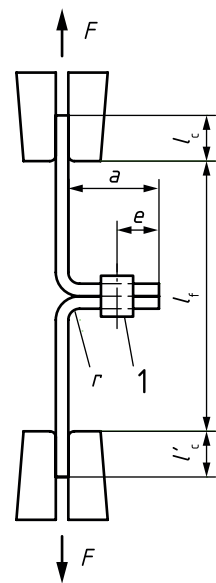

c) After clamped by a testing machine

Key

1	joint/fastener	<i>a</i>	flange length
l_s	coupon length	<i>r</i>	bending radius
l_f	free length between clamps	<i>b</i>	coupon/specimen width
l_c, l'_c	clamping length	<i>e</i>	edge distance
<i>F</i>	applied force (load)		

Figure 1 — Test coupons, test specimens and the clamping state for mechanized peel testing

Table 2 — Tolerances on dimensions for mechanized peel test specimens

Dimensions in millimetres

Flange length	Coupon/ specimen width	Edge distance	Coupon length	Free length be- tween clamps	Bend radius
<i>a</i>	<i>b</i>	<i>e</i>	l_s	l_f	<i>r</i>
+1,0 0	+1 0	+0,5 0	0 -1	0 -1	$\pm 0,5t^a$

^a *t* is the sheet thickness of each coupon.

5 Preparation of mechanized peel test specimens

iTeh STANDARD PREVIEW
(standards.iteh.ai)

5.1 General

The mechanized peel test specimens for mechanical joints are recommended to be made in the following sequence, so that the test specimens can be tested using a tensile test machine;

Bending → Mechanical joining → Mechanized peel testing

The sequence is called “joining-after-bending process”.

NOTE In resistance spot welding, the bending-after-welding process (Joining → Bending → Mechanized peel testing) can be used, but in the case of mechanical joining, some fasteners cannot be tested using this sequence as the fastener interferes with the clamping face for bending after joining, or the clamping device can influence the joint part properties.

5.2 Bending procedure for preparation of peel test specimens

The test coupons shall be bent before mechanical joining as shown in [Figure 2](#).

The recommended set-up conditions of jigs for bending with a press brake are shown in [B.1](#).

NOTE When setting the value $l_b = a$ as shown in [Figure 2](#), the maximum error in the flange length is less than $\pm 0,5$ mm if $r = 2t$ and $t \leq 4,5$ mm (see detail in [Annex C](#)).

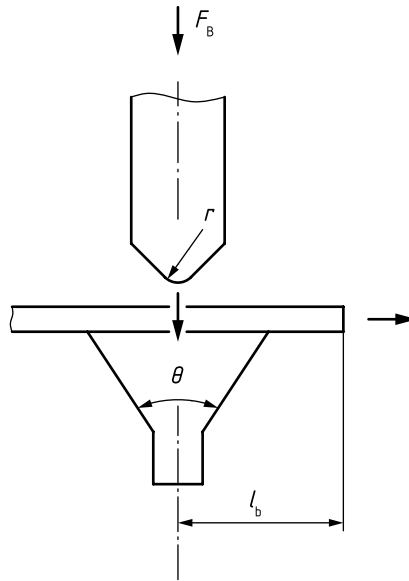

Key

F_B	bending force	r	radius of bent corner/bend radius
l_b	centre of bending (= a , flange length, see Figure 1)	θ	angle

Figure 2 — Bending process with a press brake for test coupons

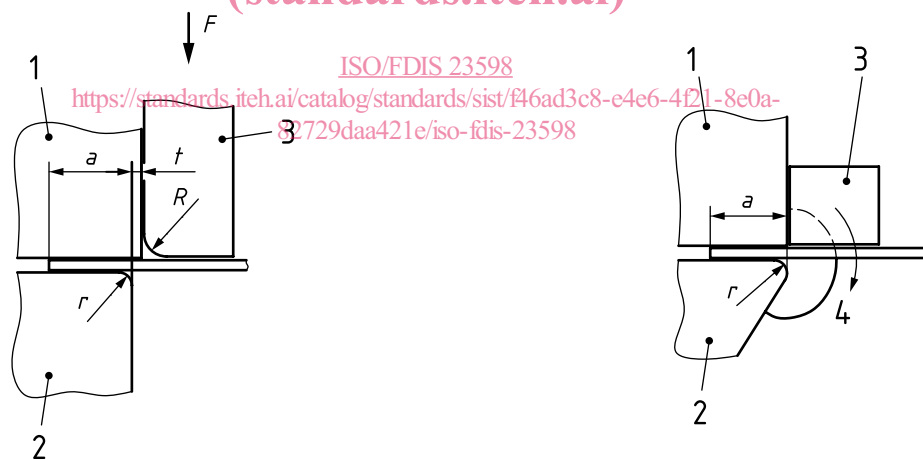

a) Using a wiping die

b) Using a cornice brake

Key

1	upper jaw	F	force
2	lower jaw	r	radius of bent corner
3	die	R	edge radius of die
4	rotating	a	flange length

Figure 3 — Examples of edge bending

A mechanized press brake system is generally recommended for the bending although a manual press brake can be used to bend test coupons for soft and thinner test pieces. Other bending tools shown in [Figure 3](#) are also applicable to make the test coupons. The wiping die and cornice brake system can be used. An example of edge bending is shown in [Annex B](#).

5.3 Dimensions and accuracy of bent radius

The value of the inner radius, r , shall be set so that no large and deep cracking occurs during bending on the inner or outer surfaces of the bent corner. The radius value tested shall be recorded. The inner radius r , equal to approximately $2t$ (t , plate thickness) is recommended. Tolerances shall be in accordance with [Table 2](#).

If any cracks are visible, with up to $\times 5$ magnification, after bending in accordance with [5.2](#), new test specimens/coupons with larger inner radii shall be made. The value of the inner radius shall be increased until no cracking occurs on the outer side of the bend.

6 Testing procedure and test equipment

The test specimen is clamped in a tensile testing machine which satisfies the requirements of ISO 7500-1, such that the clamps are at the required distance from one another as shown in [Figure 1 c](#)). Force and crosshead displacement shall be measured simultaneously during testing, and the measuring accuracy shall be $\pm 1\%$. All tests shall be performed at room temperature until the joint fails.

If a special clamping device is used, the shape and size shall be specified in a joining procedure specification (JPS) document, and recorded.

The crosshead displacement rate of the testing machine shall be equal to 10 mm/min or less, and shall be kept constant during testing.

The specimen deformation shall be measured either as the crosshead displacement, or by using an appropriate displacement sensing device directly at the specimen. When using a signal from the crosshead position, it should be corrected for the stiffness of the testing machine. Results can only be compared when performed under similar displacement measuring conditions. The type of measurement and the initial measured length shall be noted in the test report.

The signals for load and specimen deformation during testing shall be recorded as shown in [Figure 4](#), so that at least the peak value of the maximum force is recorded as the MPS in the test report.

NOTE 1 If required, further characteristic data, e.g. $W_{F_{max}}$, $W_{0,3F_{max}}$ and $W_{fracture}$, etc. can be determined from the load-elongation curve (see [Figure 4](#)).

Test specimens for mechanized peel testing, as shown in [Figure 2b](#)), shall be made with a mechanical joining machine. The recommended set-up conditions of jigs for bending with a press brake are shown in [B.1](#).

NOTE 2 When setting the value $l_b = a$ as shown in [Figure 2](#), the maximum error in the flange length is less than $\pm 0,5$ mm if $r = 2t$ and $t \leq 4,5$ mm (see detail in [Annex C](#)).

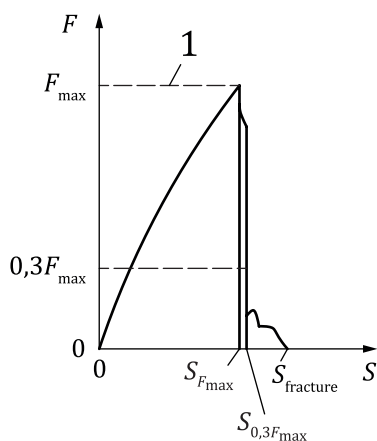

b) Example 1

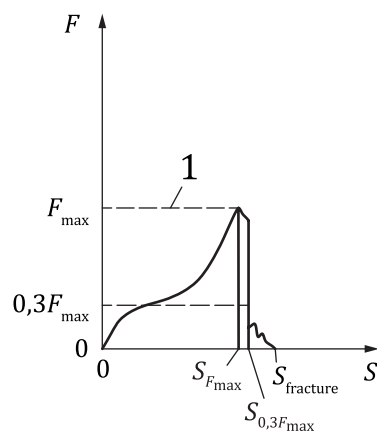

b) Example 2

Key

1	mechanized peel strength	$S_{F_{max}}$	specimen deformation at maximum load
F	load /applied force	$S_{0,3 F_{max}}$	specimen deformation at $0,3 F_{max}$
s	elongation/crosshead displacement	$S_{fracture}$	specimen deformation of at which fracture occurs
F_{max}	mechanized peel strength		

Figure 4 — Examples of load-elongation/crosshead displacement curves without slippage (not to scale)

If slippage occurs during the mechanized peel test (See [Figure 5](#)), the slippage load is also recorded in the test report.

NOTE 3 If slippage occurs, an accurate calculation of the dissipated energy is not possible with the formulae given in [3.9](#) to [3.11](#).

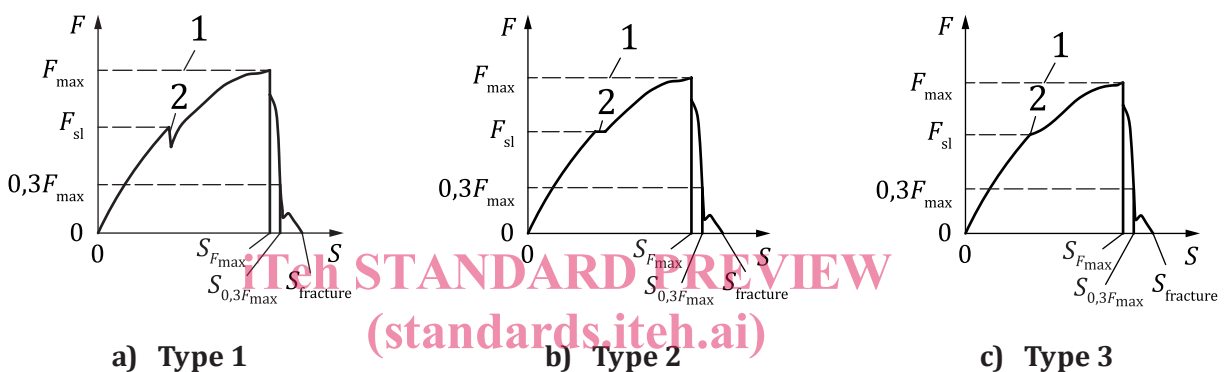

Key

1	mechanized peel strength	F_{sl}	slippage force
2	slippage	$S_{F_{max}}$	specimen deformation at maximum load
F	load/applied force	$0,3 F_{max}$	specimen deformation at $0,3 F_{max}$
F_{max}	mechanized peel strength	$S_{fracture}$	specimen deformation of at which fracture occurs
s	elongation/crosshead displacement		

Figure 5 — Examples of possible slippage recorded on the load-elongation curves (not to scale)

7 Type of failure mode

The type of failure mode after mechanized peel testing shall be classified in accordance with [Annex A](#), and recorded in the test report.

8 Re-test

If fracture occurs only from the bent corner of test specimens during mechanized peel testing in accordance with [Clause 6](#), all mechanized test results shall be disregarded, and new test specimens with larger inner radius shall be made and tested. The value of the inner radius shall be increased until no fracture occurs from the bent part, especially the location of cracks appearing on the bent corner of test specimens. When using larger radii, the radius value tested shall be recorded.

If slippage occurs during the peel test and the slippage load is lower than the required value, re-tests are required with new test specimens after a re-design of the joints, re-selection of the joining technology and/or an improved joining process.