



Designation: D5167 – 10

Standard Practice for Melting of Hot-Applied Joint and Crack Sealant and Filler for Evaluation¹

This standard is issued under the fixed designation D5167; the number immediately following the designation indicates the year of original adoption or, in the case of revision, the year of last revision. A number in parentheses indicates the year of last reapproval. A superscript epsilon (ϵ) indicates an editorial change since the last revision or reapproval.

1. Scope

1.1 This practice establishes the procedure for melting or heating, or both, of hot-applied joint and crack sealants and fillers in preparation for the making of test specimens used in the laboratory evaluations of the sealants and fillers. Refer to the specific standard material specification for sampling requirements, test sample quantity, temperatures and times for melting and heating, and the number of specimens required for testing.

1.2 This practice is applicable to the hot-applied joint and crack sealants and fillers used in both portland cement and asphaltic-concrete pavements.

1.3 The values stated in either SI units or inch-pound units are to be regarded separately as standard. The values stated in each system may not be exact equivalents; therefore, each system shall be used independently of the other. Combining values from the two systems may result in non-conformance with the standard.

1.4 **WARNING**—Mercury has been designated by EPA and many state agencies as a hazardous material that can cause central nervous system, kidney and liver damage. Mercury, or its vapor, may be hazardous to health and corrosive to materials. Caution should be taken when handling mercury and mercury containing products. See the applicable product Material Safety Data Sheet (MSDS) for details and EPA's website – <http://www.epa.gov/mercury/faq.htm> - for additional information. Users should be aware that selling mercury and/or mercury containing products into your state may be prohibited by state law.

1.5 *This standard does not purport to address all of the safety concerns, if any, associated with its use. It is the responsibility of the user of this standard to establish appropriate safety and health practices and determine the applicability of regulatory limitations prior to use.* For specific precautions see Section 7.

¹ This practice is under the jurisdiction of ASTM Committee D04 on Road and Paving Materials and is the direct responsibility of Subcommittee D04.33 on Formed In-Place Sealants for Joints and Cracks in Pavements.

Current edition approved Dec. 1, 2010. Published March 2011. Originally approved in 1991. Last previous edition approved in 2003 as D5167 – 03. DOI: 10.1520/D5167-10.

2. Referenced Documents

2.1 ASTM Standards:²

D5535 Terminology Relating to Formed-in-Place Sealants for Joints and Cracks in Pavements (Withdrawn 2009)³

E1 Specification for ASTM Liquid-in-Glass Thermometers
E220 Test Method for Calibration of Thermocouples By Comparison Techniques

E171 Practice for Conditioning and Testing Flexible Barrier Packaging

3. Terminology

3.1 *Definitions*—Refer to Terminology D5535 for definitions of the following terms used in this specification: *maximum heating temperature*, *minimum application temperature*.

4. Significance and Use

4.1 It is intended that this practice be used by manufacturers, users, and testing agencies. The use of this practice establishes a uniform procedure for the melting or heating of hot-applied sealants and fillers. It is not intended to establish test procedures or conditions of test which are associated with each of the joint sealants and fillers.

5. Standard Conditions

5.1 The laboratory atmospheric conditions, hereinafter referred to as standard conditions, shall be as detailed in Specification E171, $23 \pm 2^\circ\text{C}$ ($73.4 \pm 3.6^\circ\text{F}$) and 50 % relative humidity ± 5 %. The material shall be conditioned for 24 h at standard conditions before melting or heating.

6. Apparatus

6.1 Laboratory Melter:

6.1.1 The equipment for melting of the joint sealant or filler shall be an oil jacketed melter equipped with a mechanical agitator for the oil bath and material in the melting vat.

² For referenced ASTM standards, visit the ASTM website, www.astm.org, or contact ASTM Customer Service at service@astm.org. For *Annual Book of ASTM Standards* volume information, refer to the standard's Document Summary page on the ASTM website.

³ The last approved version of this historical standard is referenced on www.astm.org.

6.1.2 The heat transfer oil shall be a high flash point oil, that is, in excess of 315°C (600°F).

6.1.3 The heat source shall be thermostatically controlled and capable of maintaining the heat transfer oil temperature within a tolerance of $\pm 3^{\circ}\text{C}$ ($\pm 5^{\circ}\text{F}$) and capable of heating the oil to a maximum of 288°C (550°F).

6.1.4 The mechanical agitator speed for the material shall be 30 ± 5 rpm when fully loaded and the agitator speed for the oil bath shall be such to allow continuous circulation of the oil.

6.1.5 Except when adding the sealant or filler sample, or checking temperature, the melter's pots shall be covered with close fitting lids.

6.1.6 Refer to Fig. 1 and Fig. 2 (bottom discharge type) and Fig. 3 (removable can type) for typical laboratory melters. Also see Note 1.

6.1.7 The thermometric device shall be a Type K thermocouple with resolution of 1°C and the calibration verified in accordance with Test Method E220 at least once per year. Use

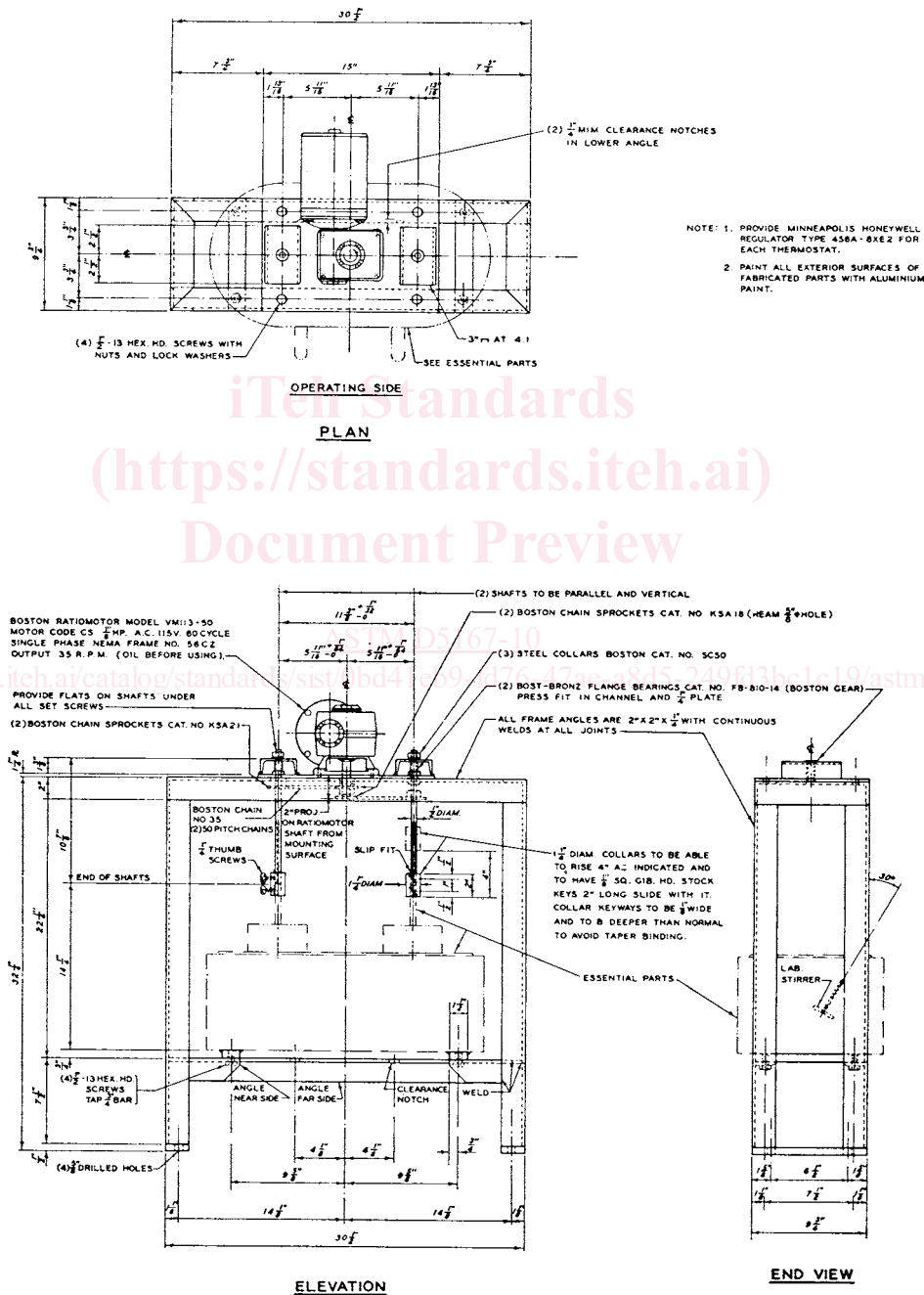

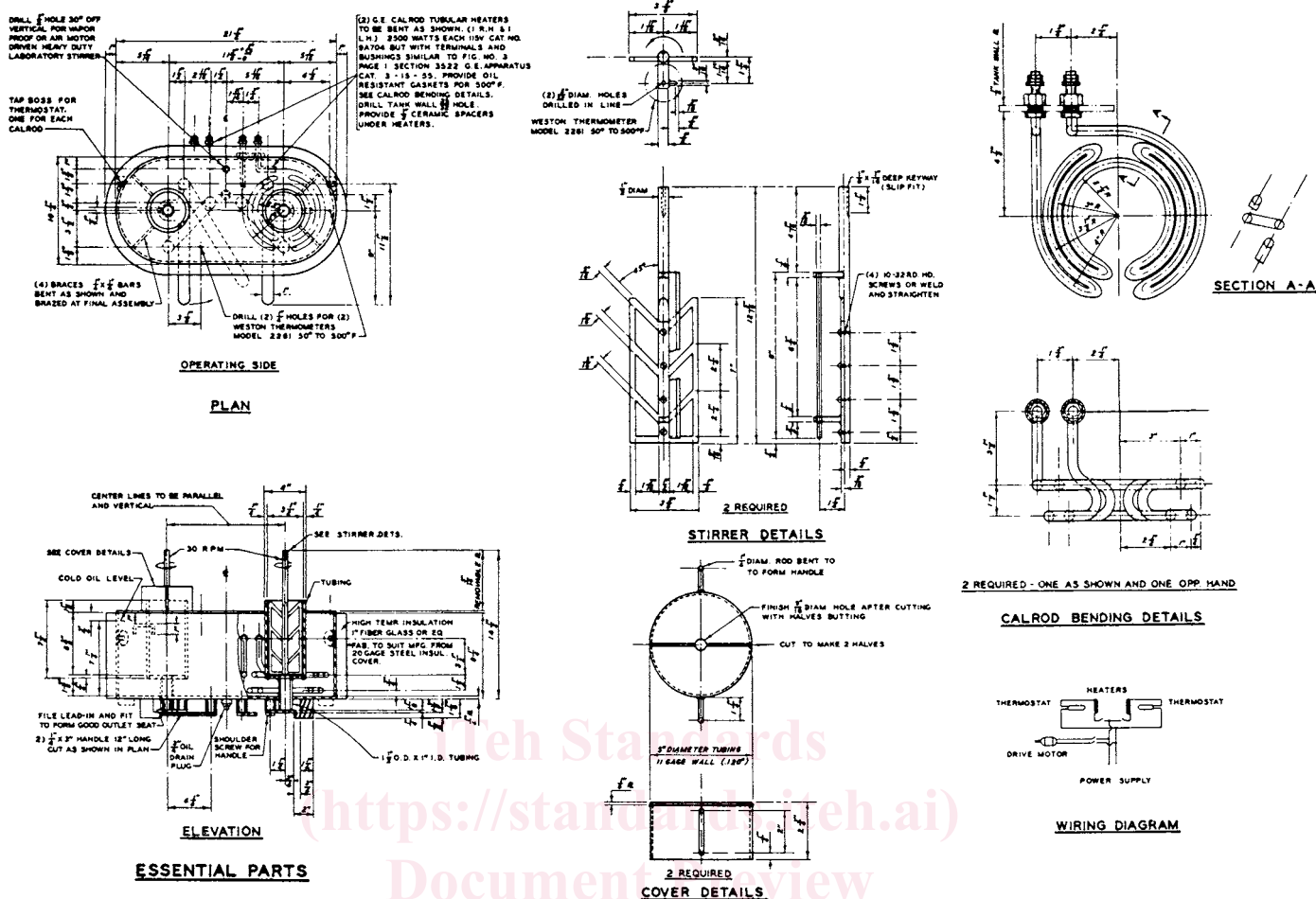

FIG. 2 Detailed Drawing of Joint Sealant Laboratory Melting Unit

a liquid in glass thermometer, such as the 2F or 2C thermometers conforming to Specification E1 or temperature measuring devices such as platinum resistance thermometers that provide equivalent or better accuracy and precision, as the reference thermometer with the Thermocouples in Stirred Liquid Baths procedure. The reference thermometer shall be NIST—certified or NIST—traceable.

NOTE 1—The removable can type melter as shown in Fig. 3 is very similar in design to the melter shown in Fig. 1 and Fig. 2. Fig. 3's pots are designed to be removed so the melted material can be poured. Extra care must be taken when using this type of melter. Check the manufacturer's recommended safety procedures before use.

7. Precautions

7.1 Prior to beginning sampling and heating of sealants or fillers, a Material Safety Data Sheet must be obtained from the sealant or filler manufacturer so that proper safe handling techniques will be used.

7.2 *Maximum Heating Temperature*—It is imperative that the manufacturer's maximum heating temperatures be obtained for the material to be evaluated. The temperature of the material must not exceed the maximum heating temperature.

7.3 The laboratory melter unit should be located under an exhaust hood to disperse fumes.

7.4 Joint/crack sealants and fillers are manufactured from a variety of materials. To avoid compatibility problems, clean the melter so that it is free of all cleaning solvents and previously melted material.

8. Procedure

8.1 Sample Preparation:

8.1.1 Obtain the sample which is delivered to the laboratory for testing in accordance with its respective standard material specification.

8.1.2 *Solid Materials*—For sealants or fillers which are solid at $23 \pm 2^\circ\text{C}$ ($73.4 \pm 3.6^\circ\text{F}$), cut a complete vertical section from the material block as illustrated in Fig. 4, in order to obtain a uniform representative sample and supply enough product to pour all specimens. Also, if present, remove container liner by cutting it away. Consult the respective material specification for the required sample size and method of cutting. Cut the entire vertical section into segments of approximately 50 g and place all segments from one vertical section in the same pot and melt.

8.1.3 *Liquid Materials*—For sealants which are liquid at $23 \pm 2^\circ\text{C}$ ($73.4 \pm 3.6^\circ\text{F}$), stir the sealant to be sampled thoroughly by hand or mechanically using a suitable stirrer until