

FINAL
DRAFT

INTERNATIONAL
STANDARD

ISO/FDIS
21395-2

ISO/TC 172/SC 3

Secretariat: JISC

Voting begins on:
2021-11-18

Voting terminates on:
2022-01-13

Optics and photonics — Test method for refractive index of optical glasses —

Part 2: V-block refractometer method

iTeh STANDARD PREVIEW
*Optique et photonique — Méthode d'essai pour l'indice de réfraction
des verres optiques —
(standards.iteh.ai)
Partie 2: Méthode du réfractomètre à blocs en V*

[ISO/FDIS 21395-2](https://standards.iteh.ai/catalog/standards/sist/433c6f13-12b1-484b-91a8-86759b03dea5/iso-fdis-21395-2)

<https://standards.iteh.ai/catalog/standards/sist/433c6f13-12b1-484b-91a8-86759b03dea5/iso-fdis-21395-2>

RECIPIENTS OF THIS DRAFT ARE INVITED TO SUBMIT, WITH THEIR COMMENTS, NOTIFICATION OF ANY RELEVANT PATENT RIGHTS OF WHICH THEY ARE AWARE AND TO PROVIDE SUPPORTING DOCUMENTATION.

IN ADDITION TO THEIR EVALUATION AS BEING ACCEPTABLE FOR INDUSTRIAL, TECHNOLOGICAL, COMMERCIAL AND USER PURPOSES, DRAFT INTERNATIONAL STANDARDS MAY ON OCCASION HAVE TO BE CONSIDERED IN THE LIGHT OF THEIR POTENTIAL TO BECOME STANDARDS TO WHICH REFERENCE MAY BE MADE IN NATIONAL REGULATIONS.



Reference number
ISO/FDIS 21395-2:2021(E)

© ISO 2021

iTeh STANDARD PREVIEW (standards.iteh.ai)

ISO/FDIS 21395-2

<https://standards.iteh.ai/catalog/standards/sist/433c6f13-12b1-484b-91a8-86759b03dea5/iso-fdis-21395-2>



COPYRIGHT PROTECTED DOCUMENT

© ISO 2021

All rights reserved. Unless otherwise specified, or required in the context of its implementation, no part of this publication may be reproduced or utilized otherwise in any form or by any means, electronic or mechanical, including photocopying, or posting on the internet or an intranet, without prior written permission. Permission can be requested from either ISO at the address below or ISO's member body in the country of the requester.

ISO copyright office
CP 401 • Ch. de Blandonnet 8
CH-1214 Vernier, Geneva
Phone: +41 22 749 01 11
Email: copyright@iso.org
Website: www.iso.org

Published in Switzerland

Contents

Page

Foreword	iv
Introduction	v
1 Scope	1
2 Normative references	1
3 Terms and definitions	1
4 Principles	2
5 Measuring equipment	3
5.1 General.....	3
5.2 Light source.....	4
5.3 Bandpass filter.....	5
5.4 Slit.....	5
5.5 Collimator lens.....	5
5.6 V-block prism.....	5
5.7 Origin-point reference block.....	6
5.8 Telescope.....	6
5.9 Detector.....	7
5.10 Deviation-angle measuring device.....	7
5.11 Refractive index matching liquid.....	7
6 Shapes of origin-point reference block and specimen	7
6.1 General.....	7
6.2 Apex angle.....	7
6.3 Contact face with V-block prism.....	7
7 Measurement method	8
7.1 Measurement environment.....	8
7.1.1 Temperature.....	8
7.1.2 Atmospheric pressure.....	8
7.2 Measurement.....	8
7.2.1 General.....	8
7.2.2 Preparation for measurement.....	8
7.2.3 Setting of deviation-angle origin point (0°).....	8
7.2.4 Adjustment of V-block prism.....	9
7.2.5 Measurement of deviation angle.....	9
7.2.6 Calculation of refractive index.....	10
8 Indication	10
9 Test report	10
Annex A (normative) Refractive index matching liquid	12
Annex B (informative) Telescope with autocollimation function	14
Annex C (normative) Alternative measurement	15
Annex D (normative) Measurement with reference specimen	24
Bibliography	26

Foreword

ISO (the International Organization for Standardization) is a worldwide federation of national standards bodies (ISO member bodies). The work of preparing International Standards is normally carried out through ISO technical committees. Each member body interested in a subject for which a technical committee has been established has the right to be represented on that committee. International organizations, governmental and non-governmental, in liaison with ISO, also take part in the work. ISO collaborates closely with the International Electrotechnical Commission (IEC) on all matters of electrotechnical standardization.

The procedures used to develop this document and those intended for its further maintenance are described in the ISO/IEC Directives, Part 1. In particular, the different approval criteria needed for the different types of ISO documents should be noted. This document was drafted in accordance with the editorial rules of the ISO/IEC Directives, Part 2 (see www.iso.org/directives).

Attention is drawn to the possibility that some of the elements of this document may be the subject of patent rights. ISO shall not be held responsible for identifying any or all such patent rights. Details of any patent rights identified during the development of the document will be in the Introduction and/or on the ISO list of patent declarations received (see www.iso.org/patents).

Any trade name used in this document is information given for the convenience of users and does not constitute an endorsement.

For an explanation of the voluntary nature of standards, the meaning of ISO specific terms and expressions related to conformity assessment, as well as information about ISO's adherence to the World Trade Organization (WTO) principles in the Technical Barriers to Trade (TBT), see www.iso.org/iso/foreword.html.

This document was prepared by Technical Committee ISO/TC 172, *Optics and photonics*, Subcommittee SC 3, *Optical materials and components*.

A list of all parts in the ISO 21395 series can be found on the ISO website.

Any feedback or questions on this document should be directed to the user's national standards body. A complete listing of these bodies can be found at www.iso.org/members.html.

Introduction

This document specifies the method to determine the refractive index of optical glasses with the V-block refractometer. Some explanation of the V-block refractometer can be found in Reference [3]. The refractive index of optical glasses is the most important characteristic for the optical elements manufactured from them.

Regarding the standardization of the method of refractive index measuring method of optical glasses, the minimum deviation method is defined as ISO 21395-1.

The minimum deviation method is most accurate in refractive index measurement but requires an advanced technical skill to prepare a specimen with a precise shape and to measure the refractive index.

In contrast the V-block refractometer method is easier and faster when preparing a specimen and requires less technical skill for measurement. Therefore, this method is commonly used by people checking the quality of the optical glass products on a daily basis.

This document is intended to aid in measuring the refractive index of optical glasses accurately and improving the communications between raw optical glass suppliers and optical element manufacturers as well.

iTeh STANDARD PREVIEW (standards.iteh.ai)

[ISO/FDIS 21395-2](https://standards.iteh.ai/catalog/standards/sist/433c6f13-12b1-484b-91a8-86759b03dea5/iso-fdis-21395-2)

<https://standards.iteh.ai/catalog/standards/sist/433c6f13-12b1-484b-91a8-86759b03dea5/iso-fdis-21395-2>

iTeh STANDARD PREVIEW
(standards.iteh.ai)

ISO/FDIS 21395-2

<https://standards.iteh.ai/catalog/standards/sist/433c6f13-12b1-484b-91a8-86759b03dea5/iso-fdis-21395-2>

Optics and photonics — Test method for refractive index of optical glasses —

Part 2: V-block refractometer method

1 Scope

This document specifies a method to determine the refractive index of optical glass with the accuracy within 3×10^{-5} at the wavelength range from 365 nm to 2 400 nm by using the V-block refractometer method.

While this document can be used for non-glass materials, the user is informed that only optical glass has been considered in the development of this document, and other materials can have issues, which have not been taken into consideration.

2 Normative references

The following documents are referred to in the text in such a way that some or all of their content constitutes requirements of this document. For dated references, only the edition cited applies. For undated references, the latest edition of the referenced document (including any amendments) applies.

ISO 280, *Essential oils — Determination of refractive index*

ISO 9802, *Raw optical glass — Vocabulary*
<https://standards.iteh.ai/catalog/standards/sist/433c6f13-12b1-484b-91a8-86759003dea5/iso-fdis-21395-2>

ISO 21395-1, *Optics and photonics — Test method for refractive index of optical glasses — Part 1: Minimum deviation method*

ISO 80000-1, *Quantities and units — Part 1: General*

ISO 80000-3, *Quantities and units — Part 3: Space and time*

3 Terms and definitions

For the purposes of this document, the terms and definitions given in ISO 9802, ISO 80000-1, ISO 80000-3 and the following apply.

ISO and IEC maintain terminological databases for use in standardization at the following addresses:

- ISO Online browsing platform: available at <https://www.iso.org/obp>
- IEC Electropedia: available at <https://www.electropedia.org/>

3.1

V-block prism

prism manufactured from optical glass material with a known refractive index

3.2

refractive index matching liquid

transparent liquid having the refractive index close to that of the specimen

4 Principles

As shown in [Figure 1a](#)), when a beam aligned perpendicular to the entrance face transmits through the V-block prism, it is refracted at the interface between the V-block prism and the specimen and exits from the exit face nominally parallel to the entrance face. The relationship among the deviation angle of the emergent beam to the incident beam, γ , the relative refractive index of the V-block prism to the measurement atmosphere, N , and the relative refractive index of the specimen to the measurement atmosphere, n , is expressed by the following [Formula \(1\)](#):

$$\gamma = \arcsin \frac{\sqrt{2 \times n^2 - N^2} - \sqrt{3 \times N^2 - 2 \times n^2}}{2} \quad (1)$$

where

- n is the relative refractive index of the specimen to the measurement atmosphere;
- N is the relative refractive index of the V-block prism to the measurement atmosphere;
- γ is the deviation angle.

NOTE In general, the symbol of the refractive index is the lowercase n . However, this document intentionally uses the capital letter N for the relative refractive index of the V-block prism to make it more distinct from that of the specimen.

The sign of the deviation angle of the emergent beam shall be positive (+) for upward deviation (that is, $n > N$) and negative (-) for downward deviation ($n < N$) respectively, relative to the incident beam.

Therefore, by measuring γ , n can be obtained by calculation.

This principle is also applicable when the incident beam angle is controlled so that the emergent beam is perpendicular to the exit face of the V block prism. Therefore, as shown in [Figure 1b](#)), it is also possible to calculate the refractive index based on the measurement result of the deviation angle of the incident beam to the emergent beam.

[7.2.6](#) provides the formula for the calculation of n .

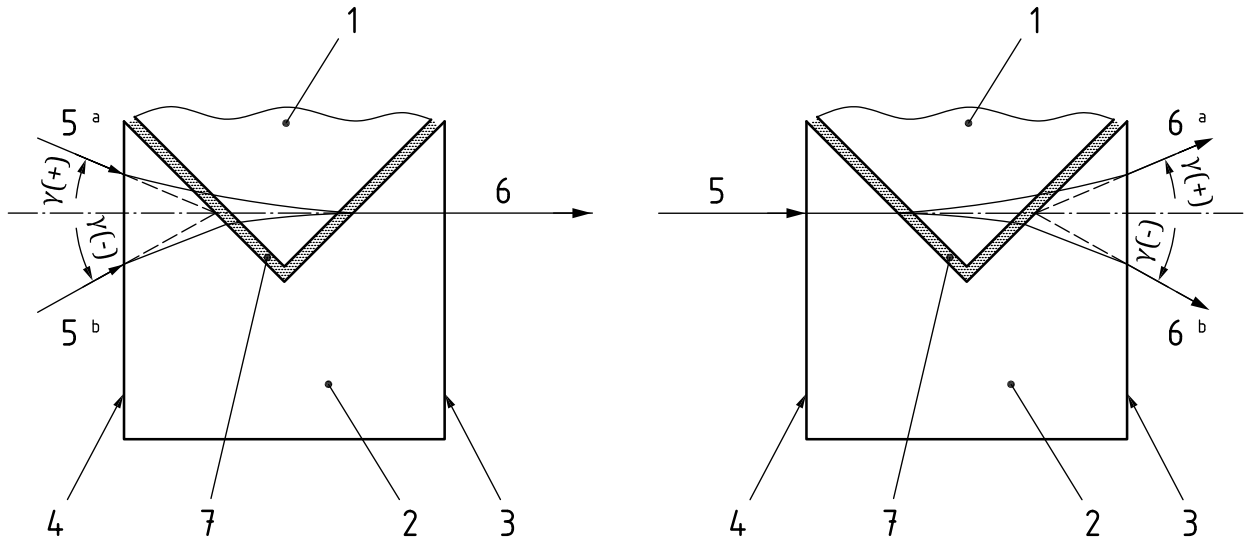

a) Deviation angle measurement on exit side

b) Deviation angle measurement on entrance side

Key

- | | | | |
|---|--|------------|----------------------------------|
| 1 | specimen (with relative refractive index, n) | 6 | emergent beam |
| 2 | V-block prism (with relative refractive index, N) | 7 | refractive index matching liquid |
| 3 | exit face | γ | deviation angle |
| 4 | entrance face | γ^a | $n > N$ |
| 5 | incident beam | γ^b | $n < N$ |

iTeh STANDARD PREVIEW
(standards.iteh.ai)

ISO/FDIS 21395-2
Figure 1 — Principle of V-block method
<https://standards.iteh.ai/catalog/standards/sis/453con5-1261-4646-91a8-86759b03dea5/iso-fdis-21395-2>

In order for [Formula \(1\)](#) to satisfy the required tolerance indicated in [Clause 1](#) (i.e., within 3×10^{-5}), the shape of the V-block prism and the specimen shall be manufactured following to [5.6](#) and [6.1](#), respectively.

5 Measuring equipment

5.1 General

The measuring equipment is composed of the elements and instruments shown in [Figure 2](#).

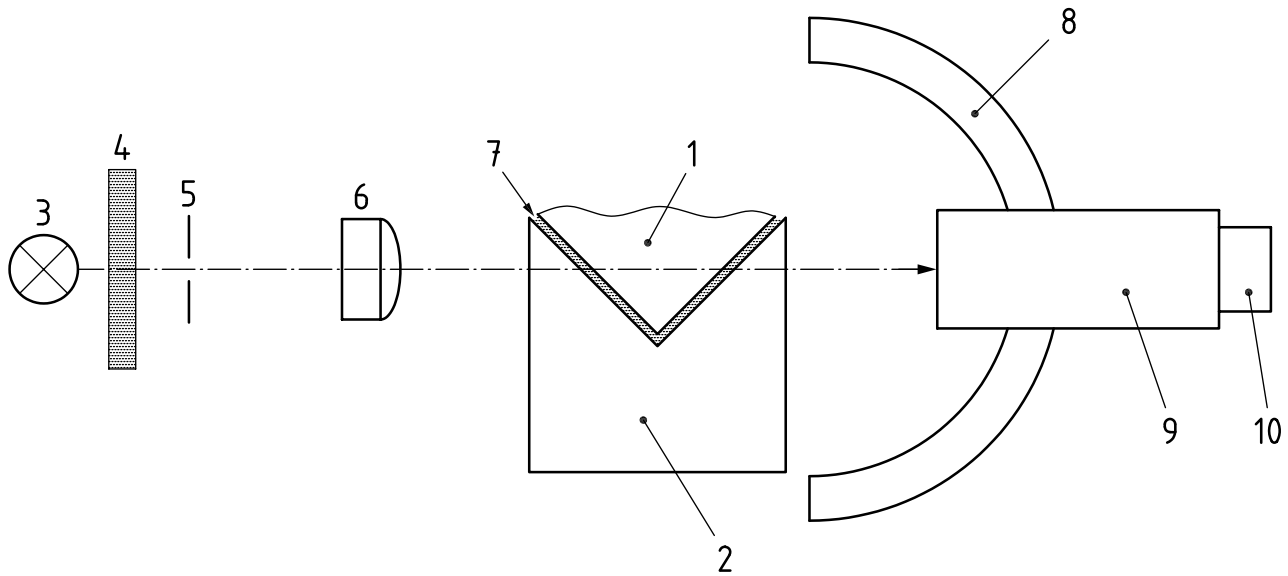

- Key**
- 1 specimen or origin point reference block
 - 2 V-block prism
 - 3 light source
 - 4 bandpass filter
 - 5 slit
 - 6 collimator lens
 - 7 refractive index matching liquid
 - 8 deviation-angle measurement device (scale plate)
 - 9 telescope
 - 10 detector (or human eye)

Figure 2 — Outline of V-block measurement equipment

Figure 2 illustrates the configuration in which the direction of the incident beam is fixed as shown in Figure 1a). When measuring the deviation angle in the case of Figure 1b), the deviation-angle measurement device (Key 8) shall be attached not to the telescope but to the light source.

The details of the components are described in 5.2 to 5.10.

5.2 Light source

The sources of the spectral/optical radiation should be discharge lamps of mercury, hydrogen, helium, rubidium, caesium or cadmium, or the He-Ne or Nd:YAG laser specified in ISO 7944^[5]. The spectral lines shown in Table 1 as the measurement wavelength are used with the bandpass filter of respective wavelength(s). It is necessary to select the light source considering the light transmittance of the V-block prism and the specimen.

It is permissible to use a light source having a wavelength different from those specified in Table 1, or a light source combining a continuous spectral light source and a monochromator/bandpass filter. However, the wavelength deviation due to the finite bandwidth shall be considered when using alternative light sources.

Table 1 — Wavelength and spectral light source

Wavelength nm	Spectral line	Light source
365,01	i	Mercury discharge tube
404,66	h	Mercury discharge tube
435,83	g	Mercury discharge tube
479,99	F'	Cadmium discharge tube

Table 1 (continued)

Wavelength nm	Spectral line	Light source
486,13	F	Hydrogen discharge tube
543,5	-	He-Ne laser
546,07	e	Mercury discharge tube
587,56	d	Helium discharge tube
632,8	-	He-Ne laser
643,85	C'	Cadmium discharge tube
656,27	C	Hydrogen discharge tube
706,52	r	Helium discharge tube
780,00	-	Rubidium discharge tube
852,11	s	Caesium discharge tube
1 013,98	t	Mercury discharge tube
1 064,1	-	Nd:YAG laser
1 128,66	-	Mercury discharge tube
1 395,1	-	Mercury discharge tube
1 529,6	-	Mercury discharge tube
1 813,1	-	Mercury discharge tube

iTeH STANDARD PREVIEW
(standards.iteh.ai)

5.3 Bandpass filter

The bandpass filter transmits only the desired wavelength of light by blocking the light of unnecessary wavelengths.

[ISO/FDIS 21395-2](#)

<https://standards.iteh.ai/catalog/standards/sist/433c6f13-12b1-484b-91a8-86759b03dea5/iso-fdis-21395-2>

5.4 Slit

The slit adjusts the width of the incident beam.

5.5 Collimator lens

The collimator lens changes the divergent beam into a parallel beam.

5.6 V-block prism

The function of the V-block prism on which the specimen is placed is to keep the deviation angle, γ , of the emergent beam relative to the incident beam within a measurable range. The V-block prism shall be manufactured from a glass where the refractive index is known with an accuracy of at least $1,0 \times 10^{-5}$ according to the measurement method of ISO 21395-1. The refractive index of the V-block prism shall be selected so that the deviation angle due to the refractive index difference between the V-block prism and a specimen falls within the range of $\pm 45^\circ$. The shape of the V-block prism is shown in [Figure 3](#).

NOTE In order to guarantee a refractive index value with $1,0 \times 10^{-5}$ units, the measured refractive index requires a value of 6 digits or more after the decimal point.

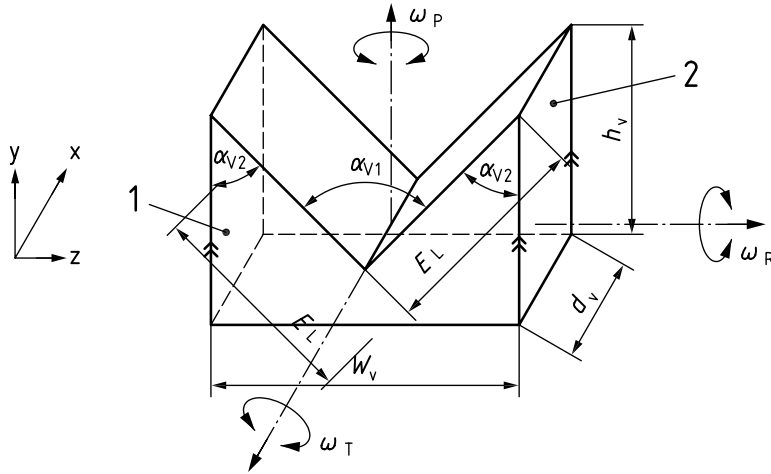

Key

1	entrance face	h_V	height
2	exit face	w_V	width
α_{V1}	angle of V-shaped faces	ω_R	roll angle
α_{V2}	angle between V-shaped face and entrance or exit face	ω_T	tilt angle
E_L	lateral edge	ω_P	pan angle
d_V	thickness		

iTeh STANDARD PREVIEW
Figure 3 — V-block prism
 (standards.iteh.ai)

The required accuracies of the V-block prism are as follows:

- a) The angle α_{V1} of V-shaped faces shall be within $90^\circ \pm 5''$. The angles α_{V2} between V-shaped face and entrance or exit face shall be $45^\circ \pm 5''$;
- b) The degree of parallelism between the entrance face and the exit face shall be within $\pm 5''$;
- c) The entrance face, exit face and V-shaped surface shall be polished with the flatness approximately $\lambda/2$ at the measurement wavelength λ ;
- d) The roll angle ω_R concerning the incident beam optical axis on the V-shaped surface shall be within $\pm 20''$.

If it is difficult to obtain such a fine-shaped V-block prism, a method shown in [Annex C](#) can be used, but in that case the calculation of the refractive index of the specimen is more complicated.

5.7 Origin-point reference block

The origin-point reference block is used for setting the deviation-angle reference point (0°) by placing it on the V-shaped face of the V-block prism. The origin-point reference block and the V-block prism shall be manufactured from the same glass lump, and the difference in refractive index between the two shall be within 5×10^{-6} . The shape of the origin point reference block is specified in [6](#).

5.8 Telescope

The telescope captures the emergent beam from the exit surface of the V-block prism and forms an image of the light at the measurement wavelength on the detector. It can be rotated around a rotation axis close to the V-block prism.

It can include an auto-collimation function. [Annex B](#) explains the composition of a telescope with an auto-collimation function.