



SLOVENSKI STANDARD

oSIST prEN 12662-1:2023

01-januar-2023

Tekoči naftni proizvodi - Določevanje vseh nečistoč - 1. del: Srednji destilati in dizelsko gorivo

Liquid petroleum products - Determination of total contamination - Part 1: Middle distillates and diesel fuels

Flüssige Mineralölerzeugnisse - Bestimmung der Gesamtverschmutzung in Mitteldestillaten, Dieselkraftstoff und Fettsäure-Methylestern

Produits pétroliers liquides - Détermination de la contamination totale des distillats moyens, des gazoles et des esters méthyliques d'acides gras

Ta slovenski standard je istoveten z: prEN 12662-1

ICS:

75.160.20 Tekoča goriva Liquid fuels

oSIST prEN 12662-1:2023 **en**

EUROPEAN STANDARD
NORME EUROPÉENNE
EUROPÄISCHE NORM

DRAFT
prEN 12662-1

January 2023

ICS

Will supersede EN 12662:2014

English Version

Liquid petroleum products - Determination of total contamination - Part 1: Middle distillates and diesel fuels

Produits pétroliers liquides - Détermination de la contamination totale - Partie 1 : Distillats moyens et gazoles

Flüssige Mineralölerzeugnisse - Bestimmung der Verschmutzung - Teil 1: Mitteldestillate und Dieselkraftstoffe

This draft European Standard is submitted to CEN members for enquiry. It has been drawn up by the Technical Committee CEN/TC 19.

If this draft becomes a European Standard, CEN members are bound to comply with the CEN/CENELEC Internal Regulations which stipulate the conditions for giving this European Standard the status of a national standard without any alteration.

This draft European Standard was established by CEN in three official versions (English, French, German). A version in any other language made by translation under the responsibility of a CEN member into its own language and notified to the CEN-CENELEC Management Centre has the same status as the official versions.

CEN members are the national standards bodies of Austria, Belgium, Bulgaria, Croatia, Cyprus, Czech Republic, Denmark, Estonia, Finland, France, Germany, Greece, Hungary, Iceland, Ireland, Italy, Latvia, Lithuania, Luxembourg, Malta, Netherlands, Norway, Poland, Portugal, Republic of North Macedonia, Romania, Serbia, Slovakia, Slovenia, Spain, Sweden, Switzerland, Türkiye and United Kingdom.

Recipients of this draft are invited to submit, with their comments, notification of any relevant patent rights of which they are aware and to provide supporting documentation.

Warning : This document is not a European Standard. It is distributed for review and comments. It is subject to change without notice and shall not be referred to as a European Standard.



EUROPEAN COMMITTEE FOR STANDARDIZATION
COMITÉ EUROPÉEN DE NORMALISATION
EUROPÄISCHES KOMITEE FÜR NORMUNG

CEN-CENELEC Management Centre: Rue de la Science 23, B-1040 Brussels

Contents	Page
European foreword	3
Introduction	4
1 Scope.....	5
2 Normative references.....	5
3 Terms and definitions.....	5
4 Principle	6
5 Reagents and materials	6
6 Equipment	6
7 Cleansing of sample containers and filtration apparatus	7
8 Sampling.....	8
9 Preparation of the test portion	8
9.1 General.....	8
9.2 Middle distillates and diesel fuels	9
9.3 Liquid petroleum products with a kinematic viscosity exceeding 8 mm ² /s at 20 °C, or 5 mm ² /s at 40 °C	9
10 Preparation of the equipment.....	9
10.1 Preparation of the filtration apparatus.....	9
10.2 Preparation of the filter.....	10
11 Procedure	10
12 Calculation.....	11
13 Expression of results	11
14 Precision	11
14.1 General.....	11
14.2 Repeatability	11
14.3 Reproducibility.....	12
15 Test report.....	12
Bibliography	13

European foreword

This document (prEN 12662-1:2023) has been prepared by Technical Committee CEN/TC 19 “Gaseous and liquid fuels, lubricants and related products of petroleum, synthetic and biological origin”, the secretariat of which is held by NEN.

This document is currently submitted to the CEN Enquiry.

This document will supersede EN 12662:2014.

In comparison with the previous edition, the following technical modifications have been made:

- split of the scope of the previous edition in two parts, with Part 1 covering the middle distillates and the diesel fuels containing up to 30 % (V/V) of fatty acid methyl ester (FAME) in this document and with Part 2 covering the neat FAME in a separated document;
- update of the precision data following a new statistical analysis [4] of the interlaboratory tests data available without the FAME samples according to EN ISO 4259-1 [1].

iTeh STANDARD PREVIEW
(standards.iteh.ai)

[oSIST prEN 12662-1:2023](https://standards.iteh.ai/catalog/standards/sist/38caf1b3-62b0-4652-996a-b3811ec51d2d/osist-pren-12662-1-2023)

<https://standards.iteh.ai/catalog/standards/sist/38caf1b3-62b0-4652-996a-b3811ec51d2d/osist-pren-12662-1-2023>

Introduction

Excessive contamination in a fuel system can give rise to premature blocking of filters and/or hardware failure, and is therefore undesirable. The determination of the content of undissolved substances, referred to as total contamination, is a way to control this issue.

In the previous version of this method, the scope was covering middle distillates, diesel fuels containing up to 30 % (V/V) of FAME and neat FAME. But, it was found that the method was not applicable for neat FAME. It has been decided to split the scope in two parts: to include the previous version as Part 1 and to develop a separate standard for neat FAME as Part 2.

iTeh STANDARD PREVIEW
(standards.iteh.ai)

[oSIST prEN 12662-1:2023](https://standards.iteh.ai/catalog/standards/sist/38caf1b3-62b0-4652-996a-b3811ec51d2d/osist-pren-12662-1-2023)

<https://standards.iteh.ai/catalog/standards/sist/38caf1b3-62b0-4652-996a-b3811ec51d2d/osist-pren-12662-1-2023>

1 Scope

This document specifies a method for the determination of the content of undissolved substances, referred to as total contamination, in middle distillates, in diesel fuels containing up to 30 % (V/V) fatty acid methyl esters (FAME). The working range is from 12 mg/kg to 26 mg/kg and it was established in an interlaboratory study by applying EN ISO 4259-1 [1].

This document in general applies to products having a kinematic viscosity not exceeding 8 mm²/s at 20 °C, or 5 mm²/s at 40 °C, e.g. diesel fuel as specified in EN 590 [2].

This test method may be used for diesel fuels containing more than 30 % (V/V) FAME and for petroleum products having a kinematic viscosity exceeding 8 mm²/s at 20 °C, or 5 mm²/s at 40 °C, however in such cases the precision of the test method has not been defined.

NOTE For the purposes of this document, the term “% (V/V)” is used to represent the volume fraction, φ , of a material.

WARNING — Use of this test method may involve hazardous materials, operations and equipment. This method does not purport to address all of the safety problems associated with its use. It is the responsibility of the user of this method to establish appropriate safety and health practices and to determine the applicability of regulatory limitations prior to use.

2 Normative references

The following documents are referred to in the text in such a way that some or all of their content constitutes requirements of this document. For dated references, only the edition cited applies. For undated references, the latest edition of the referenced document (including any amendments) applies.

EN 14275, *Automotive fuels — Assessment of petrol and diesel fuel quality — Sampling from retail site pumps and commercial site fuel dispensers* prEN 12662-1:2023

<https://standards.iteh.ai/catalog/standards/sist/38caf1b3-62b0-4652-996a->
EN ISO 3170, *Petroleum liquids — Manual sampling (ISO 3170)* -2023

EN ISO 3171, *Petroleum liquids — Automatic pipeline sampling (ISO 3171)*

ISO 3819, *Laboratory glassware — Beakers*

3 Terms and definitions

For the purposes of this document, the following terms and definitions apply.

ISO and IEC maintain terminological databases for use in standardization at the following addresses:

- IEC Electropedia: available at <https://www.electropedia.org/>
- ISO Online browsing platform: available at <https://www.iso.org/obp/ui>

3.1

total contamination

undissolved substances retained on a filter after filtration under test conditions

3.2

absolute pressure

pressure measured relative to zero pressure or a total vacuum

prEN 12662-1:2023 (E)**4 Principle**

A sample portion is weighed and filtered under vacuum through a pre-weighed filter. In the case of liquid petroleum products having a kinematic viscosity exceeding $8 \text{ mm}^2/\text{s}$ at $20 \text{ }^\circ\text{C}$, or $5 \text{ mm}^2/\text{s}$ at $40 \text{ }^\circ\text{C}$, the weighed sample portion is diluted with a solvent before filtration. The filter with the residue is washed, dried and weighed. Contamination is calculated from the difference in mass of the filter and expressed relative to the sample mass as mg/kg.

5 Reagents and materials

5.1 Heptane, with a purity no less than 99,0 % (V/V), filtered using a membrane filter (6.18).

NOTE Heptane used as a reference fuel in EN ISO 5164 [3] is suitable.

5.2 Propan-2-ol, with a purity no less than 99,0 % (V/V).

NOTE Propan-2-ol is used to dry glassware and the sample container after rinsing with water.

6 Equipment

All glassware and sample containers shall be carefully cleaned as described in Clause 7.

Usual laboratory apparatus and glassware, together with the following:

6.1 Filtration apparatus, suitable for a filter (6.2), as shown in Figure 1.

A different filtration apparatus may be used if it is suitable to take the filters given in 6.2.

6.2 Filters, of high retention glass fibre type, 47 mm in diameter and with a $0,7 \text{ }\mu\text{m}$ mean pore size.

NOTE Glass fibre filters Whatman GF-F type have been found suitable for total contamination measurements. This information is given for the convenience of users of this document and does not constitute an endorsement by CEN of this product.

6.3 Beakers, tall form 0,5 l and 1 l, conforming with ISO 3819 or an equivalent national standard.

6.4 Cylinders, 500 ml and 1 000 ml graduated cylinders.

6.5 Glass bottles, 0,5 l and 1 l, with screw caps.

6.6 Oven, of the static type (without fan assisted circulation), explosion-proof, capable of heating to $(110 \pm 5) \text{ }^\circ\text{C}$.

6.7 Desiccator, containing freshly activated silica gel (or equivalent desiccant) with a moisture content indicator.

6.8 Glass Petri dishes with covers, greater than 50 mm in diameter.

6.9 Analytical balance, capable of weighing to the nearest 0,1 mg.

6.10 Forceps, with round shaped tips for transferring the filter from the filter holder to the Petri dish and from the latter on to the dish of the analytical balance.

6.11 Water bath or oven, capable of maintaining the following temperatures: $(40 \pm 1) \text{ }^\circ\text{C}$ and $(60 \pm 1) \text{ }^\circ\text{C}$.

6.12 Wash bottle, fitted with spray nozzle, suitable for use with heptane (5.1).

6.13 Top load balance, capable of weighing 1 500 g to the nearest 0,1 g.

6.14 Vacuum source, capable of maintaining an absolute pressure of 2 kPa to 5 kPa inside the filtration apparatus (see Figure 1).

NOTE The vacuum range excludes the use of a water vacuum pump.

6.15 Suitable clean sample containers.

6.16 Stopwatch, capable of measuring 30 min \pm 1 min.

6.17 Clean plastic film or aluminium foil.

6.18 Filter, membrane with a mean pore size of 0,45 μm .

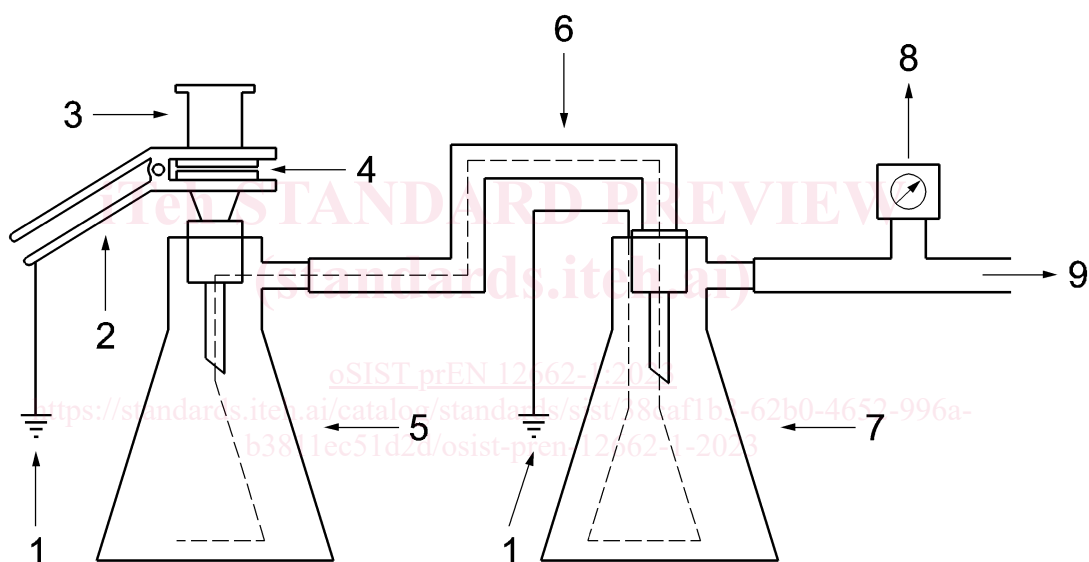

Key

1	wire to ground	4	filter holder	7	safety flask
2	clamp	5	receiving flask	8	vacuometer
3	funnel	6	vacuum tubing	9	to vacuum pump

Figure 1 — Filtration apparatus for determining contamination

7 Cleansing of sample containers and filtration apparatus

IMPORTANT — Due to the extremely low levels of material being measured, it is essential that this testing is performed in a clean environment to minimize the possibility of contamination.

7.1 Clean strictly, in the manner described in 7.2 to 7.7, all the surfaces of all components of the sample containers and parts of the apparatus that are:

a) likely to come into contact with the sample or heptane (5.1), or

prEN 12662-1:2023 (E)

b) capable of transferring extraneous matter to the filter.

7.2 Wash with warm tap water containing water soluble detergent.

7.3 Rinse thoroughly with warm tap water.

7.4 Rinse thoroughly with water, handling container caps externally only with clean laboratory tongs or gloves during this and subsequent washings.

7.5 Rinse thoroughly with propan-2-ol (5.2).

7.6 Rinse thoroughly with heptane (5.1).

7.7 Cover the top of the sample container and the funnel opening of the assembled filtration apparatus (6.1) with clean plastic film or aluminium foil (6.17) previously rinsed with heptane (5.1) and air-dried.

8 Sampling

8.1 Unless otherwise specified, obtain samples in accordance with the requirements of EN ISO 3170, EN ISO 3171, EN 14275, or an equivalent national standard.

8.2 The preferred procedure is to take samples dynamically from a sampling loop in a distribution line or from the flushing line of an automatic pipeline sampling device in accordance with the principles specified in EN ISO 3171. Ensure that the line to sampler is flushed with fuel before taking the sample.

8.3 If samples are taken manually the samples shall be taken directly into the sample container (6.15).

8.4 Where it is only possible to obtain samples from static storage follow the procedures given in EN ISO 3170, ensuring that the final sample has not passed through intermediate containers prior to placement in the prepared container.

8.5 Glass containers shall be used to take and store the samples. These containers should be cleaned according to Clause 7. Glass is used in order to facilitate the visual surveillance of the sample homogenization before subsequent analysis. Ensure that the samples receive the minimum exposure to light. Use either brown glass containers or shield the samples from light during transportation and storage. To facilitate sampling from refuelling nozzles, wide necked bottles should be used.

8.6 Fill the sample container to between 80 % and 85 % of its capacity.

8.7 The collected sample shall be homogenized according to the procedure given in 9.2.4 before any other analytical measurements are carried out, to avoid non-representative sampling when this method is performed.

9 Preparation of the test portion

9.1 General

Make sure that the sample container (6.15) is free of adhering particles which can distort the analysis. In case of doubt, rinse the outside of the container and its closure with water and propan-2-ol (5.2), as described in 7.2 to 7.5, to remove any adhering particles and avoid introducing undesirable contamination in the test sample.