

FINAL
DRAFT

INTERNATIONAL
STANDARD

ISO/FDIS
6002

ISO/TC 153

Secretariat: AFNOR

Voting begins on:
2020-10-06

Voting terminates on:
2020-12-01

Industrial valves — Bolted bonnet steel gate valves

*Robinetterie industrielle - Robinets-vannes en acier à chapeau
boulonné*

iTeh STANDARD PREVIEW
(standards.iteh.ai)

[ISO/FDIS 6002](https://standards.iteh.ai/catalog/standards/sist/9df502e7-6402-40df-99ea-e4ea66414e3e/iso-fdis-6002)

[https://standards.iteh.ai/catalog/standards/sist/9df502e7-6402-40df-99ea-
e4ea66414e3e/iso-fdis-6002](https://standards.iteh.ai/catalog/standards/sist/9df502e7-6402-40df-99ea-e4ea66414e3e/iso-fdis-6002)

RECIPIENTS OF THIS DRAFT ARE INVITED TO SUBMIT, WITH THEIR COMMENTS, NOTIFICATION OF ANY RELEVANT PATENT RIGHTS OF WHICH THEY ARE AWARE AND TO PROVIDE SUPPORTING DOCUMENTATION.

IN ADDITION TO THEIR EVALUATION AS BEING ACCEPTABLE FOR INDUSTRIAL, TECHNOLOGICAL, COMMERCIAL AND USER PURPOSES, DRAFT INTERNATIONAL STANDARDS MAY ON OCCASION HAVE TO BE CONSIDERED IN THE LIGHT OF THEIR POTENTIAL TO BECOME STANDARDS TO WHICH REFERENCE MAY BE MADE IN NATIONAL REGULATIONS.



Reference number
ISO/FDIS 6002:2020(E)

© ISO 2020

iTeh STANDARD PREVIEW
(standards.iteh.ai)

ISO/FDIS 6002

<https://standards.iteh.ai/catalog/standards/sist/9df502e7-6402-40df-99ea-e4ea66414e3e/iso-fdis-6002>



COPYRIGHT PROTECTED DOCUMENT

© ISO 2020

All rights reserved. Unless otherwise specified, or required in the context of its implementation, no part of this publication may be reproduced or utilized otherwise in any form or by any means, electronic or mechanical, including photocopying, or posting on the internet or an intranet, without prior written permission. Permission can be requested from either ISO at the address below or ISO's member body in the country of the requester.

ISO copyright office
CP 401 • Ch. de Blandonnet 8
CH-1214 Vernier, Geneva
Phone: +41 22 749 01 11
Email: copyright@iso.org
Website: www.iso.org

Published in Switzerland

Contents

	Page
Foreword	iv
1 Scope	1
2 Normative references	1
3 Terms and definitions	2
4 Pressure/temperature ratings	3
5 Design	3
5.1 Body wall thickness	3
5.2 Body dimensions	5
5.2.1 Flanges	5
5.2.2 Weld ends	6
5.3 Gate	7
5.4 Stem	8
5.5 Auxiliary connections	8
5.6 Closure test	11
5.7 Operation	11
6 Materials	12
6.1 Materials other than trim materials	12
6.2 Trim	12
7 Testing and inspection	13
8 Marking	13
8.1 Legibility	13
8.2 Body markings	14
8.3 Ring joints marking	14
8.4 Identification plate marking	14
Bibliography	15

Foreword

ISO (the International Organization for Standardization) is a worldwide federation of national standards bodies (ISO member bodies). The work of preparing International Standards is normally carried out through ISO technical committees. Each member body interested in a subject for which a technical committee has been established has the right to be represented on that committee. International organizations, governmental and non-governmental, in liaison with ISO, also take part in the work. ISO collaborates closely with the International Electrotechnical Commission (IEC) on all matters of electrotechnical standardization.

The procedures used to develop this document and those intended for its further maintenance are described in the ISO/IEC Directives, Part 1. In particular, the different approval criteria needed for the different types of ISO documents should be noted. This document was drafted in accordance with the editorial rules of the ISO/IEC Directives, Part 2 (see www.iso.org/directives).

Attention is drawn to the possibility that some of the elements of this document may be the subject of patent rights. ISO shall not be held responsible for identifying any or all such patent rights. Details of any patent rights identified during the development of the document will be in the Introduction and/or on the ISO list of patent declarations received (see www.iso.org/patents).

Any trade name used in this document is information given for the convenience of users and does not constitute an endorsement.

For an explanation of the voluntary nature of standards, the meaning of ISO specific terms and expressions related to conformity assessment, as well as information about ISO's adherence to the World Trade Organization (WTO) principles in the Technical Barriers to Trade (TBT), see www.iso.org/iso/foreword.html.

This document was prepared by Technical Committee ISO/TC 153, *Valves*.

This second edition cancels and replaces the first edition (ISO 6002:1992), which has been technically revised.

The main changes compared to the previous edition are as follows:

- in the whole text, deletion of PN 20 and PN 50, addition of PN 63 and inclusion of nominal pipe sizes NPS and Class designations;
- update of the normative references in [Clause 2](#);
- addition of definitions for DN, NPS, PN and Class;
- revision of [Figure 1](#) identifying valves terms and [Figure 6](#) for butt-welding for auxiliary connections;
- addition of requirements for gate in [5.3](#) and stem in [5.4](#);
- addition of requirements for closure test in [5.6](#);
- deletion of former [Table 1](#) on body wall thickness, deletion of former [Table 3](#) on end-to-end dimensions for butt-weld end valves and deletion of former [5.4](#) on envelope dimensions;
- revision of [Table 1](#) on body end port inside diameter, and [Table 8](#) on component materials;
- update of [Clause 7](#) on testing and inspection and [Clause 8](#) on marking.

Any feedback or questions on this document should be directed to the user's national standards body. A complete listing of these bodies can be found at www.iso.org/members.html.

Industrial valves — Bolted bonnet steel gate valves

1 Scope

This document specifies the requirements for bolted bonnet steel gate valves having the following features:

- bolted bonnet;
- outside screw and yoke;
- inside screw (alternative for PN 10, PN 16, Class 150, PN 25 and PN 40 only);
- single or double obturator;
- wedge or parallel seating;
- with or without non-metallic obturator or seat seals;
- flanged or butt-welding ends.

It covers valves of the nominal sizes DN:

- 10; 15; 20; 25; 32; 40; 50; 65; 80; 100; 125; 150; 200; 250; 300; 350; 400; 450; 500; 600; 700; 800; 900; 1 000;

corresponding to nominal pipe sizes NPS:

- $\frac{3}{8}$; $\frac{1}{2}$; $\frac{3}{4}$; 1; 1 $\frac{1}{4}$; 1 $\frac{1}{2}$; 2; 2 $\frac{1}{2}$; 3; 4; 5; 6; 8; 10; 12; 14; 16; 18; 20; 24; 28; 32; 36; 40;

and applies to valves of the following pressure designations:

- PN 10; 16; 25; 40; 63; 100;
- Class 150; 300; 600.

This document applies to bolted bonnet steel gate valves used for all industrial applications.

Additional requirements given in the relevant application standards can apply to bolted bonnet steel gate valves used for more specific applications (e.g. for the water industry, the chemical and petrochemical process industry, the oil and gas industry).

2 Normative references

The following documents are referred to in the text in such a way that some or all of their content constitutes requirements of this document. For dated references, only the edition cited applies. For undated references, the latest edition of the referenced document (including any amendments) applies.

ISO 4991, *Steel castings for pressure purposes*

ISO 5208, *Industrial valves — Pressure testing of metallic valves*

ISO 5210, *Industrial valves — Multi-turn valve actuator attachments*

ISO 5752, *Metal valves for use in flanged pipe systems — Face-to-face and centre-to-face dimensions*

ISO 9327 (all parts), *Steel forgings and rolled or forged bars for pressure purposes — Technical delivery conditions*

ISO/FDIS 6002:2020(E)

ISO 9328-1, *Steel flat products for pressure purposes — Technical delivery conditions — Part 1: General requirements*

ISO 9328-2, *Steel flat products for pressure purposes — Technical delivery conditions — Part 2: Non-alloy and alloy steels with specified elevated temperature properties*

ISO 9328-3, *Steel flat products for pressure purposes — Technical delivery conditions — Part 3: Weldable fine grain steels, normalized*

ISO 9328-4, *Steel flat products for pressure purposes — Technical delivery conditions — Part 4: Nickel-alloy steels with specified low temperature properties*

ISO 9328-5, *Steel flat products for pressure purposes — Technical delivery conditions — Part 5: Weldable fine grain steels, thermomechanically rolled*

ISO 14737, *Carbon and low alloy cast steels for general applications*

EN 1092-1, *Flanges and their joints — Circular flanges for pipes, valves, fittings and accessories, PN designated — Part 1: Steel flanges*

EN 12982, *Industrial valves — End-to-end and centre-to-end dimensions for butt welding end valves*

EN 12516-1, *Industrial valves — Shell design strength — Part 1: Tabulation method for steel valve shells*

EN 12516-2, *Industrial valves — Shell design strength — Part 2: Calculation method for steel valve shells*

ASME B16.10, *Face-to-Face and End-to-End Dimensions of Valves*

ASME B16.34, *Valves Flanged, Threaded, and Welding End*

ITEH STANDARD PREVIEW
(standards.iteh.ai)

3 Terms and definitions

ISO/FDIS 6002

<https://standards.iteh.ai/catalog/standards/sist/9df502e7-6402-40df-99ea-04ca8077423c/iso-145-6002>

For the purposes of this document, the following terms and definitions apply.

ISO and IEC maintain terminological databases for use in standardization at the following addresses:

- ISO Online browsing platform: available at <https://www.iso.org/obp>
- IEC Electropedia: available at <http://www.electropedia.org/>

3.1

nominal size

DN

NPS

alphanumeric designation of size for components of a pipework system, which is used for reference purposes, comprising the letters DN or NPS followed by a dimensionless number indirectly related to the physical size, in millimetres, of the bore or outside diameter of the end connections

Note 1 to entry: The number following the letters DN or NPS does not represent a measurable value and is not used for calculation purposes except where specified in the relevant standard.

Note 2 to entry: See ISO 6708 and ASME B16.34.

3.2 PN Class

alphanumeric designation for pressure-temperature rating that is common for components used in a piping system, used for reference purposes, comprising the letters "PN" or "Class" followed by a dimensionless number indirectly related to the pressure retaining capability as a function of temperature of the component

Note 1 to entry: The number following the letters PN or Class does not represent a measurable value and is not used for calculation purposes except where specified in the relevant standard. There is no definitive correlation that links PN designations to Class designations.

Note 2 to entry: See ISO 7268 and ASME B16.34.

4 Pressure/temperature ratings

4.1 The pressure/temperature ratings shall be in accordance with EN 12516-1 for PN-designated valves and in accordance with ASME B16.34 for Class-designated valves.

4.2 The temperature shown for a corresponding pressure rating is the temperature of the pressure-containing shell of the valve. In general, this temperature is the same as that of the contained fluid. The use of a pressure rating corresponding to a temperature other than that of the contained fluid is the responsibility of the user.

4.3 For temperatures below the lowest temperature listed in the pressure/temperature rating tables, the working pressure shall not be greater than the pressure stated for the lowest listed temperature. The use of valves at lower temperatures is the responsibility of the user. Consideration should be given to the loss of ductility and impact strength of many materials at low temperature.

<https://standards.iteh.ai/catalog/standards/sist/9df502e7-6402-40df-99ea-e4ea66414e3e/iso-fdis-6002>

5 Design

5.1 Body wall thickness

5.1.1 The terms used in [5.1](#) are illustrated in [Figure 1](#). d is the minimum inside diameter given in [Table 1](#).

5.1.2 The minimum body wall thickness, T_m , at the time of manufacture, shall be in accordance with:

- EN 12516-1 or EN 12516-2 for PN-designated valves,
- ASME B16.34 or EN 12516-1 for Class-designated valves.

Exceptions are given in [5.1.3](#) to [5.1.5](#).

Additional metal thickness needed for assembly stresses, closing stresses, stress concentrations and shapes other than circular shall be determined by the manufacturers, since these factors vary widely.

5.1.3 The weld preparation in butt-welding end valves (see [5.2.2.2](#)) shall not reduce the body wall thickness to less than the values specified in [5.1.2](#) within a region closer to the outside surface of the body neck than T_m measured along the run direction.

The transition to the weld preparation shall be gradual and the section shall be essentially circular through the entire length of the transition. Sharp discontinuities or abrupt changes in section in areas that infringe into the transition shall be avoided, except that test collars or bands, either welded or integral, are allowed.

In no case shall the thickness be less than $0,77 T_m$ at a distance of $2 T_m$ from the weld end.

5.1.4 The valve body neck shall maintain the minimum body wall thickness T_m as specified in 5.1.2 within the distance $1,1 \sqrt{dT_m}$ measured from the outside of the body run along the neck direction, where d is the inside diameter as defined in 5.2.1.3.

Beyond the distance $1,1 \sqrt{dT_m}$ from the outside of the body run, straight circular sections of body necks with inside diameter d' shall be provided with a minimum local wall thickness of T' where T' is determined, by interpolation if necessary, as the value of T_m which would correspond to a value of d equal to $2d'/3$, using the applicable nominal pressure rating.

For any case where $d' > 1,5 d$, the newly determined minimum wall thickness for the body neck will be greater than the basic value T_m . In such cases, this greater wall thickness shall be provided for all parts of the body neck having a diameter greater than $1,5 d$.

5.1.5 Local areas having less than the minimum wall thickness are acceptable provided that all of the following limitations are satisfied.

- a) The area of less than minimum thickness can be enclosed by a circle whose diameter is no greater than $0,35 \sqrt{dT_m}$.
- b) Measured thickness is no less than $0,75 T_m$
- c) Enclosure circles are separated from each other by an edge-to-edge distance of no less than $1,75 \sqrt{dT_m}$.

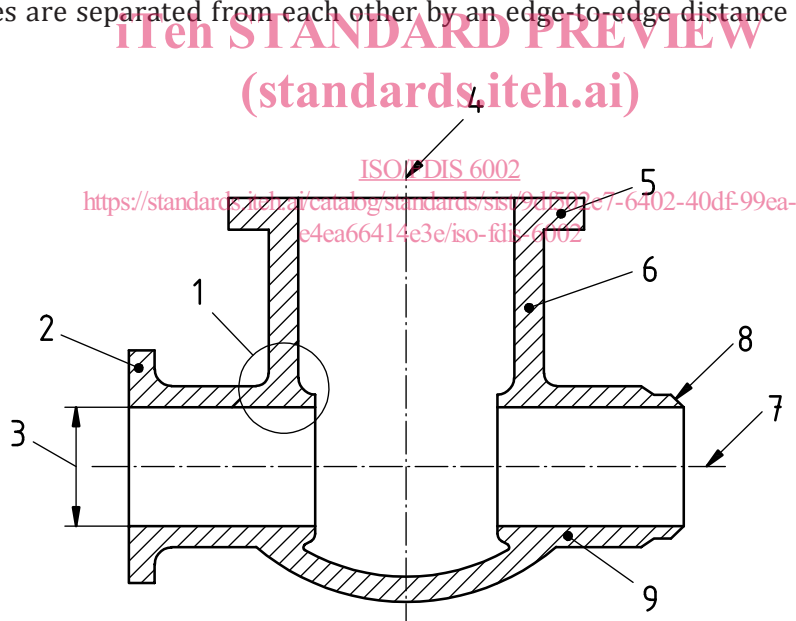

Key

- | | | | |
|---|------------------------------------|---|------------------|
| 1 | junction of body run and body neck | 6 | body neck |
| 2 | body end flange | 7 | axis of body run |
| 3 | body end port inside diameter | 8 | butt-welding end |
| 4 | axis of body neck | 9 | body run |
| 5 | body/bonnet flange | | |

Figure 1 — Identification of terms

5.2 Body dimensions

5.2.1 Flanges

5.2.1.1 Body end flanges shall comply with the requirements of ASME B16.34 for Class-designated valves and EN 1092-1 for PN-designated valves. Raised face end flanges shall be provided unless otherwise specified by the purchaser.

5.2.1.2 Face-to-face dimensions for flanged end valves shall be in accordance with ISO 5752 for the appropriate pressure designation.

5.2.1.3 End flanges shall be cast or forged integral with the body except that flanges may be attached by welding by a qualified welding operator using a qualified welding procedure, provided that all such flanges on valves DN 50 and larger are butt-welded. Any heat treatment necessary to ensure that the material is suitable for the full range of service temperatures shall be performed.

5.2.1.4 For unlined flanged valves, the minimum inside diameter, d , of the body end port shall be as specified in [Table 1](#) as applicable.

Table 1 — Body end port inside diameter d

Dimensions in mm

DN	PN 10, PN 16	PN 25, PN 40	PN 63, PN 100	Class 150	Class 300	Class 600	NPS
10	10	10	10	—	—	—	$\frac{3}{8}$
15	13	13	13	13	13	13	$\frac{1}{2}$
20	19	19	19	19	19	19	$\frac{3}{4}$
25	25	25	25	25	25	25	1
32	32	32	32	32	32	32	1 $\frac{1}{4}$
40	38	38	38	38	38	38	1 $\frac{1}{2}$
50	50	50	50	51	51	51	2
65	64	64	64	64	64	64	2 $\frac{1}{2}$
80	76	76	76	76	76	76	3
100	100	100	100	102	102	102	4
125	125	125	125	127	127	127	5
150	150	150	150	152	152	152	6
200	200	200	200	203	203	200	8
250	250	250	250	254	254	248	10
300	300	300	300	305	305	298	12
350	335	335	325	337	337	327	14
400	385	385	375	387	387	375	16
450	430	430	420	438	432	419	18
500	485	485	465	489	483	464	20
600	585	585	560	591	584	559	24
700	690	685	—	692	686	—	28
800	795	790	—	788	786	—	32
900	895	885	—	889	884	—	36
1 000	990	985	—	991	983	—	40

5.2.2 Weld ends

5.2.2.1 End-to-end dimensions for butt-weld end valves shall comply with the requirements of ASME B16.10 for Class designated valves, and EN 12982 for PN designated valves, unless otherwise specified in the purchase order.

5.2.2.2 Butt-welding ends shall be in accordance with the details shown in Figure 2, unless otherwise specified in the purchase order.

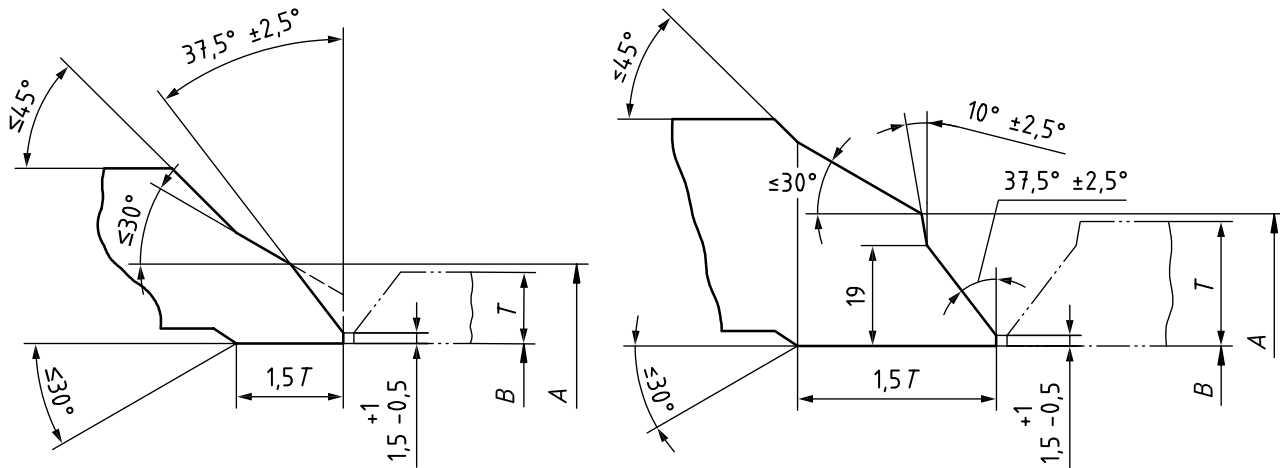

a) Welding end for connection to pipe of wall thickness $T \leq 22$ mm b) Welding end for connection to pipe of wall thickness $T > 22$ mm

Key

- A outside diameter of welding end (see Table 2)
- B inside diameter of pipe (for tolerance on B, see Table 2)
- T wall thickness of pipe

Intersections should be slightly rounded.

Valves having a minimum wall thickness $T_m \leq 3$ mm may have ends cut square or slightly chamfered.

NOTE 1 The inside and outside surfaces of valve welding ends are machine finished overall. The contour within the envelope is at the option of the manufacturer unless specifically ordered otherwise.

NOTE 2 For the outside diameters and wall thicknesses of standard steel pipes, see ISO 4200.

Figure 2 — Weld ends

Table 2 — Dimensions and tolerances of weld ends

Dimensions in mm

DN	25	32	40	50	65	80	100	125	150	200	250	300	350	400	450	500	600	700	800	900	1 000	
NPS	1	1 ¼	1 ½	2	2 ½	3	4	5	6	8	10	12	14	16	18	20	24	28	32	36	40	
A	Out-side diameter	35	44	50	62	78	91	117	144	172	223	278	329	362	413	464	516	619	721	825	927	1029
	Tol.	+2,5 -1,0						+4 -1														
B	Tol.	+1 -1					+2 -2					+3 -2										

5.3 Gate

5.3.1 Gate configurations are categorized as illustrated in [Figure 3](#).

A one-piece wedge gate—as either a solid or flexible wedge design—shall be furnished, unless otherwise specified.

A two-piece split wedge gate or parallel seat double disc gate may be furnished when specified. A split wedge gate consists of two independent seating parts that conform to the body seats when closed. A double disc gate has a spreading mechanism that forces the two parallel discs to the body seats when closed.

5.3.2 Except for a double disc gate, in the open position, the gate shall completely clear the valve seat openings.

5.3.3 Gate and gate guides shall be designed so that all parts can function properly independent of installed valve orientation.

5.3.4 Guides shall be provided in the gate and shell and these guides shall be designed to minimize seat wear and maintain gate-to-stem alignment in all valve orientations. Gate-to-shell design shall take into account the wear that may be caused by corrosion, erosion and abrasion.

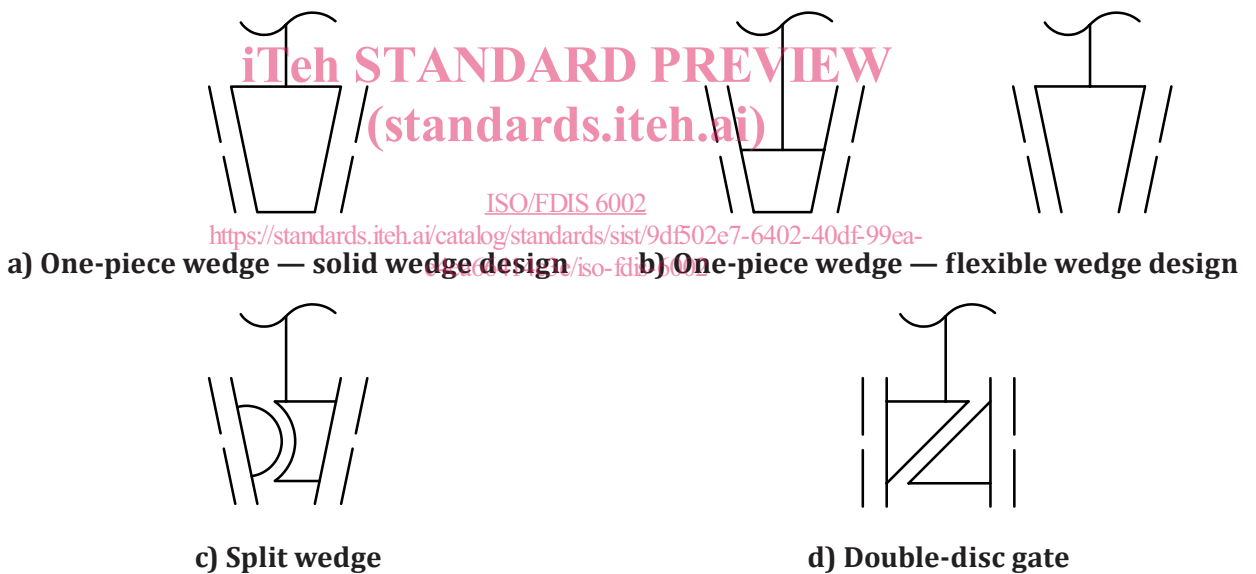

Figure 3 — Types of valve gates

5.3.5 Gate seating surfaces shall be integral or faced with weld metal. Unless specified, hardfaced seating surfaces are not required. Finished thickness of any facing material shall be not less than 1,6 mm.

5.3.6 Wedge gates shall be designed to account for seat wear. The dimensions that fix the position of the gate seats relative to the body seats shall be such that the gate, starting from the time of manufacture, can, as a result of seat wear, move into the seats by a distance, h , defined as wear travel. Wear travel is in