

---

---

## Industrial valves — Design validation- testing of valves

*Robinetterie industrielle - Essais de validation de la conception des  
appareils de robinetterie*

**iTeh STANDARD PREVIEW**  
**(standards.iteh.ai)**

[ISO 23632:2021](https://standards.iteh.ai/catalog/standards/sist/ca81c3da-26a8-48ca-8da6-42f0e3a44a34/iso-23632-2021)

<https://standards.iteh.ai/catalog/standards/sist/ca81c3da-26a8-48ca-8da6-42f0e3a44a34/iso-23632-2021>



## iTeh STANDARD PREVIEW (standards.iteh.ai)

ISO 23632:2021

<https://standards.iteh.ai/catalog/standards/sist/ca81c3da-26a8-48ca-8da6-42f0e3a44a34/iso-23632-2021>



### **COPYRIGHT PROTECTED DOCUMENT**

© ISO 2021

All rights reserved. Unless otherwise specified, or required in the context of its implementation, no part of this publication may be reproduced or utilized otherwise in any form or by any means, electronic or mechanical, including photocopying, or posting on the internet or an intranet, without prior written permission. Permission can be requested from either ISO at the address below or ISO's member body in the country of the requester.

ISO copyright office  
CP 401 • Ch. de Blandonnet 8  
CH-1214 Vernier, Geneva  
Phone: +41 22 749 01 11  
Email: [copyright@iso.org](mailto:copyright@iso.org)  
Website: [www.iso.org](http://www.iso.org)

Published in Switzerland

# Contents

	Page
<b>Foreword</b> .....	<b>iv</b>
<b>Introduction</b> .....	<b>v</b>
<b>1 Scope</b> .....	<b>1</b>
<b>2 Normative references</b> .....	<b>1</b>
<b>3 Terms and definitions</b> .....	<b>1</b>
<b>4 Type test</b> .....	<b>3</b>
4.1 Test condition.....	3
4.1.1 General.....	3
4.1.2 Closure test.....	3
4.1.3 Torque measurement.....	4
4.1.4 Temperature measurement.....	4
4.1.5 Test facility and safety rules.....	6
4.1.6 Mechanical-cycle classes.....	6
4.2 Test description.....	7
4.2.1 General.....	7
4.2.2 Test temperatures.....	7
4.2.3 Closure test.....	8
4.2.4 Unseating torque.....	8
4.2.5 Maximum allowable stem torque (MAST).....	8
4.2.6 Post-test examination.....	8
4.2.7 Qualification.....	8
4.3 Test report.....	9
<b>5 Extensions of qualification to the product range</b> .....	<b>9</b>
<b>Annex A (informative) Report template</b> .....	<b>12</b>
<b>Bibliography</b> .....	<b>14</b>

## Foreword

ISO (the International Organization for Standardization) is a worldwide federation of national standards bodies (ISO member bodies). The work of preparing International Standards is normally carried out through ISO technical committees. Each member body interested in a subject for which a technical committee has been established has the right to be represented on that committee. International organizations, governmental and non-governmental, in liaison with ISO, also take part in the work. ISO collaborates closely with the International Electrotechnical Commission (IEC) on all matters of electrotechnical standardization.

The procedures used to develop this document and those intended for its further maintenance are described in the ISO/IEC Directives, Part 1. In particular, the different approval criteria needed for the different types of ISO documents should be noted. This document was drafted in accordance with the editorial rules of the ISO/IEC Directives, Part 2 (see [www.iso.org/directives](http://www.iso.org/directives)).

Attention is drawn to the possibility that some of the elements of this document may be the subject of patent rights. ISO shall not be held responsible for identifying any or all such patent rights. Details of any patent rights identified during the development of the document will be in the Introduction and/or on the ISO list of patent declarations received (see [www.iso.org/patents](http://www.iso.org/patents)).

Any trade name used in this document is information given for the convenience of users and does not constitute an endorsement.

For an explanation of the voluntary nature of standards, the meaning of ISO specific terms and expressions related to conformity assessment, as well as information about ISO's adherence to the World Trade Organization (WTO) principles in the Technical Barriers to Trade (TBT), see [www.iso.org/iso/foreword.html](http://www.iso.org/iso/foreword.html).

This document was prepared by Technical Committee ISO/TC 153, *Valves*.

Any feedback or questions on this document should be directed to the user's national standards body. A complete listing of these bodies can be found at [www.iso.org/members.html](http://www.iso.org/members.html).

## Introduction

The scope of this document is currently limited to ball and butterfly valves.

The objective of this document is to outline the requirements and methods for evaluating the performance of metallic industrial valves with respect to seat performance and operating torque capability. Fugitive emission performance was omitted, as it is covered by ISO 15848-1. The number of cycles (205) is consistent with the number in C01 of ISO 15848-1:2015. It serves to test the accuracy and dependability of the measurements and capabilities of a valve as published by the manufacturer in the valve's technical documentation.

Type validation is the most reliable method to validate a range of valve products, covering many aspects, such as its design, material selection and manufacturing processes. It will also serve as a guide for valve selection, allowing customers to compare different valve types, designs and brands.

Several major customers already require type tests, each having their own requirements and specifications. Introducing a defined International Standard will reduce manufacturer's costs by decreasing the number of qualifications, as well as decreasing end-user total cost-of-ownership, by eliminating the possibility of unintentional design flaws.

This validation will improve performance and safety in the plants by enabling any customer to specify durable type-tested industrial valves.

## iTeh STANDARD PREVIEW (standards.iteh.ai)

ISO 23632:2021

<https://standards.iteh.ai/catalog/standards/sist/ca81c3da-26a8-48ca-8da6-42f0e3a44a34/iso-23632-2021>

**iTeh STANDARD PREVIEW**  
**(standards.iteh.ai)**

ISO 23632:2021

<https://standards.iteh.ai/catalog/standards/sist/ca81c3da-26a8-48ca-8da6-42f0e3a44a34/iso-23632-2021>

# Industrial valves — Design validation-testing of valves

## 1 Scope

This document specifies requirements and acceptance criteria for type testing, in compliance with design conditions, of metallic butterfly and ball valves used for isolating services for all industrial applications, and serves to validate the product design over 205 cycles.

This document excludes testing for safety devices, control valves, thermoplastics valves, and valves for water supply for human consumption and sewage (e.g. the EN 1074 series).

This document defines the procedure for extending the qualification of the tested valve to untested sizes and pressure designations of the same product range.

The purpose of this type test is to validate the seat performance within manufacturer given pressure/temperature rating, provided by the manufacturer's technical documentation of the product. This type test verifies torque requirements and the maximum allowable stem torque (MAST), as given in the manufacturer's technical documentation. This type test validates the durability of seat performance and operating torque through mechanical and thermal cycles.

## 2 Normative references

The following documents are referred to in the text in such a way that some or all their content constitutes requirements of this document. For dated references, only the edition cited applies. For undated references, the latest edition of the referenced document (including any amendments) applies.

ISO 5208, *Industrial valves — Pressure testing of metallic valves*

ISO 15848-1, *Industrial valves — Measurement, test and qualification procedures for fugitive emissions — Part 1: Classification system and qualification procedures for type testing of valves*

## 3 Terms and definitions

For the purposes of this document, the terms and definitions given in ISO 5208 and ISO 15848-1 and the following apply.

ISO and IEC maintain terminological databases for use in standardization at the following addresses:

- ISO Online browsing platform: available at <https://www.iso.org/obp>
- IEC Electropedia: available at <http://www.electropedia.org/>

### 3.1

#### **asymmetric sealed valve**

valve with an internal construction, which does not have a plane of symmetry perpendicular to the axis of the body ends

Note 1 to entry: This is a valve where both seat and sealing elements are not identical.

### 3.2

#### **bidirectional valve**

valve designed for blocking the flow in both downstream and upstream directions

**3.3**  
**maximum allowable stem torque**  
**MAST**

maximum torque that can be applied to a valve stem or shaft without causing permanent deformation or mechanical damage to the stem or any other components of the valve that prevent sealing or operation

**3.4**  
**minimum allowable temperature**  
minimum temperature for which the valve is designed

**3.5**  
**obturator**  
movable component of the valve whose position in the fluid flow path permits, restricts or obstructs the fluid flow

**3.6**  
**operating mechanism**  
mechanism which translates the motion of the manual- or power-operated device to the motion of the *obturator* (3.5)

**3.7**  
**post-test examination**  
disassembly, inspection and examination after completion of all the tests

**3.8**  
**qualified facility**  
independent test facility accredited and certified to perform valve type testing  
(standards.iteh.ai)

**3.9**  
**room temperature**  
**RT**  
temperature in the range of +5 °C to +40 °C

ISO 23632:2021  
<http://standards.iteh.ai/catalog/standards/sist/ca81c3da-26a8-48ca-8da6-42f0e3a44a34/iso-23632-2021>

**3.10**  
**seating torque**  
torque applied to the shaft to move the *obturator* (3.5) into contact with the seat immediately prior to the closure test

**3.11**  
**seat performance**  
closure test over a range of mechanical, pressure and temperature cycles

**3.12**  
**symmetric sealed valve**  
valve with an internal construction which has a plane of symmetry perpendicular to the axis of the body ends

Note 1 to entry: This is a valve where both seat and sealing elements are identical.

**3.13**  
**torque measurement**  
measurement of *seating* (3.10) and *unseating torques* (3.14) using calibrated measuring equipment

**3.14**  
**unseating torque**  
torque applied to open the valve against the maximum differential pressure

**3.15**  
**design validation testing**  
protocol where valves are type tested at the maximum rated pressures and design temperature ranges as specified by the manufacturer



**3.16****unidirectional valve**

valve designed for blocking the flow in either downstream or upstream direction only

**4 Type test****4.1 Test condition****4.1.1 General**

The valve manufacturer shall issue a declaration of conformity that the valve to be tested is representative of the products that are being shipped to customers and is not specially prepared for this test. The valve to be tested may be externally coated or painted.

This declaration of conformity shall state that the valve components and the assembled valve have undergone all the manufacturing, assembly and hydrostatic shell test steps of the typical quality control plan provided by the manufacturer.

The allowable seat leakage rates, according to ISO 5208, shall be specified by the valve manufacturer before the start of the type test.

The test equipment shall be appropriately selected to assure it adheres to the specific type test operating conditions. This equipment should also be in accordance with the applicable health, safety and environmental management system.

All measuring instruments shall be calibrated and shall be within their period of validity at the date of testing.

**4.1.2 Closure test**

ISO 23632:2021

<https://standards.iteh.ai/catalog/standards/sist/ca81c3da-26a8-48ca-8da6-421d2114e346/iso-23632-2021>

Pressure test for the purpose of validating leakage through a valve's closure mechanism shall be measured with dry air or other suitable gas using the mandatory closure test procedure given in ISO 5208 per the applicable product standard. Over 5 MPa (50 bars), self-ignition risks shall be considered when testing with dry air.

For a closure test performed at high or low temperature, the temperature of the exiting test gas shall be measured (before the flowmeter) and verified to be within the calibration range of the flowmeter. For volume flow measurement it is required to correct that measurement for the effect of temperature, or to bring the temperature of the exiting test gas within room temperature.

The perfect gas relationship assuming constant pressure shall be used to determine the equivalent flow rate at room temperature. See ISO 28921-1 for the detailed calculation.

$$Q_2 = \frac{Q_1 \times T_2}{T_1} \quad (1)$$

where

$T_1$  is the test gas temperature entering the flowmeter, in Kelvin (K);

$T_2$  is 298 K, the standard ambient temperature, in Kelvin (K);

$Q_1$  is the test gas flow exiting the flowmeter, in cubic millimetres per second (mm<sup>3</sup>/s);

$Q_2$  is the corrected test gas flow exiting the flowmeter at room temperature, in cubic millimetres per second (mm<sup>3</sup>/s).

Electronic mass flowmeters are not affected by pressure or temperature changes. When such flowmeter is used, test gas pressure and temperature measurements (as well as correction) at the flowmeter is not required.

For a closure test performed at high temperature, the test pressure shall be  $1,1 \times$  the maximum rated pressure at high temperature.

#### 4.1.3 Torque measurement

Torque shall be measured by means of a calibrated torque wrench with maximum torque indicator, strain gauge sensor or other appropriate means. Torque measurement equipment shall have a tolerance accuracy lower than or equal to 5 % at the maximum torque measured.

#### 4.1.4 Temperature measurement

The temperature of the test valve shall be measured at the following three locations, as shown in [Figure 1](#) and recorded in a test report.

- a) Measurement at location 1 shall be used to determine the test temperature.
- b) Measurement at location 2 is for information; any use of insulation shall be detailed in the test report.
- c) Measurement at location 3 is used to determine the external valve temperature adjacent to the stem (or shaft) seal(s) for information. For a valve provided with extended bonnet, the thermocouple shall be located on the stuffing box, at the top of the extension.
- d) Measurement at location 4 is an option if the measurement location 1 is not possible (except in the case where heating elements penetrate the blind flanges).

All temperatures at location 1 (optionally 4), location 2 and location 3 shall be stabilized before leakage is measured. Temperature at location 1 (optionally 4) shall be stabilized for minimum 10 min prior to leakage measurement (see [Figures 1](#) and [2](#)).

Check if the temperature variation is within  $\pm 5 \%$ , or  $\pm 15 \text{ }^\circ\text{C}$ , whichever is less.

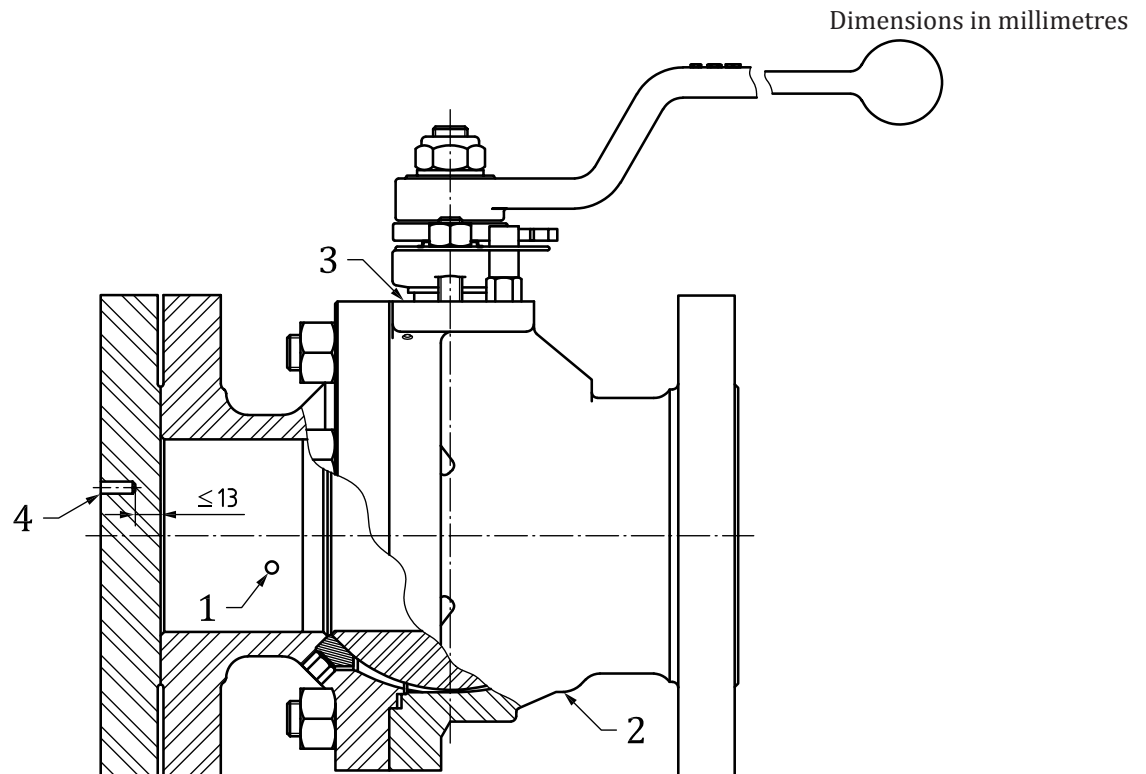
**Key**

- 1 location 1: internal flow path (temperature  $T_1$ )
- 2 location 2: valve body, close to the seat (temperature  $T_2$ )
- 3 location 3: stuffing box (temperature  $T_3$ )
- 4 location 4: optional for flow path when location 1 is not possible (temperature  $T_4$ ); maximum depth is 13 mm

**Figure 1 — Temperature measurements**