



Designation: D7042 – 11

Standard Test Method for Dynamic Viscosity and Density of Liquids by Stabinger Viscometer (and the Calculation of Kinematic Viscosity)¹

This standard is issued under the fixed designation D7042; the number immediately following the designation indicates the year of original adoption or, in the case of revision, the year of last revision. A number in parentheses indicates the year of last reapproval. A superscript epsilon (ϵ) indicates an editorial change since the last revision or reapproval.

1. Scope

1.1 This test method covers and specifies a procedure for the concurrent measurement of both the dynamic viscosity, η , and the density, ρ , of liquid petroleum products and crude oils, both transparent and opaque. The kinematic viscosity, ν , can be obtained by dividing the dynamic viscosity, η , by the density, ρ , obtained at the same test temperature.

1.2 The result obtained from this test method is dependent upon the behavior of the sample and is intended for application to liquids for which primarily the shear stress and shear rate are proportional (Newtonian flow behavior).

1.3 While the precision has only been determined for base oils in the viscosity range from 2.05 to 456 mPa·s at 40°C and from 0.83 to 31.6 mPa·s at 100°C and in the density range from 0.82 to 0.92 g/cm³ at 15°C (see 15.5), the test method can be applied to a wider range of materials, viscosity, density, and temperature. For materials not listed in Precision and Bias (Section 15), the precision and bias may not be applicable.

1.4 The values stated in SI units are to be regarded as the standard. No other units of measurement are included in this standard.

1.5 *This standard does not purport to address all of the safety concerns, if any, associated with its use. It is the responsibility of the user of this standard to establish appropriate safety and health practices and to determine the applicability of regulatory limitations prior to use.*

2. Referenced Documents

2.1 ASTM Standards:²

D445 Test Method for Kinematic Viscosity of Transparent and Opaque Liquids (and Calculation of Dynamic Viscosity)

D2162 Practice for Basic Calibration of Master Viscometers

¹ This test method is under the jurisdiction of ASTM Committee D02 on Petroleum Products and Lubricants and is the direct responsibility of Subcommittee D02.07 on Flow Properties.

Current edition approved Feb. 15, 2011. Published March 2011. Originally approved in 2004. Last previous edition approved in 2010 as D7042–10. DOI:10.1520/D7042-11.

² For referenced ASTM standards, visit the ASTM website, www.astm.org, or contact ASTM Customer Service at service@astm.org. For *Annual Book of ASTM Standards* volume information, refer to the standard's Document Summary page on the ASTM website.

and Viscosity Oil Standards

D2270 Practice for Calculating Viscosity Index from Kinematic Viscosity at 40 and 100°C

D4052 Test Method for Density, Relative Density, and API Gravity of Liquids by Digital Density Meter

D6299 Practice for Applying Statistical Quality Assurance and Control Charting Techniques to Evaluate Analytical Measurement System Performance

D6300 Practice for Determination of Precision and Bias Data for Use in Test Methods for Petroleum Products and Lubricants

D6617 Practice for Laboratory Bias Detection Using Single Test Result from Standard Material

D6708 Practice for Statistical Assessment and Improvement of Expected Agreement Between Two Test Methods that Purport to Measure the Same Property of a Material

2.2 ISO Standards:³

ISO 5725 Accuracy (trueness and precision) of measurement methods and results

ISO/IEC 17025 General Requirements for the Competence of Testing and Calibration Laboratories

2.3 Other Documents:⁴

NIST Technical Note 1297 Guideline for Evaluating and Expressing the Uncertainty of NIST Measurement Results

3. Terminology

3.1 Definitions:

3.1.1 *dynamic viscosity* (η), n —the ratio between the applied shear stress and rate of shear of a liquid.

3.1.1.1 *Discussion*—It is sometimes called the coefficient of dynamic viscosity or, simply, viscosity. Thus, dynamic viscosity is a measure of the resistance to flow or to deformation of a liquid under external shear forces.

3.1.1.2 *Discussion*—The term dynamic viscosity can also be used in a different context to denote a frequency-dependent quantity in which shear stress and shear rate have a sinusoidal time dependence.

3.1.2 *kinematic viscosity* (ν), n —the ratio of the dynamic viscosity (η) to the density (ρ) of a liquid.

³ Available from American National Standards Institute (ANSI), 25 W. 43rd St., 4th Floor, New York, NY 10036, <http://www.ansi.org>.

⁴ Available from National Institute of Standards and Technology (NIST), 100 Bureau Dr., Stop 1070, Gaithersburg, MD 20899-1070, <http://www.nist.gov>.

3.1.2.1 *Discussion*—For gravity flow under a given hydrostatic head, the pressure head of a liquid is proportional to its density (ρ). Therefore the kinematic viscosity (ν) is a measure of the resistance to flow of a liquid under gravity.

3.1.3 *density* (ρ), n —mass per unit volume.

3.1.4 *Relative density (also called specific gravity (SG))*, n —the ratio of the density of a material at a stated temperature to the density of a reference material (usually water) at a stated temperature.

4. Summary of Test Method

4.1 The test specimen is introduced into the measuring cells, which are at a closely controlled and known temperature. The measuring cells consist of a pair of rotating concentric cylinders and an oscillating U-tube. The dynamic viscosity is determined from the equilibrium rotational speed of the inner cylinder under the influence of the shear stress of the test specimen and an eddy current brake in conjunction with adjustment data. The density is determined by the oscillation frequency of the U-tube in conjunction with adjustment data. The kinematic viscosity is calculated by dividing the dynamic viscosity by the density.

5. Significance and Use

5.1 Many petroleum products, and some non-petroleum materials, are used as lubricants and the correct operation of the equipment depends upon the appropriate viscosity of the liquid being used. In addition, the viscosity of many petroleum fuels is important for the estimation of optimum storage, handling, and operational conditions. Thus, the accurate determination of viscosity is essential to many product specifications.

5.2 Density is a fundamental physical property that can be used in conjunction with other properties to characterize both the light and heavy fractions of petroleum and petroleum products.

5.3 Determination of the density or relative density of petroleum and its products is necessary for the conversion of measured volumes to volumes at the standard temperature of 15°C.

6. Apparatus

6.1 *Stabinger Viscometer*^{5,6}

6.1.1 *Viscosity measurement*—The Stabinger viscometer uses a rotational coaxial cylinder measuring system. The outer cylinder (tube) is driven by a motor at a constant and known rotational speed. The low-density inner cylinder (rotor) is held in the axis of rotation by the centrifugal forces of the higher density sample and in its longitudinal position by the magnet

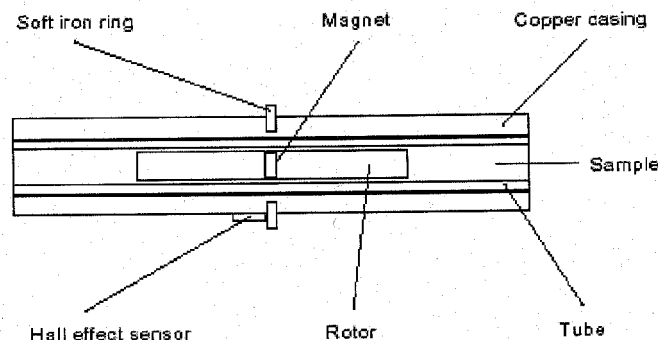

FIG. 1 Viscosity Cell

and the soft iron ring. Consequently, the system works free of bearing friction as found in rotational viscometers. A permanent magnet in the inner cylinder induces eddy currents in the surrounding copper casing. The rotational speed of the inner cylinder establishes itself as the result of the equilibrium between the driving torque of the viscous forces and the retarding eddy current torque. This rotational speed is measured by an electronic system (Hall effect sensor) by counting the frequency of the rotating magnetic field (see Fig. 1 and Fig. 2, No. 2).

6.1.2 *Density Measurement*—The digital density analyzer uses a U-shaped oscillating sample tube and a system for electronic excitation and frequency counting (see Fig. 2, No. 3).

6.1.3 *Temperature Control*—The copper block surrounds both the viscosity and the density measuring cell in a way that both cells are held at the same temperature. A thermoelectric heating and cooling system (see Fig. 2, No. 1) ensures the temperature stability of the copper block within $\pm 0.005^\circ\text{C}$ from the set temperature at the position of the viscosity cell over the whole temperature range. The uncertainty ($k = 2$; 95 % confidence level) of the temperature calibration shall be no more than $\pm 0.03^\circ\text{C}$ over the range from 15 to 100°C. Outside this range the calibration uncertainty shall be no more than $\pm 0.05^\circ\text{C}$.

6.1.4 The thermal equilibration time depends on the heat capacity and conductivity of the liquid and on the difference between injection temperature and test temperature. Adequate temperature equilibration of the test specimen is automatically determined when successive viscosity values are constant within $\pm 0.07\%$ over 1 min and successive density values are constant within $\pm 0.00003\text{ g/cm}^3$ over 60 s.

NOTE 1—The Stabinger Viscometer, manufactured by Anton Paar GmbH, fulfills the stated requirements when operated in the most precise mode of operation.

6.2 *Syringes*, commercially available, at least 5 mL in volume, with a Luer tip. All construction materials for syringes shall be fully compatible with all sample liquids and cleaning agents, which contact them.

6.3 *Flow-Through or Pressure Adapter*, for use as an alternative means of introducing the test specimen into the measuring cells either by pressure or by suction, provided that sufficient care and control is used to avoid any bubble

⁵ The Stabinger viscometer is covered by a patent. Interested parties are invited to submit information regarding the identification of an alternative to this patented item to the ASTM International headquarters. Your comments will receive careful consideration at a meeting of the responsible technical committee, which you may attend.

⁶ The sole source of supply of the apparatus known to the committee at this time is Anton Paar GmbH, Anton-Paar-Str. 20, A-8054 Graz, Austria. If you are aware of alternative suppliers, please provide this information to ASTM International headquarters. Your comments will receive careful consideration at a meeting of the responsible technical committee, which you may attend.

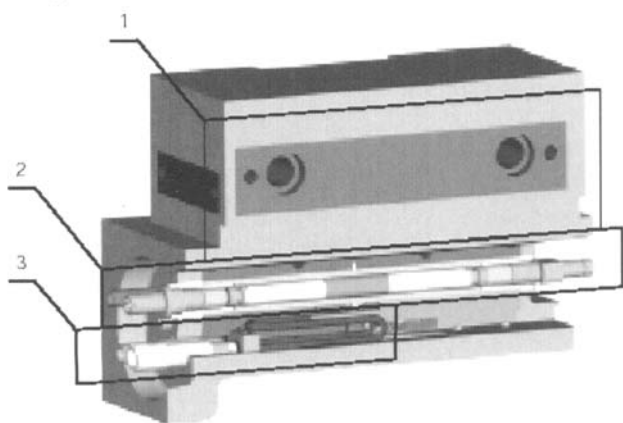

FIG. 2 Cell Block

formation in the test specimen. All construction materials for adaptors shall be fully compatible with all sample liquids and cleaning agents, which contact them.

6.4 *Screen*, with an aperture of 75 μm , to remove particles from the sample.

6.5 *Magnet*, strong enough to remove iron fillings from the sample. Magnetic stirring rods are suitable.

7. Reagents and Materials

7.1 *Sample Solvent*, completely miscible with the sample.

7.1.1 For most samples, a volatile petroleum spirit or naphtha is suitable. If the solvent dries up without residues in an applicable time frame, the use of a separate drying solvent is not required.

7.1.2 For residual fuels, a prewash with an aromatic solvent such as toluene or xylene may be necessary to remove asphaltic material.

7.2 *Drying Solvent*, a volatile solvent miscible with the sample solvent (see 7.1).

7.2.1 Highly concentrated ethanol (96 % or higher) is suitable.

7.3 *Dry Air or Nitrogen*, for blowing the measuring cells.

7.3.1 If the measuring cell temperature is below or near the dew point temperature of the ambient air, the use of an appropriate desiccator is required.

8. Sampling, Test Specimens, and Test Units

8.1 Sampling is defined as all the steps required to obtain an aliquot of the contents of any pipe, tank, or other system, and to place the sample into the laboratory test container. The laboratory test container and sample volume shall be of sufficient capacity to mix the sample and obtain a homogeneous sample for analysis.

8.2 *Particles*—For samples that are likely to contain particles (for example, used oils or crude oils) pass the sample through a 75- μm screen to remove the particles. For the removal of iron fillings the use of a magnet is appropriate. Waxy samples must be heated to dissolve the wax crystals prior to filtration and a preheated filter shall be used.

8.3 *Test Specimen*—A portion or volume of sample obtained from the laboratory sample and delivered to the measuring cells. The test specimen is obtained as follows:

8.3.1 Mix the sample, if required, to homogenize. Mixing at room temperature in an open container can result in the loss of volatile material; mixing in closed, pressurized containers, or at sub-ambient temperatures is recommended.

8.3.2 Draw the test specimen from a properly mixed laboratory sample using an appropriate syringe. Alternatively, if the proper attachments and connecting tubes are used, the test specimen can be delivered directly to the measuring cells from the mixing container. For waxy or other samples with a high pour point, before drawing the test specimen, heat the laboratory sample to the desired test temperature, which has to be high enough to dissolve the wax crystals.

9. Calibration and Verification

9.1 Use only a calibrated apparatus as described in 6.1. The calibration shall be checked periodically using certified reference standards as described in 9.2 and 9.3. The recommended interval for viscosity and density calibration is once a month, for temperature control once a year. For the calibration procedure follow the instructions of the manufacturer of the apparatus.

9.2 *Certified Viscosity and Density Reference Standards*—These are for use as confirmatory checks on the procedure in the laboratory. Certified viscosity and density reference standards shall be certified by a laboratory, which has shown to meet the requirements of **ISO/IEC 17025** or a corresponding national standard by independent assessment. Viscosity standards shall be traceable to master viscometer procedures described in Test Method **D2162**. Density standards shall have a certified uncertainty of the density values of 0.0001 g/cm^3 . The uncertainty of the reference standards shall be stated for each certified value ($k = 2$; 95 % confidence level). See **ISO 5725** or **NIST Technical Note 1297**.

9.3 *Thermometer*—For calibration and adjustment of the temperature control, a digital thermometer with a probe diameter of 6.25 mm and a maximal length of 80 mm shall be used. For smaller probes the use of an adapter is suitable. The uncertainty ($k = 2$; 95 % confidence level) of this thermometer must be no more than $\pm 0.01^\circ\text{C}$ and has to be certified by a laboratory which has shown to meet the requirements of **ISO/IEC 17025** or a corresponding national standard by independent assessment. A suitable thermometer is available from the manufacturer of the apparatus.

9.4 *Acceptable Tolerance*—If the determined values of a calibration check measurement do not agree within the acceptable tolerance band of the certified values, as calculated from **Annex A1**, re-check each step in the procedure, including the special cleaning procedure from 12.2, to locate the source of error.

NOTE 2—Values exceeding the acceptable tolerance are generally attributable to deposits in the measuring cells that are not removed by the routine flushing procedure.