



SLOVENSKI STANDARD
oSIST prEN ISO 12183:2023
01-december-2023

Tehnologija jedrskih goriv - Kulometrična meritev plutonija z nadzorovanim potencialom (ISO/DIS 12183:2023)

Nuclear fuel technology - Controlled-potential coulometric measurement of plutonium (ISO/DIS 12183:2023)

Kernbrennstofftechnologie - Coulometrische Bestimmung von Plutonium mit kontrolliertem Potential (ISO/DIS 12183:2023)

Technologie du combustible nucléaire - Dosage du plutonium par coulométrie à potentiel imposé (ISO/DIS 12183:2023)

Ta slovenski standard je istoveten z: prEN ISO 12183

oSIST prEN ISO 12183:2023

ICS:

27.120.30	Cepljivi materiali in jedrska gorivna tehnologija	Fissile materials and nuclear fuel technology
-----------	---	---

oSIST prEN ISO 12183:2023

en,fr,de

DRAFT INTERNATIONAL STANDARD

ISO/DIS 12183

ISO/TC 85/SC 5

Secretariat: BSI

Voting begins on:
2023-09-27Voting terminates on:
2023-12-20

Nuclear fuel technology — Controlled-potential coulometric measurement of plutonium

ICS: 27.120.30

iTeh Standards (<https://standards.iteh.ai>) Document Preview

[oSIST prEN ISO 12183:2023](https://standards.iteh.ai/catalog/standards/sist/1abca302-9aa6-44a9-9ef5-216e59dcb312/osist-pren-iso-12183-2023)<https://standards.iteh.ai/catalog/standards/sist/1abca302-9aa6-44a9-9ef5-216e59dcb312/osist-pren-iso-12183-2023>

This document is circulated as received from the committee secretariat.

THIS DOCUMENT IS A DRAFT CIRCULATED FOR COMMENT AND APPROVAL. IT IS THEREFORE SUBJECT TO CHANGE AND MAY NOT BE REFERRED TO AS AN INTERNATIONAL STANDARD UNTIL PUBLISHED AS SUCH.

IN ADDITION TO THEIR EVALUATION AS BEING ACCEPTABLE FOR INDUSTRIAL, TECHNOLOGICAL, COMMERCIAL AND USER PURPOSES, DRAFT INTERNATIONAL STANDARDS MAY ON OCCASION HAVE TO BE CONSIDERED IN THE LIGHT OF THEIR POTENTIAL TO BECOME STANDARDS TO WHICH REFERENCE MAY BE MADE IN NATIONAL REGULATIONS.

RECIPIENTS OF THIS DRAFT ARE INVITED TO SUBMIT, WITH THEIR COMMENTS, NOTIFICATION OF ANY RELEVANT PATENT RIGHTS OF WHICH THEY ARE AWARE AND TO PROVIDE SUPPORTING DOCUMENTATION.

ISO/CEN PARALLEL PROCESSING



Reference number
ISO/DIS 12183:2023(E)

© ISO 2023

iTeh Standards
(<https://standards.iteh.ai>)
Document Preview

[oSIST prEN ISO 12183:2023](https://standards.iteh.ai/catalog/standards/sist/1abca302-9aa6-44a9-9ef5-216e59dcb312/osist-pren-iso-12183-2023)

<https://standards.iteh.ai/catalog/standards/sist/1abca302-9aa6-44a9-9ef5-216e59dcb312/osist-pren-iso-12183-2023>



COPYRIGHT PROTECTED DOCUMENT

© ISO 2023

All rights reserved. Unless otherwise specified, or required in the context of its implementation, no part of this publication may be reproduced or utilized otherwise in any form or by any means, electronic or mechanical, including photocopying, or posting on the internet or an intranet, without prior written permission. Permission can be requested from either ISO at the address below or ISO's member body in the country of the requester.

ISO copyright office
CP 401 • Ch. de Blandonnet 8
CH-1214 Vernier, Geneva
Phone: +41 22 749 01 11
Email: copyright@iso.org
Website: www.iso.org

Published in Switzerland

Contents

	Page
Foreword.....	iv
1 Scope.....	1
2 Normative references.....	1
3 Terms and definitions.....	1
4 Principle.....	1
5 Reagents.....	2
6 Apparatus.....	3
7 Procedure.....	7
7.1 Plutonium determination.....	7
7.2 Analysis of subsequent test samples.....	14
8 Expression of quantity values.....	14
8.1 Calculation of the electrical calibration factor.....	14
8.2 Calculation of the blank.....	15
8.3 Fraction of electrolysed plutonium.....	15
8.4 Plutonium, amount of substance and mass.....	16
8.5 Quality control.....	17
9 Characteristics of the method.....	17
9.1 Repeatability.....	17
9.2 Confidence interval.....	17
9.3 Analysis time.....	17
10 Interferences.....	17
11 Procedure variations and optimization.....	21
11.1 Accountability measurements and reference material preparation.....	21
11.2 Process control measurements.....	21
11.3 Measurement cell design.....	22
11.4 Electrolyte and electrode options.....	22
11.5 Test sample size.....	23
11.6 Background current corrections.....	23
11.7 Correction for iron.....	24
11.8 Control-potential adjustment.....	24
11.9 Calibration methodologies.....	25
12 Traceability to SI units.....	25
Annex A (normative) Purification by anion-exchange separation.....	26
Annex B (normative) Determination of formal potential, E_0.....	28
Bibliography.....	29

ISO/DIS 12183:2023(E)

Foreword

ISO (the International Organization for Standardization) is a worldwide federation of national standards bodies (ISO member bodies). The work of preparing International Standards is normally carried out through ISO technical committees. Each member body interested in a subject for which a technical committee has been established has the right to be represented on that committee. International organizations, governmental and non-governmental, in liaison with ISO, also take part in the work. ISO collaborates closely with the International Electrotechnical Commission (IEC) on all matters of electrotechnical standardization.

The procedures used to develop this document and those intended for its further maintenance are described in the ISO/IEC Directives, Part 1. In particular, the different approval criteria needed for the different types of ISO documents should be noted. This document was drafted in accordance with the editorial rules of the ISO/IEC Directives, Part 2 (see www.iso.org/directives).

Attention is drawn to the possibility that some of the elements of this document may be the subject of patent rights. ISO shall not be held responsible for identifying any or all such patent rights. Details of any patent rights identified during the development of the document will be in the Introduction and/or on the ISO list of patent declarations received (see www.iso.org/patents).

Any trade name used in this document is information given for the convenience of users and does not constitute an endorsement.

For an explanation on the meaning of ISO specific terms and expressions related to conformity assessment, as well as information about ISO's adherence to the World Trade Organization (WTO) principles in the Technical Barriers to Trade (TBT) see the following URL: www.iso.org/iso/foreword.html.

The committee responsible for this document is Technical Committee ISO/TC 85, *Nuclear energy, nuclear technologies, and radiological protection*, Subcommittee SC 5, *Nuclear fuel cycle*.

This fourth edition cancels and replaces the third edition (ISO 12183:2016), which has been technically revised.

[oSIST prEN ISO 12183:2023](https://standards.iteh.ai/catalog/standards/sist/1abca302-9aa6-44a9-9ef5-216e59deb312/osist-pren-iso-12183-2023)

<https://standards.iteh.ai/catalog/standards/sist/1abca302-9aa6-44a9-9ef5-216e59deb312/osist-pren-iso-12183-2023>

Nuclear fuel technology — Controlled-potential coulometric measurement of plutonium

1 Scope

This document describes an analytical method for the electrochemical measurement of pure plutonium nitrate solutions of nuclear grade, with an expanded uncertainty not exceeding $\pm 0,2\%$ at the confidence level of 0,95 for a single determination (coverage factor, $k = 2$). The method is suitable for aqueous solutions containing plutonium at more than 0,5 g/L and test samples containing plutonium between 4 mg and 15 mg. Application of this technique to solutions containing plutonium at less than 0,5 g/L and test samples containing plutonium at less than 4 mg requires experimental demonstration by the user that applicable data quality objectives will be met.

For some applications, the purification of test samples by anion exchange is required before measurement to remove interfering substances present in significant amounts. [Clause 10](#) provides a discussion of interferences and corrective actions. Purification is also appropriate in situations where the purity of the test sample is unknown or when it may fluctuate unpredictably in a manufacturing process.

[Clause 11](#) discusses the changes in application of the method and methodology that can be applied and important considerations when selecting measurement parameters, while still remaining within the intended scope of this document.

2 Normative references

ISO 3696, *Water for analytical laboratory use — Specification and test methods*^[1]

3 Terms and definitions

No terms and definitions are listed in this document.

ISO and IEC maintain terminological databases for use in standardization at the following addresses:

- IEC Electropedia: available at <https://www.electropedia.org/>
- ISO Online browsing platform: available at <https://www.iso.org/obp>

4 Principle

The key steps and their purposes are outlined below:

- test samples are prepared from homogenous solutions by weighing and then fuming to dryness with sulfuric acid to achieve a stable anhydrous plutonium sulfate salt that is free from chloride, fluoride, nitrate, nitrite, hydroxylamine, and volatile organic compounds;
- if needed to remove interferences, dissolve test samples and purify by anion exchange, then fume the eluted plutonium solution in the presence of sulfuric acid to obtain the anhydrous plutonium sulfate salt;
- measure the supporting electrolyte blank and calculate the background current correction applicable to the electrolysis of the test sample from charging, faradaic, and residual currents^[2];
- dissolve the dried test sample in the previously measured supporting electrolyte (the blank);

ISO/DIS 12183:2023(E)

- reduce the test sample at a controlled potential that electrolyses the plutonium to a Pu^{3+} fraction greater than 99,8 % and measure the equilibrium solution potential at the end of this step by control-potential adjustment^[3];
- oxidize the test sample at a controlled potential that electrolyses the plutonium to a Pu^{4+} fraction greater than 99,8 % and measure the equilibrium solution potential at the end of this electrolysis by control-potential adjustment;
- correct the integrated current (integrator output from the test sample) for the background current, including the residual current corrections, and for the fraction of plutonium not electrolysed;
- calibrate the coulometer using traceable electrical standards and Ohm's Law;
- use the measured value of the electrical calibration factor and the Faraday constant to convert the integrator output to coulombs and then to moles of plutonium measured by the coulometer;
- calculate the mass of plutonium by multiplying the moles of plutonium determined by controlled-potential coulometry times a molar mass of plutonium determined by other means, such as thermal ionization mass spectrometry, magnetic sector inductively coupled plasma mass spectrometry, or process knowledge.
- use quality-control standards with traceable plutonium quantity values to demonstrate independently the performance of the measurement system;
- periodically measure the formal potential of the plutonium couple, E_0 , which is user-specific based on the cell design, connections, reference electrode type, acid-type and molarity of the supporting electrolyte, and the presence of any complexing agents in the electrolyte.

These steps ensure that test samples are taken from reproducible and stable sample solutions and prepared for measurement. The test samples are measured using a protocol based upon first principles and a traceable, electrical calibration of the coulometer. Further details are provided in [Clauses 10](#) and [11](#).

5 Reagents

Use only analytical grade reagents.

All aqueous solutions shall be prepared with double-distilled or distilled, demineralized water with a resistivity greater than 10 $\text{M}\Omega\cdot\text{cm}$, i.e. ISO 3696^[1] Grade 1 purified water.

5.1 Nitric acid solution, $c(\text{HNO}_3) = 0,9 \text{ mol/L}$.

NOTE Refer to [11.4](#) for alternative electrolyte options.

5.2 Amidosulfuric acid solution, $c(\text{NH}_2\text{HSO}_3) = 1,5 \text{ mol/L}$.

5.3 Sulfuric acid solution, $c(\text{H}_2\text{SO}_4) = 3 \text{ mol/L}$.

NOTE The concentration of the sulfuric acid solution used to fume the plutonium test samples is not a critical parameter, provided the sulfate ion concentration remains in large excess (above 50) compared to the plutonium ion in order to avoid the formation of colloidal Pu complexes.

5.4 Pure argon or nitrogen, (O_2 amount fraction less than 10 $\mu\text{mol/mol}$).

5.5 Pure air (optional reagent), free of organic contaminants.

6 Apparatus

Usual laboratory equipment found in a medium-activity-radiochemical laboratory suitable for work with plutonium should be used.

6.1 Analytical balance, installed in radiological containment unit and must be capable of weighing a mass of 1 g, with a standard uncertainty of $\pm 0,1$ mg (coverage factor, $k = 1$). This represents a relative standard uncertainty of 0,01 %.

- Weighing less than 1 g will increase the relative uncertainty to $>0,01$ %, in an inversely proportional manner.
- If the uncertainty of the balance, as installed, does not meet the criterion of $\pm 0,1$ mg, then test samples greater than 1 g should be used.

6.2 Weighing bottle, glass or plastic, the material selection is not critical provided it is chemically inert, maintains a stable mass (tare weight), and static charge is controlled as described in [7.1.1](#).

6.3 Equipment for test sample evaporation in the coulometric cell, comprising of an overhead radiant heater or hot-plate with controls to adjust temperature. Design requirements and optional features for effective evaporation and fuming include:

- providing settings that allow both a rapid and well-controlled rate of initial evaporation, followed by fuming the remaining sulfuric acid solution to dryness at a higher temperature;
- preventing mechanical loss of the test sample solution from boiling and/or spattering;
- preventing contamination by extraneous chemicals, such as those which may be used to neutralize acid vapours;
- heating of the coulometer cell wall to optimize fuming and minimize refluxing of sulfuric acid by placing the cell inside an optional aluminium tube (inner diameter 1 mm to 3 mm larger than the outer diameter of the cell, tube height 1 mm to 5 mm shorter than the cell) may be placed around the cell during the fuming step;

NOTE An aluminium block with holes bored to a similar specification for inserting the cell may be used instead of the aluminium tubes.

- addition of an optional air supply with the delivery tube directed towards the surface of the liquid to optimize the evaporation rate and disperse the acid fumes, with appropriate controls and feature that will depend upon facility design and ventilation system requirements;
- addition of an optional vapour capture and local neutralization to control acid fumes, with appropriate controls and features that will depend upon facility design and ventilation system requirements.

See [Figure 1](#).

Dimensions in millimetres

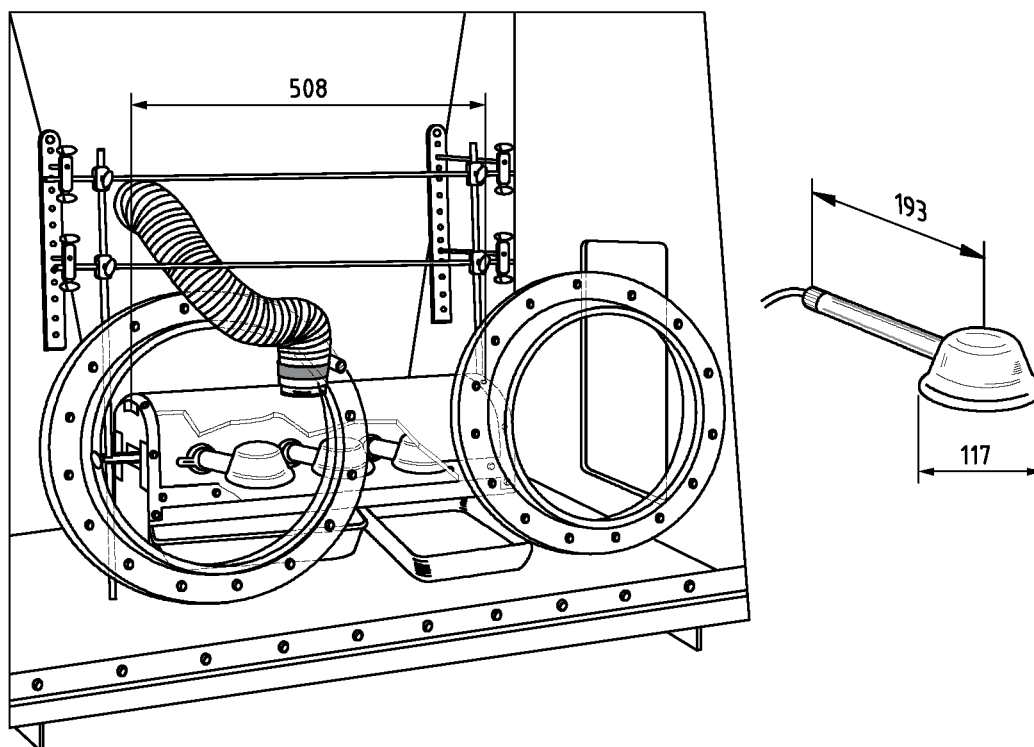

Figure 1 — Sample evaporation system

6.4 Controlled-potential coulometer.

See [Figure 2](#).

6.4.1 Coulometer cell assembly, comprising the following:

- a) a stirrer motor with a rotation frequency of at least $16,7 \text{ s}^{-1}$ ($1\ 000 \text{ min}^{-1}$);

NOTE 1 Adjustable-speed motors allow users to optimize the rate of rotation to the individual cell designs. Stirrer motors powered by isolated DC power supplies are recommended as they prevent electrical noise from being superimposed on the blank and test sample electrolysis current signals sent to the integrator.

- b) a cylindrical or tapered glass coulometric cell of capacity 50 mL, or less.
- c) a tight-fitting lid made from chemically and electrochemically inert material [e.g. polytetrafluoroethylene (PTFE)], that includes an O-ring seal, and with openings to insert the following internal equipment:
- an inlet tube for humidified, inert gas to displace dissolved and atmospheric oxygen from the solution and the electrolysis cell, respectively;
 - a stirrer with blade and shaft made from chemically and electrochemically inert materials [e.g. polytetrafluoroethylene (PTFE)], and designed to prevent splashing; the shaft of the stirrer is typically located in the centre of the cell and connected directly to the stirrer motor;
 - a working electrode made of gold [mass fraction (purity) 99,99 % or greater] and consisting of a gold wire welded or machined to a cylindrical gold wire frame, a nominal height of 15 mm and a diameter of 20 mm, around which is welded or machined a very fine gold mesh, which is typically several layers (e.g. four layers);

NOTE 2 Refer to [11.4](#) for other working electrode options.

- a glass salt bridge tube plugged at the bottom end with a sintered-glass disc (typical thickness of 2,5 mm and pore size of <math><0,01 \mu\text{m}</math>), the tube is filled with nitric acid (5.1) and the tip of the sintered-glass end is positioned within the ring of the working electrode;

NOTE 3 The diameter of the glass salt bridge tube and sintered-glass disc containing the auxiliary (counter) electrode may be larger than that of the glass salt bridge tube and sintered-glass disc containing the reference electrode. The flow rate of the solution through both glass discs should be less than 0,05 mL/h.

- a reference electrode, saturated calomel electrode (SCE), or other reference electrodes as described in 11.3, is inserted into the glass salt bridge tube;
- another glass salt bridge tube, similar to the first one, also filled with nitric acid (5.1), and the tip of the sintered-glass end positioned within the ring of the working electrode;
- an auxiliary (counter) electrode consisting of a platinum wire [mass fraction (purity) 99,95 % or greater] with a diameter of 0,5 mm to 3,0 mm, is inserted into the second glass salt bridge tube;

NOTE 4 The platinum wire may be coiled to increase the surface area submerged in the supporting electrolyte, as illustrated in Figure 2.

- d) a gas washer bottle, filled with reagent water as described in Clause 5, to humidify the inert gas before it is introduced into the coulometer cell assembly.
- e) A thermocouple or resistance thermometer installed in the coulometer cell assembly for measuring the temperature of the test sample solution during the measurement process is an optional feature. The solution temperature should be measured either during the oxidation of the test sample or immediately following the analysis. A goal for the standard uncertainty of the temperature measurement is $\pm 0,2 \text{ }^\circ\text{C}$ ($k = 1$).

NOTE 5 The purge gas is cooled by expansion causing the solution temperature to decrease relative to the ambient temperature; the extent of this decrease is a function of the inert-gas flow rate and the cell design.

NOTE 6 If it is not possible to insert a temperature sensor into the electrolysis cell or not desirable to measure the temperature of the test sample solution immediately after the electrolysis is completed, then the solution temperature can be estimated from the ambient air temperature or the reagent temperature. The measured air or reagent temperature value must be corrected for this cooling effect and a higher standard uncertainty of $\pm 1 \text{ }^\circ\text{C}$, $k = 1$, is expected in the calculated solution temperature.

- f) For optimum potential control, position the sintered-glass discs of the reference and auxiliary electrodes' glass tubes in order to meet the following requirements:
 - the closest distance from the reference electrode sintered-glass disc to the working electrode is 2 mm or less;
 - the distance between the two sintered-glass discs containing the auxiliary and reference electrodes is less than the distance between the auxiliary electrode disc and the nearest point on the working electrode.
- g) The hole through which the stirrer shaft is inserted serves as the primary escape vent for the inert gas. Except for this hole, all other insertions are tight fitting. The inert-gas flow rate must be sufficiently high such that it removes oxygen quickly from the supporting electrolyte and the test sample solution. Furthermore, it must prevent leakage of air into the cell assembly during the electrolysis. A practical guide for adjusting the flow rate is to direct all or part of the inert gas supply toward the solution, such that a dimple is formed on the surface with a depth of 2 mm to 4 mm without causing the solution to splash. An inert gas flow rate of $0,000 \text{ 1 m}^3 \text{ s}^{-1}$ ($100 \text{ cm}^3 \text{ s}^{-1}$) is sufficient for the coulometer cell assembly illustrated in Figure 2.

NOTE 7 Cell assemblies with an optimized design, an adequate inert-gas flow rate, and a tight fit, will remove oxygen from nitric acid supporting electrolyte in 150 s (2.5 min) or less. Due to the variabilities of factors involved (e.g. cell geometry, volume of electrolyte), the time required to remove oxygen from the solution should be established by users based on testing of their cell assembly under routine conditions.