

INTERNATIONAL STANDARD

ISO 2692

First edition
1988-12-15

AMENDMENT 1
1992-10-01

Technical drawings — Geometrical tolerancing — Maximum material principle

AMENDMENT 1: Least material requirement

iTeh STANDARD PREVIEW
(standards.iteh.ai)

*Dessins techniques — Tolérancement géométrique — Principe du maximum de
matière*

[https://standards.iteh.ai/catalog/standards/sist/b42a8ea1-e04e-415d-b5db-](https://standards.iteh.ai/catalog/standards/sist/b42a8ea1-e04e-415d-b5db-4352d6b059d/iso-2692-1988-amd-1-1992)

[4352d6b059d/iso-2692-1988-amd-1-1992](https://standards.iteh.ai/catalog/standards/sist/b42a8ea1-e04e-415d-b5db-4352d6b059d/iso-2692-1988-amd-1-1992)

AMENDEMENT 1: Exigence du minimum de matière

INTERNATIONAL

ISO



Reference number
ISO 2692 : 1988/Amd.1 : 1992 (E)

Foreword

ISO (the International Organization for Standardization) is a worldwide federation of national standards bodies (ISO member bodies). The work of preparing International Standards is normally carried out through ISO technical committees. Each member body interested in a subject for which a technical committee has been established has the right to be represented on that committee. International organizations, governmental and non-governmental, in liaison with ISO, also take part in the work. ISO collaborates closely with the International Electrotechnical Commission (IEC) on all matters of electrotechnical standardization.

Draft International Standards adopted by the technical committees are circulated to the member bodies for voting. Publication as an International Standard requires approval by at least 75 % of the member bodies casting a vote.

Amendment 1 to International Standard ISO 2692 : 1988 was prepared by Technical Committee ISO/TC 10, *Technical drawings, product definition and related documentation*, Sub-Committee SC 5, *Dimensioning and tolerancing*.

Annexes A and B of this Amendment are for information only.

Introduction

This Amendment gives definitions and examples of the application of the “least material requirement (LMR)”, to be indicated on drawings by the symbol \textcircled{L} .

It is closely related to the maximum material principle and is used in controlling minimum wall thickness, preventing breakout, etc.

This Amendment will be incorporated in the second edition of ISO 2692.

iTeh STANDARD PREVIEW (standards.iteh.ai)

[ISO 2692:1988/Amd 1:1992](https://standards.iteh.ai/catalog/standards/sist/b42a8ea1-e04e-415d-b5db-4352d6b05f2d/iso-2692-1988-amd-1-1992)

<https://standards.iteh.ai/catalog/standards/sist/b42a8ea1-e04e-415d-b5db-4352d6b05f2d/iso-2692-1988-amd-1-1992>

iTeh STANDARD PREVIEW
(standards.iteh.ai)

This page intentionally left blank

[ISO 2692:1988/Amd 1:1992](#)

<https://standards.iteh.ai/catalog/standards/sist/b42a8ea1-e04e-415d-b5db-4352d6b05f2d/iso-2692-1988-amd-1-1992>

Technical drawings – Geometrical tolerancing – Maximum material principle

AMENDMENT 1: Least material requirement

iTeh STANDARD PREVIEW (standards.iteh.ai)

1 Scope

This Amendment defines and establishes the “least material requirement” and specifies its application.

2 Definitions

For the purposes of this Amendment, the definitions given in ISO 2692 and the following definitions apply.

2.1 least material virtual condition (LMVC): Boundary of perfect form and of least material virtual size.

2.2 least material virtual size (LMVS): Generated by the collective effect of the least material size (LMS) and the geometrical tolerance followed by the symbol \textcircled{L} .

NOTE 1 For shafts: $\text{LMVS} = \text{LMS} - \text{geometrical tolerance}$
For holes: $\text{LMVS} = \text{LMS} + \text{geometrical tolerance}$

3 Least material requirement (LMR)

The least material requirement permits an increase in the stated geometrical tolerance when the concerned feature departs from its least material condition (LMC).

It is indicated on drawings by the symbol \textcircled{L} placed in the tolerance frame after the tolerance of the toleranced feature or after the datum letter; it specifies,

- when applied to the toleranced feature, that the least material virtual condition (LMVC) shall be fully contained within the material of the actual toleranced feature,
- when applied to the datum, that the boundary of perfect form at least material size may float within the material of the actual datum feature (without violating the actual datum feature surface).

4 Examples of application

Examples of the application of the least material requirement (LMR) are given in annex B.

Annex A (informative)

Illustration of the least material requirement

The least material requirement is illustrated in figure A.1 ; when the feature departs from its least material size, when it was at perfect form, an increase in positional tolerance is allowed, which is equal to the amount of such departure.

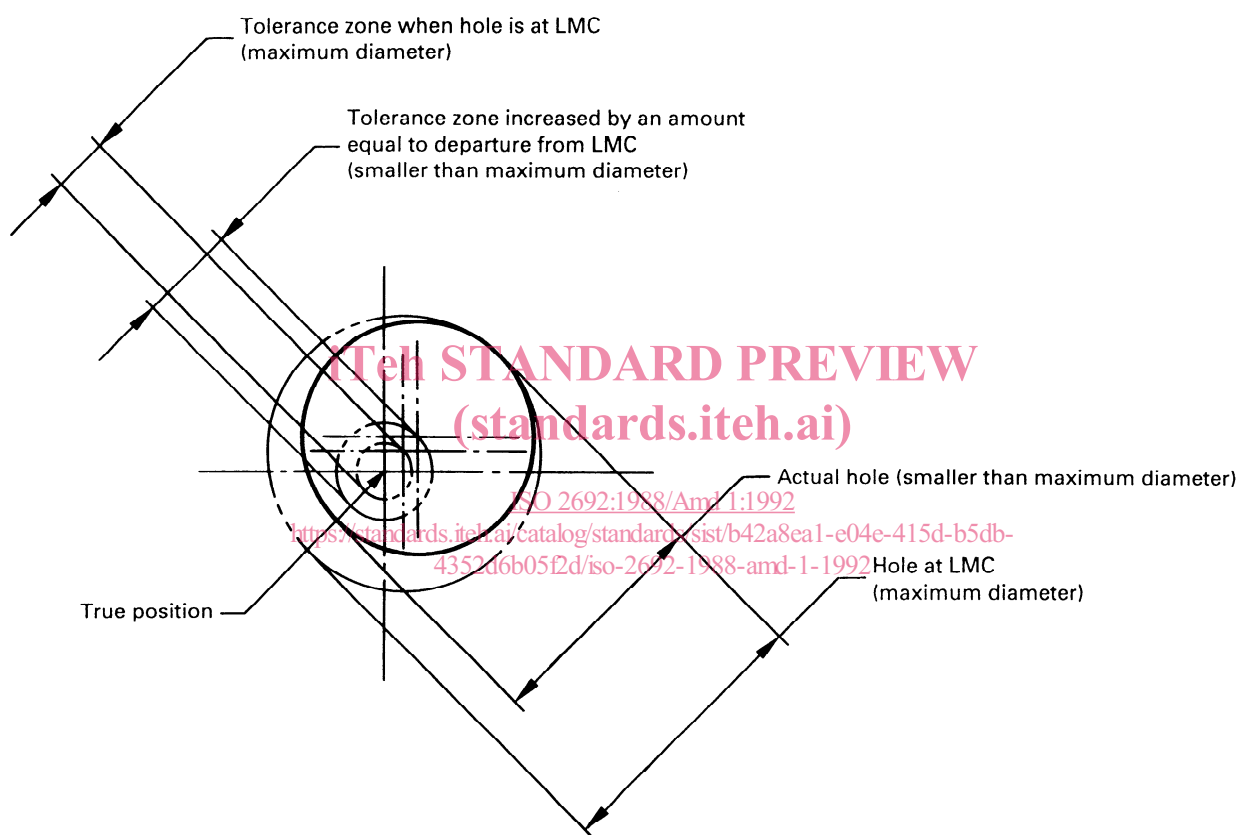
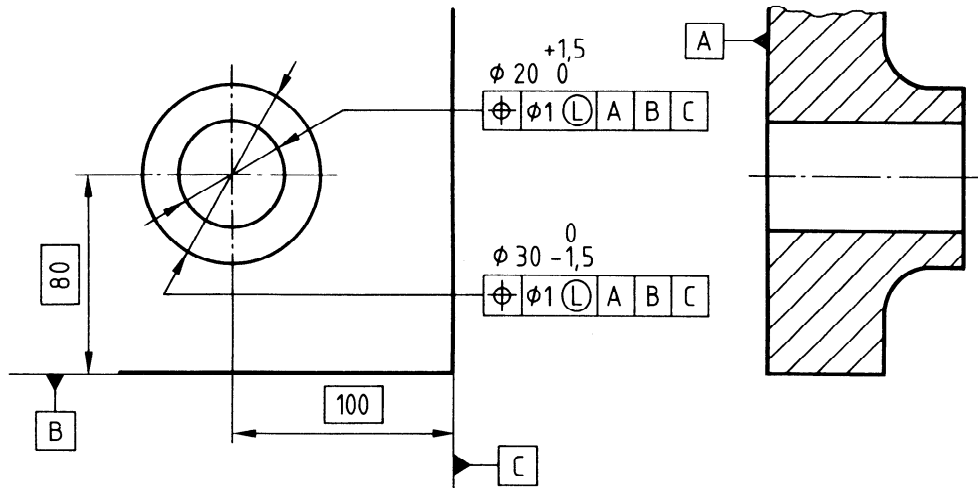

Figure A.1

Annex B (informative)

Examples of indication on the drawing and interpretation



iTeh STANDARD PREVIEW
 a) Indication on the drawing
 (standards.iteh.ai)

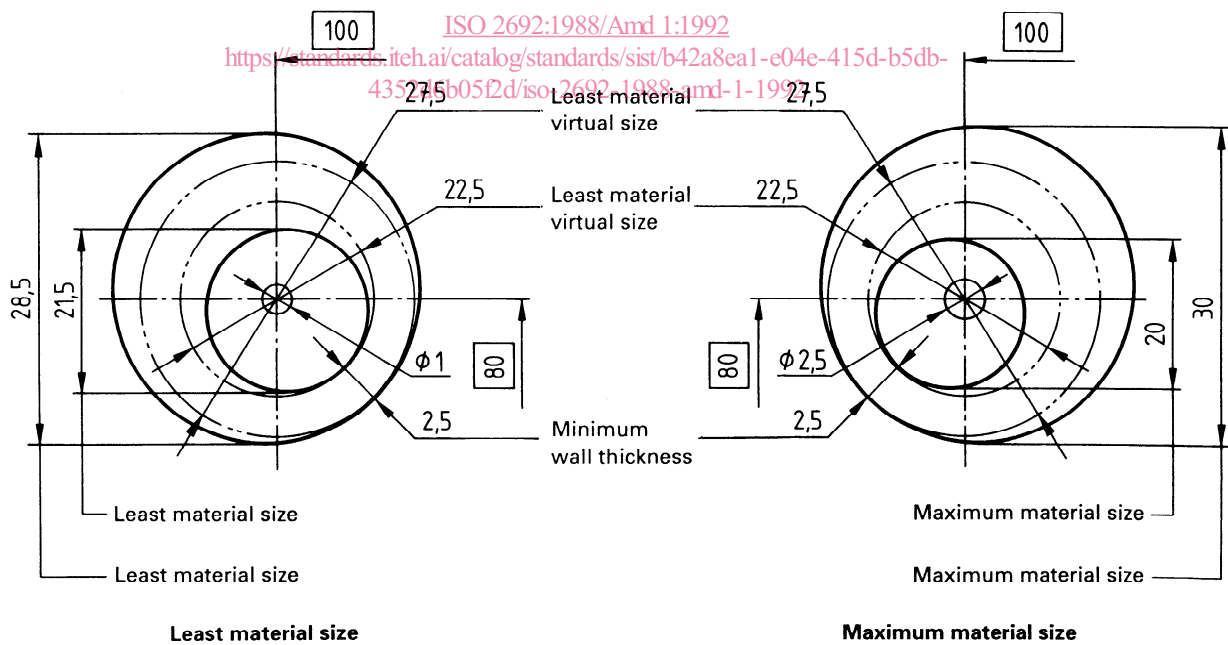

b) Interpretation

Figure B.1 – Least material requirement, minimum wall thickness

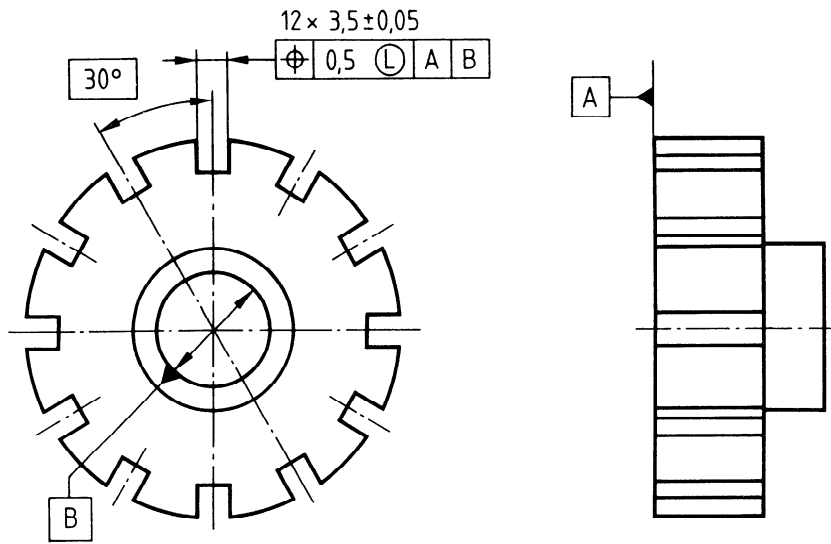

a) Indication on the drawing

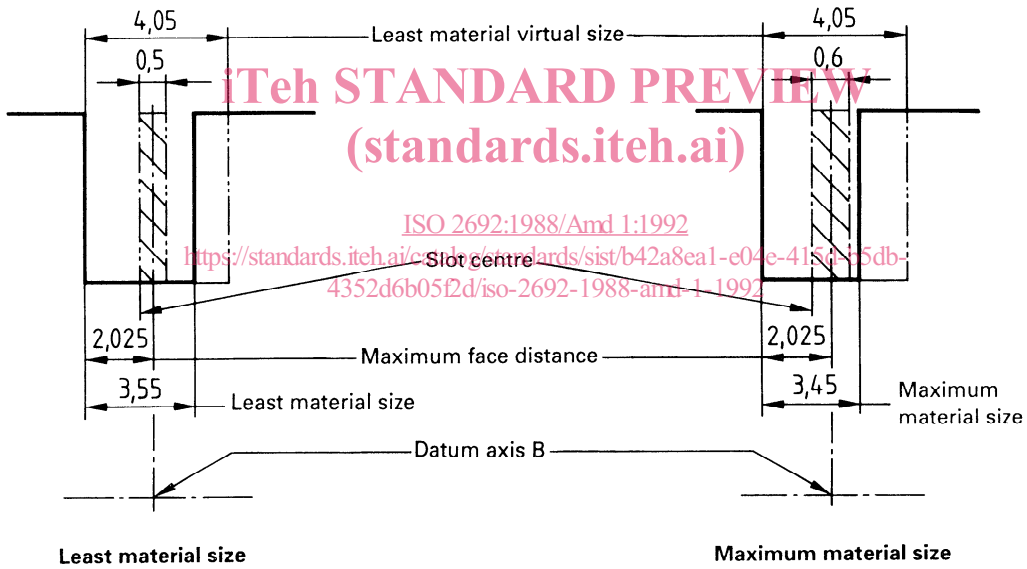

b) Interpretation

Figure B.2 – Least material requirement, maximum face distance

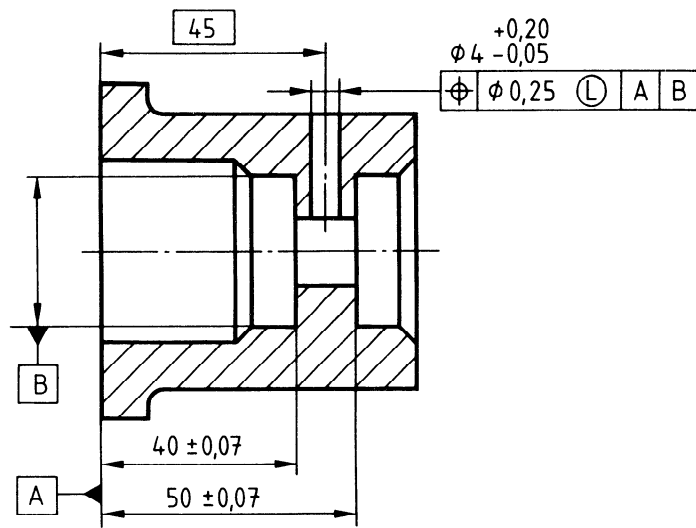

a) Indication on the drawing

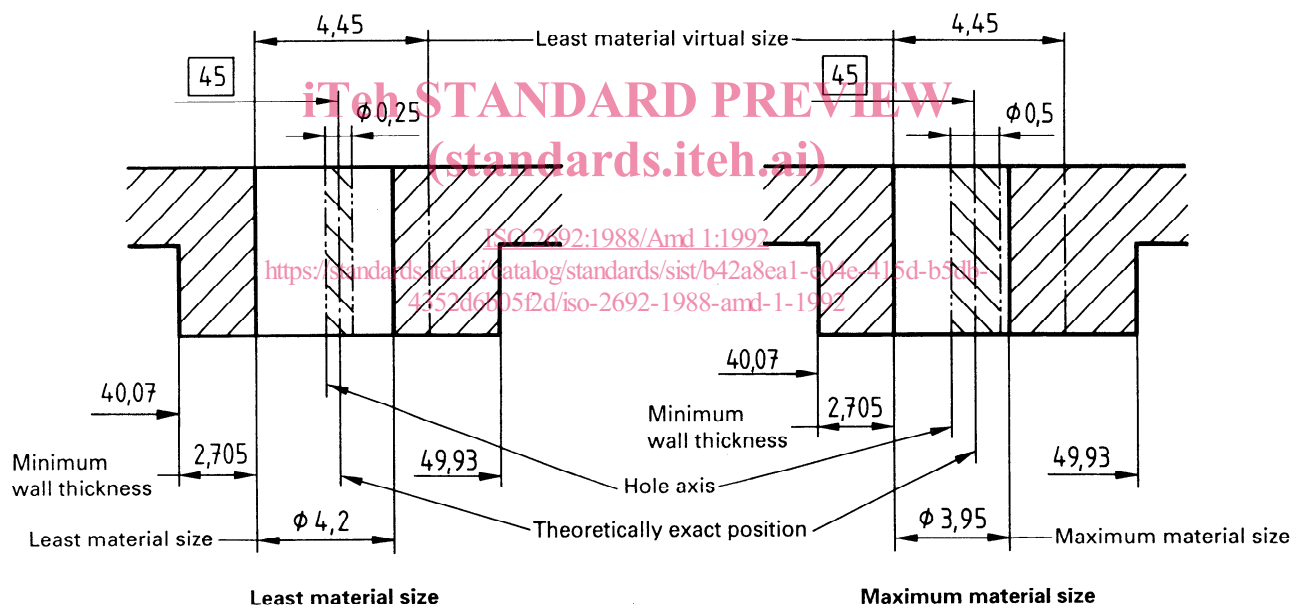

b) Interpretation

Figure B.3 – Least material requirement, minimum wall thickness