



Designation: ~~D5257-03~~ Designation: D5257 - 11

Standard Test Method for Dissolved Hexavalent Chromium in Water by Ion Chromatography¹

This standard is issued under the fixed designation D5257; the number immediately following the designation indicates the year of original adoption or, in the case of revision, the year of last revision. A number in parentheses indicates the year of last reapproval. A superscript epsilon (ϵ) indicates an editorial change since the last revision or reapproval.

1. Scope*

1.1 This test method covers procedures for the determination of dissolved hexavalent chromium in wastewater, surface water, and drinking water.

1.2 The precision and bias of this test method has been tested in reagent water and industrial wastewater and has been found suitable over the range of approximately 1 to 1000 $\mu\text{g/L}$. See Table 1 for details. Higher levels can be determined by appropriate dilution.

~~1.3 Samples containing very high levels of anionic species (that is, chloride, sulfate, etc.) may cause column overload. Samples containing high levels of reducing species (that is, sulfides, sulfites, etc.) may cause reduction of Cr(VI) to Cr(III). This can be minimized by buffering the sample to a pH of 9 to 9.5, filtering it, storing it at 4°C and analyzing it within 24 h.~~

~~1.4 The values stated in SI units are to be regarded as the standard.~~

~~1.3 Samples containing very high levels of anionic species (that is, chloride, sulfate, etc.) may cause column overload. Samples containing high levels of reducing species (that is, sulfides, sulfites, etc.) may cause reduction of Cr(VI) to Cr(III). This can be minimized by buffering the sample to a pH of 9 to 9.5, filtering it, storing it at <6°C. A holding time of 28 days may be used if the user can demonstrate that such holding time does not affect sample integrity per US EPA 40 CFR 136 Part II.~~

~~1.4 The values stated in either SI or inch-pound units are to be regarded as the standard. The values given in parentheses are for information only.~~

1.5 *This standard does not purport to address all of the safety concerns, if any, associated with its use. It is the responsibility of the user of this standard to establish appropriate safety and health practices and determine the applicability of regulatory limitations prior to use.*

2. Referenced Documents

2.1 *ASTM Standards:*²

D1066 Practice for Sampling Steam²

D1129 Terminology Relating to Water

~~D1192 Guide for Equipment for Sampling Water and Steam in Closed Conduits~~ Terminology Relating to Water²

D1193 Specification for Reagent Water²

D2777 Practice for Determination of Precision and Bias of Applicable Test Methods of Committee D19 on Water²

D3370 Practices for Sampling Water from Closed Conduits²

D5810 Guide for Spiking into Aqueous Samples²

D5847 Practice for Writing Quality Control Specifications for Standard Test Methods for Water Analysis

2.2 *EPA Standard:*

EPA Method 218.6 Determination of Dissolved Hexavalent Chromium in Drinking Water, Groundwater and Industrial Wastewater Effluents by Ion Chromatography³

US EPA 40 CFR 136

¹ This test method is under the jurisdiction of ASTM Committee D19 on Water and is the direct responsibility of Subcommittee D19.05 on Inorganic Constituents in Water. Current edition approved Jan. 10, 2003. Published January 2003. Originally approved in 1992. Last previous edition approved in 1997 as D5257-97. DOI: 10.1520/D5257-03.

Current edition approved March 15, 2011. Published April 2011. Originally approved in 1992. Last previous edition approved in 2009 as D5257-09. DOI: 10.1520/D5257-11.

² For referenced ASTM standards, visit the ASTM website, www.astm.org, or contact ASTM Customer Service at service@astm.org. For *Annual Book of ASTM Standards* volume information, refer to the standard's Document Summary page on the ASTM website.

² *Annual Book of ASTM Standards*, Vol 11.01.

³ Available from Superintendent of Documents, U.S. Government Printing Office, Washington, DC 20402.

*A Summary of Changes section appears at the end of this standard.

TABLE 1 Determination of Precision and Bias for Hexavalent Chromium

Water Matrix	Amount Added, µg/L	Amount Found, µg/L	S_t	S_o^A	Bias, %
Reagent	1.2	1.40	0.16	0.15	+ 16.6
	1.6	1.87	0.65	...	+ 16.9
	6.0	6.68	1.03	0.53	+ 11.3
	8.0	8.64	1.10	...	+ 8.0
	16.0	17.4	2.25	0.77	+ 8.8
	20.0	21.4	2.31	...	+ 7.0
	100	101	1.91	3.76	+ 1.0
	140	143	5.52	...	+ 2.1
	800	819	24.3	12.7	+ 2.4
	960	966	18.5	...	+ 7.3
Waste	6.0	5.63	1.17	0.55	-6.2
	8.0	7.31	1.91	...	-8.6
	16.0	15.1	2.70	1.85	-5.6
	20.0	19.8	1.01	...	-1.0
	100	98.9	4.36	3.31	-1.1
	140	138	8.39	...	-1.4
	800	796	60.6	27.1	-0.5
	960	944	72.1	...	-1.7

^AEach Youden pair was used to calculate one lab data point, S_o .

3. Terminology

3.1 *Definitions*—For definitions of terms used in this test method, refer to Terminology D1129.

3.2 *Definitions of Terms Specific to This Standard:*

3.2.1 *eluant*—the ionic mobile phase used to transport the sample through the ion-exchange column.

3.2.2 *resolution*—the ability of a column to separate constituents under specified test conditions.

4. Summary of Test Method

4.1 A fixed volume of buffered and filtered sample, typically 100 µL, is injected into the eluant flow path and separated by anion exchange using an ammonium sulfate based eluant.

4.2 After separation, the sample is reacted with an acidic solution of diphenylcarbohydrazide. Hexavalent chromium reacts selectively with this reagent to form the characteristic violet colored complex.

4.3 The eluant stream passes through a photometric detector for detection of the chromium diphenylcarbohydrazide complex by visible absorbance at 530 nm. Absorbance is proportional to the hexavalent chromium concentration.

5. Significance and Use

5.1 Hexavalent chromium salts are used extensively in the metal finishing and plating industries, in the leather industry as a tanning agent, and in the manufacture of paints, dyes, explosives, and ceramics. Trivalent chromium salts are used as mordants in textile dyeing, in the ceramic and glass industry, and in photography. Chromium, in either oxidation state, may be present in wastewater from these industries and may also be discharged from chromate-treated cooling waters.

5.2 Hexavalent chromium is toxic to humans, animals, and aquatic life. It can produce lung tumors when inhaled and readily induces skin sensitization. It is not known whether cancer will result from ingestion of chromium in any of its valence states.

5.3 Ion chromatography provides a means of separating the hexavalent chromium from other species present in the sample, many of which interfere with other detection methods. The combination of this separation with a sensitive colorimetric detection method provides a selective and sensitive analytical method for hexavalent chromium with minimal sample preparation.

6. Interferences

6.1 By virtue of the chromatographic separation essentially all interfering species are removed from the hexavalent chromium before detection.

6.2 Interferences may result from overloading of the analytical column capacity with high concentrations of anionic species in the sample. Concentrations of chloride ion or sulfate ion up to the equivalent of 1 % NaCl and 3 % Na₂SO₄ do not affect the separation or detection when using an anion exchange column and a 100 µL sample loop.

6.3 The response of 1 mg/L of hexavalent chromium is not affected by 1 g/L of chromic ion.

6.4 Reducing species may reduce hexavalent chromium in acidic matrices. Preservation at a pH 9 to 9.5 will minimize the effect of these species.

6.5 Trace amounts of Cr are sometimes found in reagent grade salts. Since a concentrated buffer solution is used in this test method to adjust the pH of samples, reagent blanks should be analyzed to assess the potential for Cr(VI) contamination. Contamination can also come from improperly cleaned glassware or contact with caustic or acidic reagents with chromium containing stainless steel or pigmented materials.

7. Apparatus

7.1 *Ion Chromatograph*—An ion chromatograph having the following components configured as shown in Fig. 1.

7.1.1 *Pump*, capable of delivering a constant flow in the range of 1 to 5 mL/min at a pressure of 200 to 2000 psi.

7.1.2 *Injection Valve*— A high pressure, low dead volume valve that allows introduction of 50 to 250 μ L of sample into the eluent stream at up to 2000 psi.

7.1.3 *Guard Column*— A column placed before the separator column to protect the separator column from fouling by particles or strongly absorbed organic constituents.

7.1.4 *Analytical Column*—A liquid chromatographic column packed with a polymeric anion exchange resin capable of separating chromate from other anions in a sample containing high total dissolved solids (for example 3 % Na_2SO_4).

7.1.5 *Reagent Delivery Module*—A device capable of delivering 0 to 2 mL/min of reagent against a backpressure of up to 60 psi.

7.1.6 *Mixing Tee and Reaction Coil*—A device capable of mixing two flowing streams providing a sufficient reaction time for post column reaction with minimal band spreading.

7.1.7 *Detector*—A low-volume, flow-through UV-visible absorbance detector with a non-metallic flow path. The recommended detection wavelength for hexavalent chromium is 530 nm.

7.2 *Recorder, Integrator, Computer*—A device compatible with detector output, capable of recording detector response as a function of time for the purpose of measuring peak height or area.

7.3 *Eluent Reservoir*— A container suitable for storing eluent.

7.4 *Syringe*—A syringe equipped with a male luer type fitting and a capacity of at least 1 mL.

7.5 *Summary of Column Requirements* :

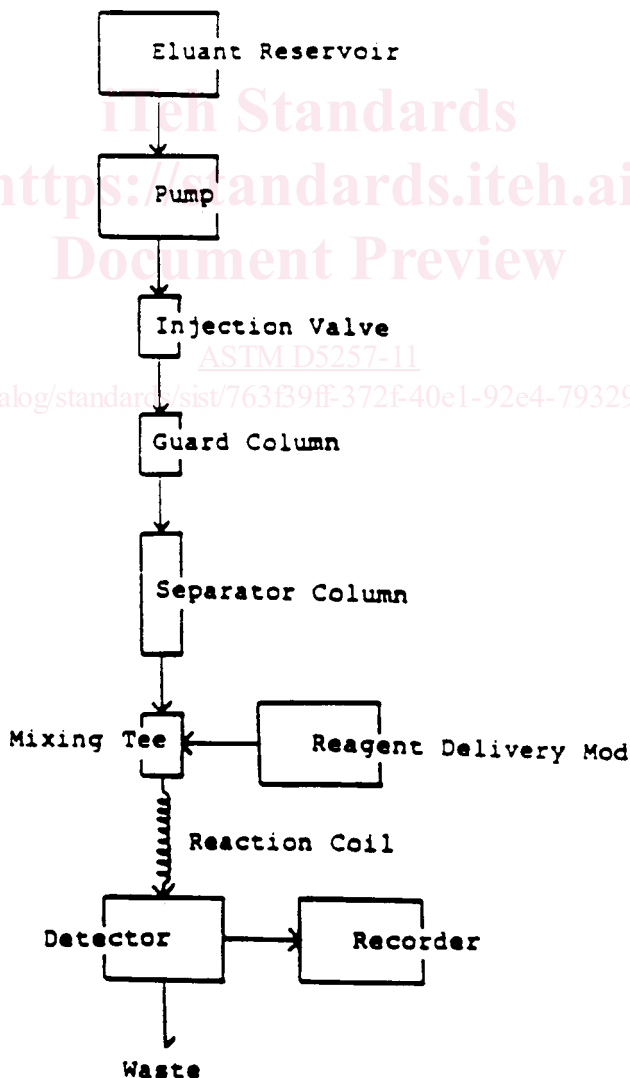

FIG. 1 Diagram of an Ion Chromatograph Using Post-Column Reagent Addition and Photometric Detection

7.5.1 *Guard Column*—A short liquid chromatographic column capable of removing organics from the injected sample so as to minimize organic fouling of the separator column.

7.5.2 *Analytical Column*—An anion exchange column capable of providing suitable retention and chromatographic efficiency for chromate ion even in the presence of high amounts of dissolved solids that can occur in wastewater samples. Note that high capacity columns will tolerate higher dissolved solids before becoming overloaded. See Section 13 for details of the columns used in the collaborative test of this test method.

8. Reagents

8.1 *Purity of Reagents*—Reagent grade chemicals shall be used in all tests. Unless otherwise indicated, it is intended that all reagents shall conform to the specifications of the Committee on Analytical Reagents of the American Chemical Society where such specifications are available.⁴ Other grades may be used, provided it is first ascertained that the reagent is of sufficiently high purity to permit its use without lessening the accuracy of the determination.

8.2 *Purity of Water*— Unless otherwise indicated, references to water shall be understood to mean reagent water conforming to Specification D1193, Type I. Other reagent water types may be used provided it is first ascertained that the water is of sufficiently high purity to permit its use without adversely affecting the bias and precision of the test method. Type II water was specified at the time of round robin testing of this test method.

8.3 *Chromium Solution, Stock (1000 mg Cr/L)*—Dissolve 0.2828 g of potassium dichromate ($K_2Cr_2O_7$ that has been dried at 105°C for 1 h) in water. Add 0.1 mL of eluanteluent concentrate (8.6) to ensure analyte stability. Dilute to 100 mL in a volumetric flask—) to ensure analyte stability. Dilute to 100 mL in a volumetric flask. Alternatively, certified chromium stock solutions are commercially available through chemical supply vendors and may be used.

8.4 *Chromium Solution, Standard (1000 µg Cr/L)*—Pipet 1.00 mL of chromium stock solution (see 8.3) and 1 mL of eluanteluent concentrate into a 1 L volumetric flask. Dilute to volume with water.

8.5 *Reagent Blank*— Add 1 mL of eluanteluent concentrate (8.6) to a 1 L flask and dilute to volume with the water used to prepare the chromium standards.

8.6 *Eluant Concentrate* (2.5 M $(NH_4)_2SO_4$, 1.0 M NH_4OH)—Dissolve 330 g of ammonium sulfate $(NH_4)_2SO_4$ in about 500 mL of water. Add 65 mL of concentrated ammonium hydroxide (NH_4OH to sp gr 0.90). Mix well and dilute to 1 L in a volumetric flask.

8.7 *Eluanteluent*—Two different analytical anion exchange columns proved satisfactory in the collaborative test that is summarized in Section 13. Accordingly, the eluanteluent appropriate for each column is described in 8.7.1 and 8.7.2. Eluantseluent should be filtered through a 0.45-µm filter and degassed.

8.7.1 *Eluanteluent for IonPac AS7 Column* (0.250 M $(NH_4)_2SO_4$, 0.1 M NH_4OH)—Add 100 mL of eluanteluent concentrate (8.6) to a 1 L volumetric flask and dilute to volume with water.

8.7.2 *Eluanteluent for IC Pac Anion HC Column* (0.025 M $(NH_4)_2SO_4$, 0.01 M NH_4OH)—Add 10 mL of eluanteluent concentrate (8.6) to a 1 L volumetric flask and dilute to volume with water.

8.8 *Diphenylcarbohydrazide Reagent*—Dissolve 0.5 g of 1,5-diphenylcarbohydrazide in 100 mL of reagent grade methanol. Add to about 500 mL of water containing 28 mL of concentrated sulfuric acid. Dilute with water, while stirring, to 1 L in a volumetric flask. Filter and degas if necessary to ensure reliable delivery.

9. Sampling

9.1 Collect the sample in accordance with the applicable ASTM Standards as follows: Practice D1066, Specification D1192, or Practices D3370.

9.2 Filter samples and adjust pH immediately upon sampling to minimize any interconversion between Cr III and Cr VI species. Filter the sample through a 0.45 µm filter. Collect the filtrate and adjust its pH to 9 to 9.5 using the eluanteluent concentrate (see 8.6). Ship and store samples at 4°C. Bring to ambient temperature prior to analysis. Analyze this stabilized filtrate within 24 h. Adjust final calculations to account for sample dilution.—) Ship and store samples at <6°C. Bring to ambient temperature prior to analysis. The sample should be analyzed within 28 days as long as the pH is above 9.0. Adjust final calculations to account for sample dilution. The holding time is based on changes to US EPA 40 CFR 136 part II, table II

10. Calibration

10.1 Prepare at least three levels of standards for each decade of the concentration range of interest. For standards of 1 to 1000 µg/L, prepare by diluting measured volumes of the standard chromium solution (see 8.4) with water in separate volumetric flasks.

10.2 Determine the chromium response for each of the standards and blank using the procedure defined in Section 11.

10.3 Prepare a calibration curve by using a linear plot of the peak height or area as a function of standard concentration. Do not force the calibration curve through zero. The response of the reagent blank should be less than 0.1 µg/L hexavalent chromium.

10.4 Prepare a new calibration curve when new reagents are made or the hardware is altered.

⁴ “Reagent Chemicals American Chemical Society Specifications” Am. Chemical Soc., Washington, DC. For suggestions on the testing of reagents not listed by the American Chemical Society, see “Analar Standards for Laboratory Chemicals,” BDH Ltd., Poole, Dorset, U.K., and the “United States Pharmacopeia.”