



## Standard Specification for Mechanical Seals for Shipboard Pump Applications<sup>1</sup>

This standard is issued under the fixed designation F1511; the number immediately following the designation indicates the year of original adoption or, in the case of revision, the year of last revision. A number in parentheses indicates the year of last reapproval. A superscript epsilon ( $\epsilon$ ) indicates an editorial change since the last revision or reapproval.

### 1. Scope

- 1.1 This specification covers mechanical end-face seals for centrifugal and positive displacement pumps for shipboard use.
- 1.2 The following types of seals are not included in this specification: lip seals, oil seals, circumferential seals, or labyrinth seals.
- 1.3 The values stated in inch-pound units are to be regarded as standard. The values given in parentheses are mathematical conversions to SI units that are provided for information only and are not considered standard. A companion hard metric standard is in the process of preparation.
- 1.4 Special requirements for U.S. Navy Shipboard Pump Applications are included in Supplement S1.

### 2. Referenced Documents

#### 2.1 ASTM Standards:<sup>2</sup>

- A108 Specification for Steel Bar, Carbon and Alloy, Cold-Finished
- A182/A182M Specification for Forged or Rolled Alloy and Stainless Steel Pipe Flanges, Forged Fittings, and Valves and Parts for High-Temperature Service
- A240/A240M Specification for Chromium and Chromium-Nickel Stainless Steel Plate, Sheet, and Strip for Pressure Vessels and for General Applications
- A276 Specification for Stainless Steel Bars and Shapes
- A313/A313M Specification for Stainless Steel Spring Wire
- A351/A351M Specification for Castings, Austenitic, for Pressure-Containing Parts
- A436 Specification for Austenitic Gray Iron Castings
- A494/A494M Specification for Castings, Nickel and Nickel Alloy
- A564/A564M Specification for Hot-Rolled and Cold-Finished Age-Hardening Stainless Steel Bars and Shapes
- A579/A579M Specification for Superstrength Alloy Steel Forgings
- A693 Specification for Precipitation-Hardening Stainless and Heat-Resisting Steel Plate, Sheet, and Strip
- A744/A744M Specification for Castings, Iron-Chromium-Nickel, Corrosion Resistant, for Severe Service
- B62 Specification for Composition Bronze or Ounce Metal Castings
- B127 Specification for Nickel-Copper Alloy (UNS N04400) Plate, Sheet, and Strip
- B164 Specification for Nickel-Copper Alloy Rod, Bar, and Wire
- B166 Specification for Nickel-Chromium-Iron Alloys (UNS N06600, N06601, N06603, N06690, N06693, N06025, N06045, and N06696) and Nickel-Chromium-Cobalt-Molybdenum Alloy (UNS N06617) Rod, Bar, and Wire
- B168 Specification for Nickel-Chromium-Iron Alloys (UNS N06600, N06601, N06603, N06690, N06693, N06025, N06045, and N06696) and Nickel-Chromium-Cobalt-Molybdenum Alloy (UNS N06617) Plate, Sheet, and Strip
- B271 Specification for Copper-Base Alloy Centrifugal Castings
- B333 Specification for Nickel-Molybdenum Alloy Plate, Sheet, and Strip
- B335 Specification for Nickel-Molybdenum Alloy Rod
- B338 Specification for Seamless and Welded Titanium and Titanium Alloy Tubes for Condensers and Heat Exchangers
- B348 Specification for Titanium and Titanium Alloy Bars and Billets
- B367 Specification for Titanium and Titanium Alloy Castings
- B443 Specification for Nickel-Chromium-Molybdenum-Columbium Alloy (UNS N06625) and Nickel-Chromium-Molybdenum-Silicon Alloy (UNS N06219) Plate, Sheet, and Strip

<sup>1</sup> This specification is under the jurisdiction of ASTM Committee F25 on Ships and Marine Technology and is the direct responsibility of Subcommittee F25.11 on Machinery and Piping Systems.

Current edition approved ~~May~~ April 1, 2009-2011. Published ~~June~~ April 2011. Originally approved in 1994. Last previous edition approved in 2007-2009 as F1511 – 079. DOI: ~~10.1520/F1511-09~~ 10.1520/F1511-11.

<sup>2</sup> For referenced ASTM standards, visit the ASTM website, www.astm.org, or contact ASTM Customer Service at service@astm.org. For Annual Book of ASTM Standards volume information, refer to the standard's Document Summary page on the ASTM website.

- B446 Specification for Nickel-Chromium-Molybdenum-Columbium Alloy (UNS N06625), Nickel-Chromium-Molybdenum-Silicon Alloy (UNS N06219), and Nickel-Chromium-Molybdenum-Tungsten Alloy (UNS N06650) Rod and Bar
- B472 Specification for Nickel Alloy Billets and Bars for Reforging
- B473 Specification for UNS N08020, UNS N08024, and UNS N08026 Nickel Alloy Bar and Wire
- B505/B505M Specification for Copper Alloy Continuous Castings
- B584 Specification for Copper Alloy Sand Castings for General Applications
- B637 Specification for Precipitation-Hardening Nickel Alloy Bars, Forgings, and Forging Stock for High-Temperature Service
- B670 Specification for Precipitation-Hardening Nickel Alloy (UNS N07718) Plate, Sheet, and Strip for High-Temperature Service
- D1141 Practice for the Preparation of Substitute Ocean Water
- D1418 Practice for Rubber and Rubber Latices Nomenclature
- D3294 Specification for Polytetrafluoroethylene (PTFE) Resin Molded Sheet and Molded Basic Shapes
- D3951 Practice for Commercial Packaging
- 2.2 *ASQ Standards:*<sup>3</sup>
- ASQC Z1.4 American Society of Quality, Quality Conformance Inspection
- 2.3 *ANSI Standards:*<sup>4</sup>
- ANSI Y14.1 Drawing Sheet Size and Format
- ANSI Y14.2 Line Convention and Lettering
- ANSI Y14.3 Multi and Sectional View Drawings
- ANSI Y14.5 Dimensioning and Tolerancing for Engineering Drawings
- ANSI Y14.6 Screw Thread Representation
- ANSI Y14.26.3 Computer-Aided Preparation of Production Definition Data, Terms and Definitions
- 2.4 *Military Standards:*<sup>5</sup>
- MIL-S-901 Shock Tests, H.I. (High Impact); Shipboard Machinery, Equipment & Systems, Requirements for
- MIL-P-16789 Packaging of Pumps, Including Prime Movers and Associated Repair Parts
- MIL-STD-167-1 Environmental Vibration Testing
- 2.5 *ISO Standard:*<sup>4</sup>
- ISO 9001 Quality Systems—Model for Quality Assurance in Design/Development, Production, Installation, and Service
- 2.6 *SAE Standards:*<sup>6</sup>
- AMS 7259 Rings, Sealing, Fluorocarbon (FKM) Rubber High-Temperature—Fluid Resistant Low Compression Set 85 to 95
- AMS 7276 Rings, Sealing, Fluorocarbon (FKM) Rubber High-Temperature—Fluid Resistant Low Compression Set 70 to 80
- AMS 3216 Fluorocarbon (FKM) Rubber, High-Temperature—Fluid Resistant, Low Compression, Set 70 to 80
- AMS 3218 Fluorocarbon (FKM) Rubber, High-Temperature—Fluid Resistant, Low Compression, Set 85 to 95
- J1926-1 Standard Dimensions for Gasket Seal Straight Thread Tube Fitting
- 2.7 *Other Document:* <https://standardsiteh.ai/catalog/standards/sist/5c8af26c-b204-44cd-81dc-a1e899005642/astm-f1511-11>
- DS56I Metals and Alloys in the Unified Numbering System

### 3. Terminology

- 3.1 Refer to Annex A1 for terminology relating to mechanical seals.

### 4. Classification of Seal Arrangements

- 4.1 For this specification, mechanical seals shall be classified by type, grade, and class. The categories are divided by application arrangement in the equipment in which it is installed:
- 4.1.1 Type A—Inside Single Mounted Seals
  - 4.1.2 Type B—Outside Single Mounted Seals
  - 4.1.3 Type C—Double Seals
  - 4.1.4 Type D—Tandem Seals
  - 4.1.5 Type E—Gas Seals
  - 4.1.6 Type F—Special Arrangements/Applications Vacuum or Gas Seal
  - 4.1.7 Grade 1—Basic End Face Seal
  - 4.1.8 Grade 2—Cartridge Seal
  - 4.1.9 Grade 3—Split Seal
  - 4.1.10 Class 0—Nonsplit Seal Assembly

<sup>3</sup> Available from American Society for Quality (ASQ), 600 N. Plankinton Ave., Milwaukee, WI 53203, <http://www.asq.org>.

<sup>4</sup> Available from American National Standards Institute (ANSI), 25 W. 43rd St., 4th Floor, New York, NY 10036, <http://www.ansi.org>.

<sup>5</sup> Available from Standardization Documents Order Desk, Bldg. 4, Section D, 700 Robbins Ave., Philadelphia, PA 19111-5098, Attn: NPODS.

<sup>6</sup> Available from Society of Automotive Engineers (SAE), 400 Commonwealth Dr., Warrendale, PA 15096-0001, <http://www.sae.org>.

- 4.1.11 Class 1—Partial Split Seal Assembly, Solid Gland
- 4.1.12 Class 2—Partial Split Seal Assembly, Split Gland
- 4.1.13 Class 3—Fully Split Seal Assembly, Solid Gland
- 4.1.14 Class 4—Fully Split Seal Assembly, Split Gland

4.2 Figs. 1-6 give general orientation information for various types of seals. The specific design of seal shown is not limited to that particular application.

**5. Ordering Information**

5.1 The purchaser (buyer) shall provide the manufacturer with all of the pertinent application data shown in Figs. 7-9. If special operating conditions exist that are not shown in the checklist, they shall also be described.

**6. Material**

6.1 Mechanical seals shall be constructed of materials selected from Tables 1-3 after reviewing temperature, pressure/velocity (PV), and corrosion resistance requirements for all parts for each application.

6.2 *Metal Components:*

6.2.1 Mechanical seal metal parts in contact with the pumped liquid shall be compatible with their environment.

6.2.2 Table 1 identifies metal component compatibility.

iTeh Standards  
(<https://standards.itih.ai>)  
Document Preview

ASTM F1511-11

<https://standards.itih.ai/catalog/standards/sist/5c8af26c-b204-44cd-81dc-a1e899005642/astm-f1511-11>

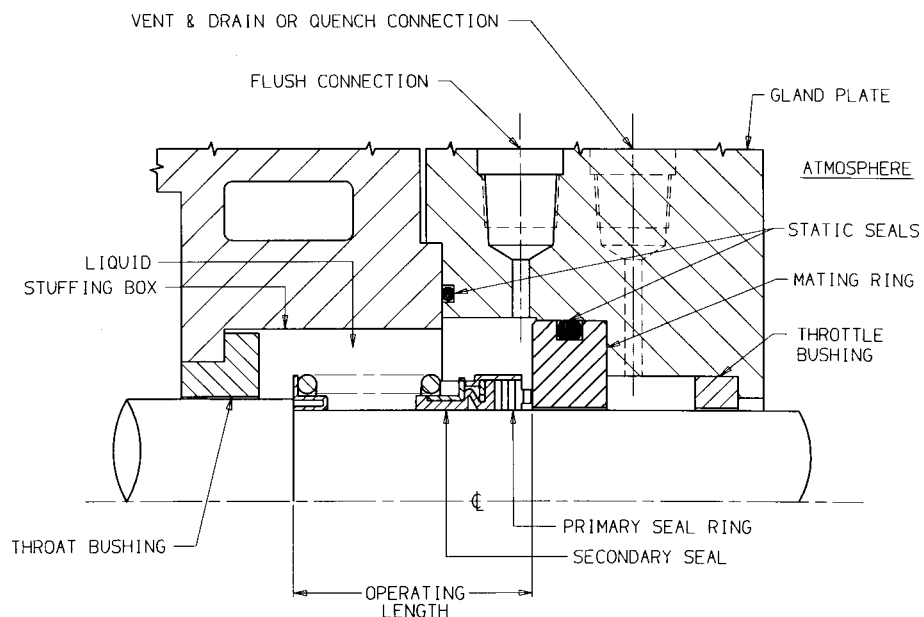

**FIG. 1 Single Seal—Inside Bellows Secondary Seal, Classification Type A Grade 1**

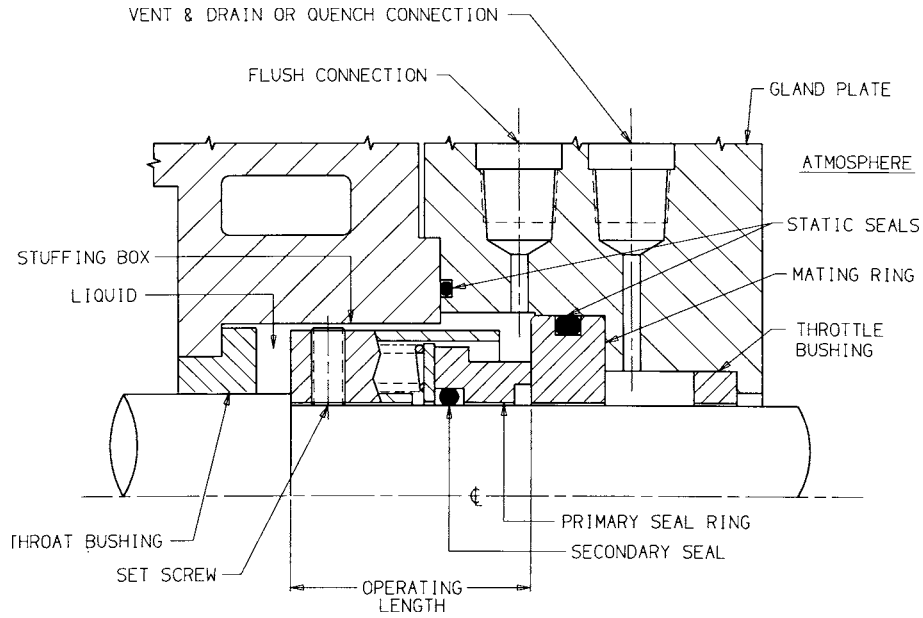

FIG. 2 Single Seal—Inside O-Ring Secondary Seal, Classification Type A Grade 1

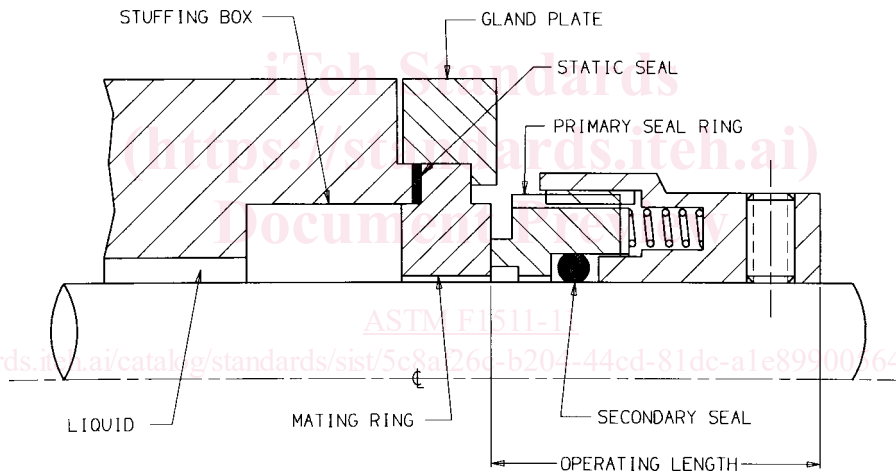

FIG. 3 Single Seal—Outside Mounted Classification Type B Grade 1

6.2.3 Material specifications:

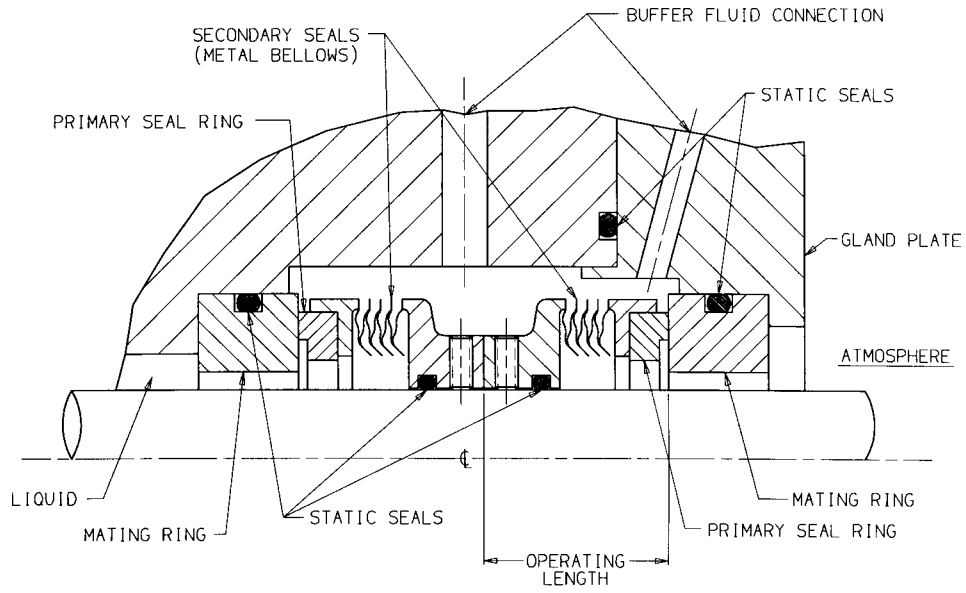

FIG. 4 Double Seals—Back to Back Classification Type C Grade 1

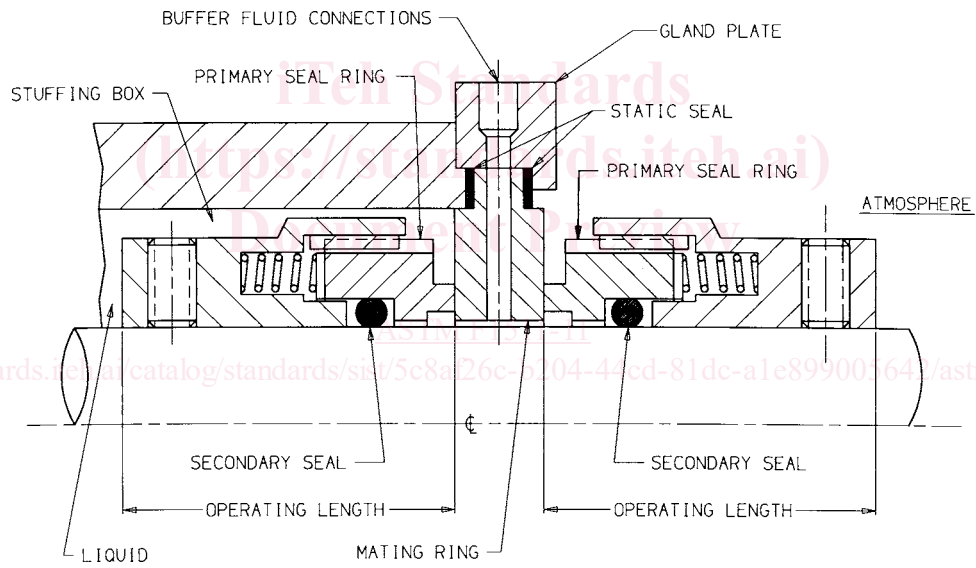

FIG. 5 Double Seals—Face to Face Classification Type C Grade 1

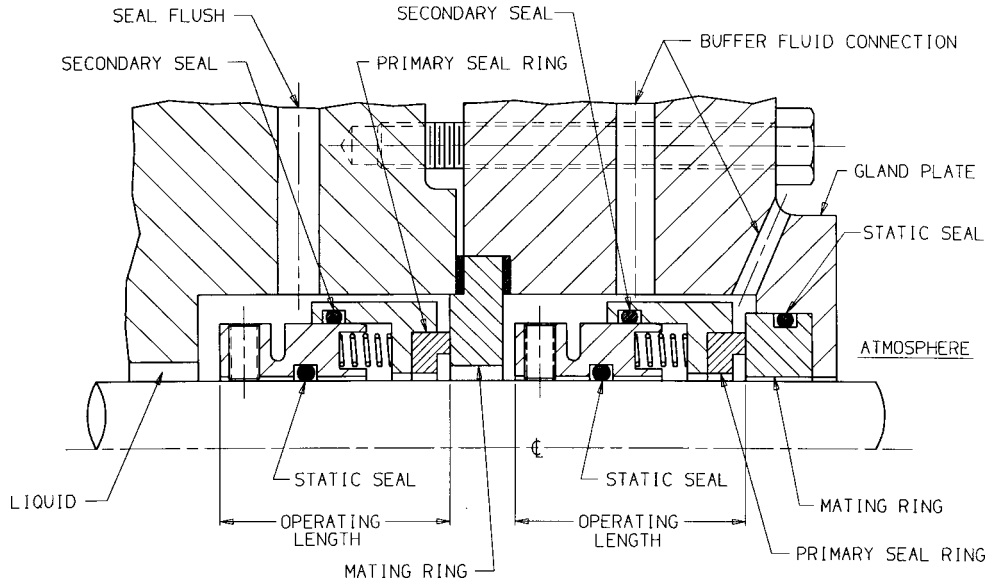

FIG. 6 Tandem Seals Classification Type D Grade 1

1.1 Seal Description

Type \_\_\_\_\_ Grade \_\_\_\_\_

1.2 Pump Description

Pump Mfg. \_\_\_\_\_ Model \_\_\_\_\_ Size \_\_\_\_\_

Pump S/N \_\_\_\_\_

Pump Type (Horizontal, Vertical, etc.) \_\_\_\_\_

No. of Stages \_\_\_\_\_

Sleeve or Shaft Mat'l \_\_\_\_\_ Casting Mat'l \_\_\_\_\_

Cooling Water Available? \_\_\_\_\_ °F \_\_\_\_\_ GPM

Stuffing Box Water Jacketed? Yes \_\_\_\_\_ No \_\_\_\_\_

Is Face of Stuffing Box Machined? Yes \_\_\_\_\_ No \_\_\_\_\_

FILL OUT STUFFING BOX DIMENSIONS SHOWN ON FIG. 8

2.1 Liquid Pumped

Fluid \_\_\_\_\_ Concentration \_\_\_\_\_ Specify for unique cargo pump fluid application

Pumping Temperature (°F) Normal \_\_\_\_\_

Max \_\_\_\_\_

Min \_\_\_\_\_

Specific Gravity at Operating Condition \_\_\_\_\_

Viscosity Range at Operating Conditions/Temp. \_\_\_\_\_ SSU

Vapor Pressure at Operating Conditions/Pressure \_\_\_\_\_ psig

Corrosion/Erosion Caused by: \_\_\_\_\_ % Solids \_\_\_\_\_

Abrasive Separator To be Supplied—Yes \_\_\_\_\_ No \_\_\_\_\_

2.2 Operating Conditions

Rated Discharge Pressure Max (psig) \_\_\_\_\_

Suction Box Pressure Range (psig) \_\_\_\_\_

Stuffing Box Pressure Range (psig) \_\_\_\_\_

Stuffing Box Temperature Max (°F) \_\_\_\_\_

Hydrostatic Test Pressure (psig) \_\_\_\_\_

Speed (rpm) \_\_\_\_\_

Direction of Rotation From Drive End CW or CCW \_\_\_\_\_

3.1 Preservation and Packaging

Special Preservation & Packaging for Storage & Shipment \_\_\_\_\_

Special Marking \_\_\_\_\_

4.1 Other Special Requirements

Seal Manufacturer's Certification of

Compliance Required—Yes \_\_\_\_\_ No \_\_\_\_\_

5.1 US Navy Application Requirements

Supplement S1, ----- Yes \_\_\_\_\_ No \_\_\_\_\_

Check applicable dimensional Table below:

Table No. S1, Standard Long Mechanical Seal \_\_\_\_\_

Table No. S2, Standard Short Mechanical Seal \_\_\_\_\_

Table No. S3, Special Cartridge Seals Grade 2 \_\_\_\_\_

Table No. S4, Special Seals Grade 1 \_\_\_\_\_

FIG. 7 Ordering Data Checklist

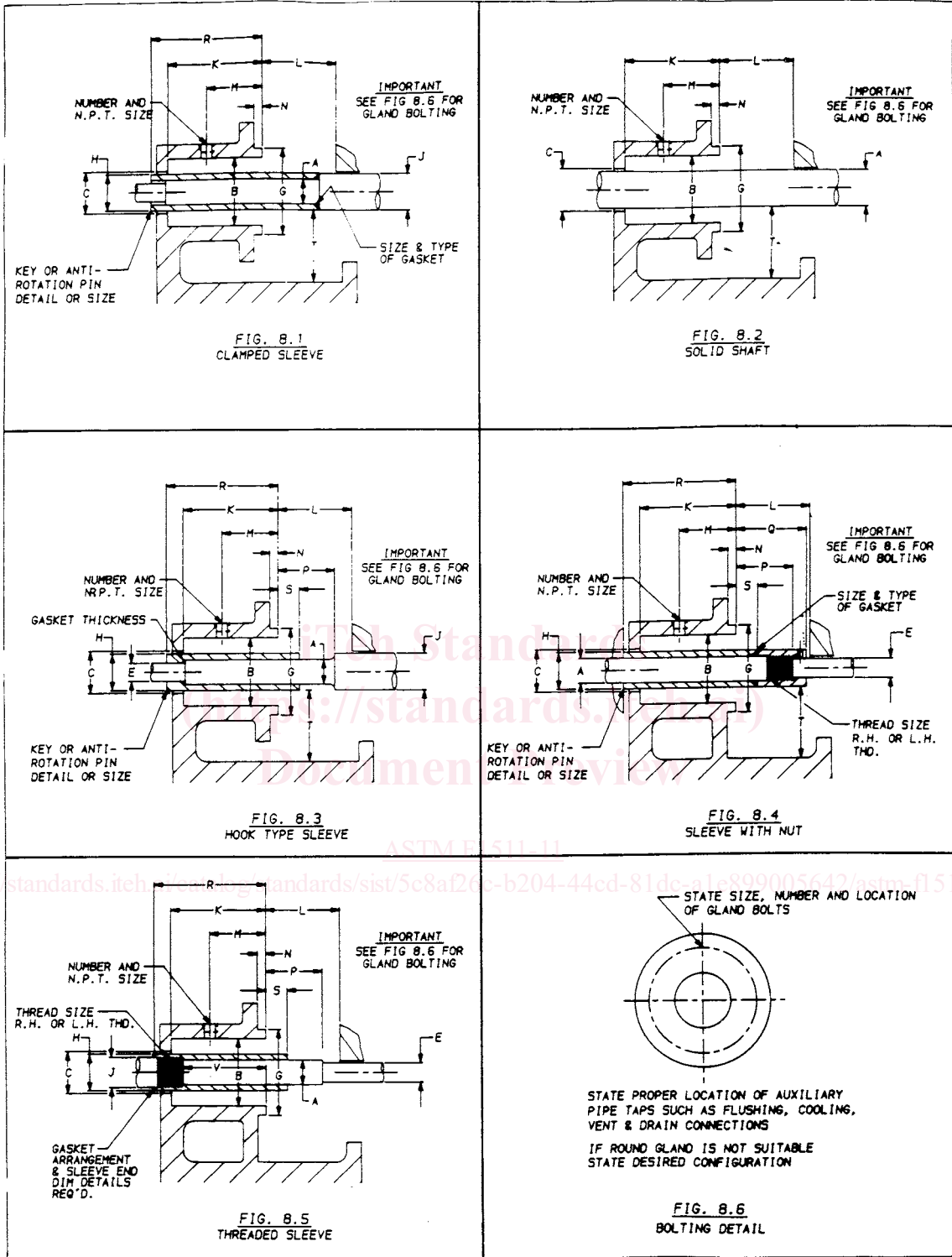

FIG. 8 Stuffing Box Arrangement

Refer to Fig. 8

A.		K.	
B.		L.	
C.		M.	
D.		N.	
E.		P.	
F.		R.	
G.		S.	
H.		T.	
J.		U.	
N.P.T. _____			
Bolt Holes or Stud Loc. _____			
Thread Size _____			
Auxiliary Pipe Tap Loc. _____			
Comments _____			

**FIG. 9 Stuffing Box Dimensions**
**TABLE 1 Metal Component Compatibility**

NOTE 1—For fluids or materials not covered here, seal selection to be mutually agreed upon by seal manufacturer, pump supplier, and end user.

NOTE 2— X = Suitable for use as seal components.

Fluid	Materials <sup>A</sup>						
	Brass	316 Stainless Steel	Ni-Cu	Alloy 20	Highly Alloyed Stainless Steel	Ni-Mo	Ni-Cr-Mo-Cb Ni-Cr-Fe
<i>Fresh Water</i>							
Deminerlized water		X		X	X	X	X
Boiler feed		X		X	X	X	X
Potable	X	X	X	X	X	X	X
<i>Salt Water</i>							
Seawater			X	X	X	X	X
Distiller brine			X	X	X	X	X
<i>Fuel Oil</i>							
Navy distillate		X	X	X	X	X	X
JP-5		X	X	X	X	X	X
Diesel		X	X	X	X	X	X
Kerosene		X	X	X	X	X	X
Crude oil		X	X	X	X	X	X
Lube oil		X	X	X	X	X	X
Sewage			X	X	X	X	X

<sup>A</sup> See Section 6 for material specifications.



**TABLE 2 Seal Face Materials**

NOTE 1—Faces for chemically active materials and special applications shall be agreed upon by seal manufacturer and end user.

Seal Face Compatibility Chart		
Primary Ring	Mating Ring	PV Limit, <sup>A</sup> lb/in. <sup>2</sup> × ft/min (MPa·m/s)
Carbon	Tungsten carbide	500 000 (17.75)
Carbon	Silicon carbide	500 000 (17.75)
Carbon	Ceramic <sup>B</sup>	100 000 (3.55)
Siliconized carbon	Tungsten carbide	350 000 (12.43)
Siliconized carbon	Silicon carbide	350 000 (12.43)
Silicon carbide	Tungsten carbide	300 000 (10.65)
Silicon carbide	Silicon carbide	350 000 (12.43)
Tungsten carbide	Tungsten carbide	120 000 <sup>C</sup> (4.26)

<sup>A</sup> Values of PV apply to aqueous solutions at 120°F (49°C). For lubricating liquids, such as oil, 60 % higher can be used. Given limits are to be used as a general guide in material selection. Values used consider a pressure drop across the seal faces as 0.5.

<sup>B</sup> Limited to chemical service requirements only.

<sup>C</sup> PV limit of 185 000 (6.57) can be used with two different grades of tungsten carbide, that is, cobalt versus nickel binders.

**TABLE 3 Elastomer Compatibility**

NOTE 1—X = Suitable for fluids within temperature range indicated.

Fluid Temp. Limits: Min Max	Nitrile-N -50°F (-46°C) +250°F (121°C)	Fluorocarbon <sup>A</sup> -25°F (-32°C) +400°F (204°C)	PTFE <sup>B</sup> -150°F (-101°C) +500°F (260°C)	Corrugated Graphite Ribbon -400°F (-46°C) +750°F (400°C)	EP -50°F (-46°C) +300°F (149°C)	Chloroprene -50°F (-46°C) +200°F (93°C)
<i>Fresh Water</i>						
Deminerlized water	X	X	X	X	X	X
Boiler feedwater	X	X	X	X	X	X
Potable water	X	X	X	X	X	X
<i>Salt Water</i>						
Seawater	X	X	X	X	X	X
Distiller brine		X	X	X	X	X
<i>Fuel and Lubricants</i>						
Navy distillate	X	X	X	X		X
JP-5	X	X	X	X		X
Bunker C	X	X	X	X		X
Diesel oil	X	X	X	X		X
Kerosene	X	X	X	X		X
Lube oil (mineral base)	X	X	X	X		X
Sewage	X	X	X	X	X	X

<sup>A</sup> Fluorocarbon shall be limited to 275°F (135°C) in water.

<sup>B</sup> Care should be used in selecting PTFE. Its use is only dictated when other elastomers are not suitable and PTFE is acceptable. PTFE is not acceptable for nuclear service, or in a radiation area. Glass-filled PTFE has a temperature range of -350°F (-212°C) to +500°F (260°C).

Material	ASTM
Copper alloy	B271, B584, B505/B505M
Bronze	B62
Alloy 20	B472 and B473 (UNS N08020, N08026)
316 stainless steel	A240/A240M, A276, and A313/A313M (UNS S316XX)
304 stainless steel	A182/A182M, A313/A313M (UNS S304XX), A351/A351M (CF3, 3A; CF8, 8A; CF8C; CF10)
Alloyed stainless steel (cast)	A744/A744M (CN-7M, CN-7MS)
17-4 PH	A564/A564M and A693 (UNS S17400)
AM 350	A579/A579M (Grade 61)
NiCu <sup>A</sup>	B164 (UNS N04400, N04405), B127, A494/A494M (Grades M35-1, M35-2, M-30H, M-25S)
NiMo	A494/A494M (Grades CW-2M, N-12 MV)
NiMo <sup>B</sup> (Alloy B)	B333 and B335 (UNS N10001, N10665, N10675)
NiCrFe <sup>C</sup> NiCrMoCo	B166, B168
NiCr	B637, B670

NiCrMoCb <sup>D</sup>	B443, B446
Steel	A108
Austenitic grey iron	A436
Titanium	B338, B348, B367
Nickel cast iron (ductile nodular or graphitic)	A436 Type 1

<sup>A</sup> Monel<sup>7</sup> or equivalent has been found satisfactory for this purpose.

<sup>B</sup> Hastelloy B or equivalent has been found satisfactory for this purpose.

<sup>C</sup> Inconel X750<sup>8</sup> or equivalent has been found satisfactory for this purpose.

<sup>D</sup> Inconel 625<sup>8</sup> or equivalent has been found satisfactory for this purpose.

6.3 *Face Materials*—Mechanical seal-wearing faces shall be selected to provide the desired performance and corrosion resistance for the specified design life of the seal.

6.3.1 Performance ranges for face combinations are listed in Table 2.

6.3.2 Face materials shall be of solid construction only; no overlays, deposited coatings, or sprayed on coatings are permitted.

6.3.3 Carbon is preferred for one of the faces unless the service is abrasive, dirty, or chemically active.

6.3.4 For special service requirements, hard on hard seal face combinations may be required. Face material combinations, such as silicon carbide versus silicon carbide, silicon carbide versus tungsten carbide, and tungsten carbide versus tungsten carbide, may be used as similar or dissimilar contacting face materials when recommended by the supplier and approved by the user.

6.4 *Face Material Specifications* :

6.4.1 *Carbon*—Suitable for service as recommended by the manufacturer. A carbon seal grade is a material having carbonaceous filler system comprised of pitch and resins, compacted and baked to a final temperature. These grades are subsequently impregnated with resin until they become impervious. All available carbons may not be suitable for a particular application. Carbons considered for use in a particular application shall be checked for suitability in accordance with the requirements of this specification.

6.4.2 *Tungsten Carbide*—6 to 10 % nickel or cobalt-bound solid tungsten carbide.

6.4.3 *Ceramic*—99.5 % minimum alumina ceramic suitable for the service as recommended by the manufacturer.

6.4.4 *Silicon Carbide*—(a) *Reaction-Bonded*—Solid fine-grained reaction-bonded silicon carbide 8 to 12 % free silicon, essentially free of carbon, impervious structure requiring no impregnant. (b) *Reaction-Bonded With Graphite*—A composite material of fine-grain reaction-bonded silicon carbide; 5 to 10 % free silicon and 10 to 30 % graphite; impervious structure requiring no impregnant. (c) *Direct Sintered*—Solid homogeneous silicon carbide essentially free of silicon and carbon, impervious structure requiring no impregnant. (d) *Direct Sintered Silicon Carbide*—Contains 10 % free graphite. (e) *Siliconized Carbon Graphite*—Approximately 0.025-in. (0.64-mm) thick conversion of silicon carbide on carbon substructure and impregnated with thermosetting resin.

6.5 *Elastomeric Materials*:

6.5.1 Special care should be given to the selection and installation of elastomeric components, such as bellows and O-rings. One of the most important considerations for elastomers is fluid compatibility. Table 3 references most shipboard applications. Consult the seal manufacturer for fluids not listed.

6.5.2 *Material Classification/Specification* :

6.5.2.1 Nitrile—Practice D1418, Class Designation NBR.

6.5.2.2 Chloroprene—Practice D1418, Class Designation CR.

6.5.2.3 Fluorocarbon—Practice D1418, Class Designation FKM.

6.5.2.4 Ethylene Propylene (EP)—Practice D1418, Class Designation EPM/EPDM.

6.5.2.5 Perfluoroelastomer—Practice D1418, Class Designation FFKM.

6.5.2.6 Polytetrafluorethylene (PTFE)—Specification D3294.

6.5.2.7 Corrugated graphite ribbon packing.

6.5.3 Ethylene propylene (EP) rubber shall not be lubricated with any petroleum base substances. Check Section 11 and Appendix X1 or manufacturer's recommendations before using any lubricant.

## 7. Performance Requirements

7.1 Seal life shall be defined in terms of the time period in which the mechanical seal functions properly under its specified service.

7.1.1 The minimum operational life of a mechanical seal shall be 16 000 statistical hours provided that the equipment is maintained and operated in accordance with the requirements of Section 8.

7.1.2 During any portion of the service life, the dynamic leakage shall not exceed five drops per minute for Class 0 seals. After initial installation, hydrostatic leakage shall be zero for a 5-min period, when the equipment is subjected to system pressure.

7.1.3 All split mechanical seals, Classes 1 through 4, may experience higher leakage rates than Class 0, solid mechanical seals. A leakage rate of five drops per minute shall be acceptable after completion of the manufacturer's recommended break-in period.

<sup>7</sup> The term "Monel" and the Monel logo are trademarks of the Special Metals Corporation, Huntington, WV, USA.

<sup>8</sup> The term "Inconel" and the Inconel logo are trademarks of the Special Metals Corporation, Huntington, WV, USA.

7.1.4 In special applications of extreme environmental parameters, such as high temperature with limited cooling, high pressure/velocity, extreme abrasion, unusual equipment vibration, shaft end-play, or run-out, the pump and seal manufacturers shall agree upon the best achievable minimum operating life requirements and leakage performance.

7.1.5 Double or special seal arrangements may be required in applications in which zero product leakage to the environment is required such as hazardous fluids, fuel oil, acids, chemicals, and sewage. Consult the seal manufacturer for recommendations.

## 8. Design Requirements Design Requirements

### 8.1 Installation Arrangements:

8.1.1 Type A mechanical seals shall be provided unless otherwise specified.

8.1.2 Tandem or double mechanical seals may be installed in special applications in which it is determined that a buffer fluid system is required for lubrication, containment, or safety.

8.2 Finish and tolerance requirements for primary seal ring and mating ring surface flatness of Class 0 mechanical seals shall be three light bands or better as measured under a monochromatic, helium light source.

### 8.3 Requirements for Installation of Classes 1 Through 4 Split Mechanical Seals:

8.3.1 Classes 1 through 4, split mechanical seals, may be furnished for shaft/sleeve diameters of 1½ in. (38.1 mm) and above.

8.3.2 For split mechanical seal installations, a minimum of 3 in. (76.2 mm) of axial space, measured from the stuffing box face to the first obstruction, shall be provided for Classes 2 and 4 seals. Additional space, at least equal to the gland thickness, may be required for Classes 1 and 3 seals.

8.3.3 Classes 1 through 4, split mechanical seals, shall be designed to operate under a minimum reverse differential pressure condition of 15-in. Hg (50.8 kPa).

8.4 The requirement for a balanced or unbalanced seal will vary dependent upon the combination of various design and performance factors. Balanced seals shall normally be supplied for pressures greater than 150 psi (1.03 MPa) unless the seal manufacturer provides alternative recommendations for specific applications. Selection of a balanced or unbalanced seal design must satisfy the performance requirements of Section 7.

8.5 The mechanical seal shall be designed to operate satisfactorily under the following:

8.5.1 Shaft sleeve surface finish for pusher-type seals shall be 32 rms (0.80 µm) maximum. Shaft sleeve surface finish for nonpusher seals shall be 64 rms (1.60 µm) maximum.

8.5.2 Shaft radial run-out 0.010 in. (0.25 mm) TIR maximum.

8.5.3 Shaft end-play maximum ±0.015 in. (0.38 mm).

8.5.4 Concentricity of stuffing box bore to shaft axis 0.005 in. (0.13 mm) TIR maximum. Gland plate design must accommodate eccentricity stated herein.

8.5.5 Perpendicularity of stuffing box face to shaft axis 0.003 in. (0.08 mm) TIR maximum.

8.6 *Environmental Controls*—Environmental control considerations, such as flushing, cooling, heating, and quenching shall be specified by the seal manufacturer.

## 9. Quality Assurance Provisions

9.1 *Quality Systems*—Mechanical seals shall be supplied in accordance with ISO 9001.

9.2 *Responsibility for Inspection*—Unless otherwise specified, the manufacturer is responsible for the performance of all inspection requirements. The manufacturer may use his own or any other facilities suitable for inspection. The purchaser (buyer) reserves the right to perform any of the inspections set forth in the specification where such inspections are deemed necessary to assure supplies and services conform to prescribed requirements.

9.3 *Material Inspection*—The manufacturer shall be responsible for ensuring that materials used are manufactured, examined, and tested in accordance with the specifications and standards as applicable.

9.4 *Classification of Inspections*—The inspection requirements specified herein shall be classified as follows:

9.4.1 *Quality Conformance Inspection.*

9.4.2 *Inspection of Packaging.*

9.5 *Quality Conformance Inspection*—All seal components shall be inspected in accordance with ASQC Z1.4 listing critical, major, and minor characteristics and type of inspection equipment used to determine said characteristics.

9.5.1 *Acceptable Quality Level for Characteristics* —The acceptable quality levels for characteristics, as per ASQC Z1.4, shall be as follows:

9.5.1.1 Critical—1.5 AQL.

9.5.1.2 Major—2.5 AQL.

9.5.1.3 Minor—4.0 AQL.

9.5.2 *Tests*—All tests shall be performed in accordance with ASTM, ASME, or manufacturer's standards as specified.

9.5.3 *Test Data*—All test data shall remain on file at the manufacturer's facility for review by buyer upon request. It shall be retained in the manufacturer's files for at least three years.

9.6 *Inspection of Packaging:*

9.6.1 *Unit of Product*—For the purpose of inspection, a completed package prepared for shipment shall be considered as a unit of product.