



SLOVENSKI STANDARD
oSIST prEN 16916:2023
01-september-2023

Nadomešča:
SIST-TS CEN/TS 16916:2016

Snovi iz izrabljenih avtomobilskih gum - Določanje specifičnih zahtev za vzorčenje in ugotavljanje deleža vlage z uporabo sušilnika

Materials obtained from End of Life Tyres - Determination of specific requirements for sampling and determination of moisture content using the oven-dry method

Materialien aus Altreifen - Bestimmung der spezifischen Anforderungen für die Probenahme und Bestimmung des Feuchtegehaltes aus dem Ofen-Trockenverfahren

Matériaux obtenus à partir de pneus usagés non réutilisables (PUNR) - Détermination des exigences spécifiques relatives à l'échantillonnage et détermination de la teneur en humidité selon la méthode de séchage à l'étuve

Ta slovenski standard je istoveten z: prEN 16916

ICS:

13.030.50	Recikliranje	Recycling
83.160.01	Avtomobilske pnevmatike na splošno	Tyres in general

oSIST prEN 16916:2023 **en,fr,de**

EUROPEAN STANDARD
NORME EUROPÉENNE
EUROPÄISCHE NORM

DRAFT
prEN 16916

July 2023

ICS 13.030.50; 83.160.01

Will supersede CEN/TS 16916:2016

English Version

Materials obtained from End of Life Tyres - Determination of specific requirements for sampling and determination of moisture content using the oven-dry method

Materialien aus Altreifen - Bestimmung der spezifischen Anforderungen für die Probenahme und Bestimmung des Feuchtegehaltes aus dem Ofen-Trockenverfahren

This draft European Standard is submitted to CEN members for enquiry. It has been drawn up by the Technical Committee CEN/TC 366.

If this draft becomes a European Standard, CEN members are bound to comply with the CEN/CENELEC Internal Regulations which stipulate the conditions for giving this European Standard the status of a national standard without any alteration.

This draft European Standard was established by CEN in three official versions (English, French, German). A version in any other language made by translation under the responsibility of a CEN member into its own language and notified to the CEN-CENELEC Management Centre has the same status as the official versions.

CEN members are the national standards bodies of Austria, Belgium, Bulgaria, Croatia, Cyprus, Czech Republic, Denmark, Estonia, Finland, France, Germany, Greece, Hungary, Iceland, Ireland, Italy, Latvia, Lithuania, Luxembourg, Malta, Netherlands, Norway, Poland, Portugal, Republic of North Macedonia, Romania, Serbia, Slovakia, Slovenia, Spain, Sweden, Switzerland, Türkiye and United Kingdom.

Recipients of this draft are invited to submit, with their comments, notification of any relevant patent rights of which they are aware and to provide supporting documentation.

Warning : This document is not a European Standard. It is distributed for review and comments. It is subject to change without notice and shall not be referred to as a European Standard.



EUROPEAN COMMITTEE FOR STANDARDIZATION
COMITÉ EUROPÉEN DE NORMALISATION
EUROPÄISCHES KOMITEE FÜR NORMUNG

CEN-CENELEC Management Centre: Rue de la Science 23, B-1040 Brussels

Contents	Page
European foreword.....	3
1 Scope	4
2 Normative references	4
3 Terms and definitions	4
4 Principle	4
5 Apparatus	4
6 Preparation of the sampling plan and laboratory sample	4
6.1 Principles of sampling	4
6.1.1 General	4
6.1.2 Sampling plan	5
6.2 Sampling point and apparatus	5
6.2.1 Sampling point for stocked materials	5
6.2.2 Sampling point for production samples	6
6.3 Determination of lot size	7
6.3.1 Lot size for production	7
6.3.2 Lot size of stocked material	7
6.4 Size of a sample increment	7
6.5 Number of increments	7
6.5.1 Number of increments from production process	7
6.5.2 Number of increments from stocked materials in big bags	8
6.6 Storage and transport of laboratory sample(s)	8
7 Procedure	8
7.1 Reference method	8
8 Calculation	10
8.1 Moisture content - reference method	10
9 Test report	10
Bibliography	11

European foreword

This document (prEN 16916:2023) has been prepared by Technical Committee CEN/TC 366 “Materials obtained from End-of-Life Tyres (ELT)”, the secretariat of which is held by UNI.

This document is currently submitted to the CEN Enquiry.

This document will supersede CEN/TS 16916:2016.

iTeh STANDARD PREVIEW
(standards.iteh.ai)

[oSIST prEN 16916:2023](https://standards.iteh.ai/catalog/standards/sist/a37d7a98-062a-4089-b98a-b0d2d36ffa29/osist-pren-16916-2023)

<https://standards.iteh.ai/catalog/standards/sist/a37d7a98-062a-4089-b98a-b0d2d36ffa29/osist-pren-16916-2023>

1 Scope

This document specifies a method for determining the total moisture content of materials obtained from End of Life Tyres (ELT) by drying samples in an oven. The method is applicable to chips, granulates, powders and textile derived from the treatment of End of Life Tyres.

This document is not intended for the determination of moisture content in steel wires.

2 Normative references

The following documents are referred to in the text in such a way that some or all of their content constitutes requirements of this document. For dated references, only the edition cited applies. For undated references, the latest edition of the referenced document (including any amendments) applies.

CEN/TS 14243:2010, *Materials produced from end of life tyres - Specification of categories based on their dimension(s) and impurities and methods for determining their dimension(s) and impurities*

3 Terms and definitions

For the purposes of this document, the terms and definitions given in CEN/TS 14243:2010 apply.

4 Principle

The sample of material is dried at a temperature of 105 °C in air atmosphere until constant mass is reached. The percentage of moisture is calculated from the loss in mass of the sample. The method includes a procedure for the correction of buoyancy effects.

5 Apparatus

5.1 Drying oven, capable of being controlled at (105 ± 2) °C (see declaration of the manufacturer) and in which the air atmosphere changes between three and five times per hour.

The air velocity shall be such that the sample particles are not dislodged from their dish or tray (5.2).

5.2 Dishes or trays of non-corrodible and heat-resistant material and of such dimensions that they are able to hold the total sample in the proportion of about 1 g of sample per 100 mm² of surface area of the dish or tray respectively or about 0,5 g per 100 mm² for textile samples.

The surface of the dish or tray shall be such that the possibility to adsorption/absorption is minimized (very clean and even surface).

5.3 Balance, capable of weighing the sample and dish or tray (5.2), as received, to the nearest 0,1 g.

6 Preparation of the sampling plan and laboratory sample

6.1 Principles of sampling

6.1.1 General

The main principle of sampling is to obtain a representative sample(s) from a lot of material from which the moisture content shall be determined.

The objective of this procedure is to take samples in a way that is truly representative of the moisture content of the material produced. There are two alternatives. The first alternative is to measure the moisture content of a production sample, in a point as close as possible to the entrance point in the big bag. The second alternative is to measure the moisture content from stored material.

It is important to handle as little as possible the samples, as this manipulation can strongly affect the moisture content of the sample.

6.1.2 Sampling plan

A written sampling plan shall be prepared before samples are taken according to 6.2 to 6.6. The number of increments shall be not less than the minimum number of increments specified in 6.5.

The sampling scheme shall contain, at least, the following information:

- a) the name of the sampler, the place where the sample was taken and the date when it was taken;
- b) a full identification of the laboratory sample (reference);
- c) a full identification of the big-bag from which the sample was taken;
- d) the type of storage condition (outdoor or indoor);
- e) the mass of the laboratory sample (g);
- f) the name and the volume of the sampling tool (ml);
- g) the number and position of the primary portions within the big-bag;
- h) the type of ELTs specified in the test programme;
- i) a reference to this document;
- j) the report on all the operating conditions not specified in this document, or any optional operations;
- k) the report on any possible incidents that might have affected the representative nature of the sample.

6.2 Sampling point and apparatus

6.2.1 Sampling point for stocked materials

To give a laboratory sample having a mass of not less than 500 g, six sampling points for the collection of sample increments shall be chosen for each material to be monitored.

Sampling shall be carried out taking the primary increments from different heights of a big bag. At least three increments shall be taken at different heights as specified in 6.5:

- P1: At the top (approximately 20 cm from the surface);
- P2: In the middle;
- P3: At the bottom of the big-bag (approximately 20 cm from the bottom).

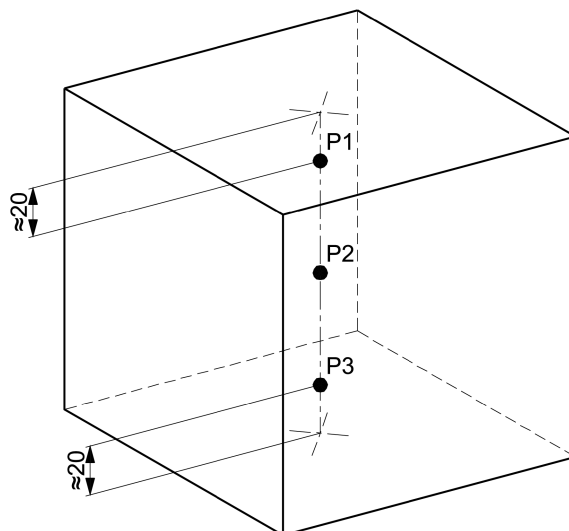

Figure 1 — Position of increments for three portions

If it is not possible to take samples in the centre axis of big-bag (see Figure 1) then six increments shall be taken on two opposite sides of the big bag at different heights (see Figure 2).

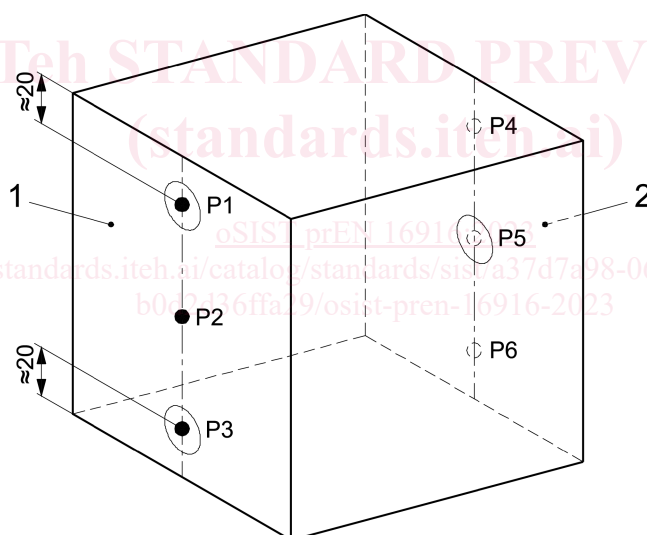

Figure 2 — Position of increments for six portions

Two apparatus for taking samples are shown in 6.5.2 (taking of an increment by the top of the sample and taking of an increment by the side of the big bag).

The sampler can choose the most appropriate tool provided that the tool chosen is specified in the sampling scheme.

- 1) mix the increments in a pan to make up the laboratory sample;
- 2) weigh the laboratory sample.

6.2.2 Sampling point for production samples

A fixed sampling point for the collection of sample increments shall be chosen for each material to be monitored. The best sampling point for moisture determination on a production sample is the sealing

closure of the big bag when the moisture content of the sample due to the production conditions shall not change.

Sampling shall be carried out using a sample box or other suitable equipment. The sampling box is passed through the stream of falling material so that it uniformly cuts the full flow of falling material. The box shall be large enough so that it does not become overloaded. Automatic systems fulfilling these criteria may also be used.

6.3 Determination of lot size

6.3.1 Lot size for production

The lot size shall be defined by the producer in accordance with requested specifications and is a fixed quantity for which a characteristic shall be determined. The lot size (Mlot) may be defined by the producer as:

- a fixed quantity in a production day/shift;
- a fixed quantity minimum of 20 t (10 t for powders).

The lot size should be determined based on production quality management decisions or specific customer requirements.

6.3.2 Lot size of stocked material

The lot size shall be defined by the producer or by agreement between producer and customer.

The lot size should be based on specific customer requirements.

6.4 Size of a sample increment

The sampling box shall have a capacity of not less than 2 000 cm³. Each increment should be not less than 200 cm³ and not bigger than 500 cm³.

6.5 Number of increments

6.5.1 Number of increments from production process

The minimum number of increments to be taken from a lot depends on the nominal top size of the granulate material to be sampled. The granulate shall be assigned by the sampler to one of two groups in Table 1.

Table 1 — Classification of material according to size

Group 1	Group 2
nominal top size < 10 mm	nominal top size is between 10 mm and 20 mm

When sampling from moving material:

- Group 1: $n = 3 + 0,025 \times \text{mlot}$ size of granulates from 0,8 mm to 10 mm and powders under 0,8 mm
- Group 2: $n = 5 + 0,040 \times \text{mlot}$ size of granulates from 10 mm to 20 mm and chips considered as very large granulates

where

n is the minimum permitted number of increments rounded off to the higher nearest whole number;

mlot is the mass of the lot in tonnes.

prEN 16916:2023 (E)

Sample collection is carried out according to the sample plan and the increments are collected manually using the sampling box. Each increment is placed in a separate container. Increments shall be taken at regular intervals during the discharge of the lot in accordance with the sampling plan. The time of increment collection is recorded in the sampling plan. At the end of this process, all the increments corresponding to the lot are put together to create the combined sample(s) which are sent to the laboratory as laboratory sample(s).

6.5.2 Number of increments from stocked materials in big bags

For stocked materials the minimum number of increments is three when using a screw (Figure 3) and six when using a sampler (Figure 4).



Figure 3 — Screw

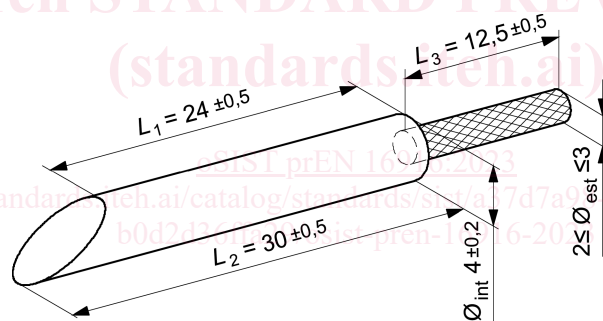

Figure 4 — Sampler

6.6 Storage and transport of laboratory sample(s)

Samples shall be stored in a tight container and in proper dry conditions in order to avoid changes in the humidity of the sample.

7 Procedure

7.1 Reference method

7.1.1 Weigh an empty clean dish or tray (5.2) to the nearest 0,1 g, transfer the sample from the container or bag to the dish or tray and spread the sample evenly, allowing about 1 g of sample per 100 mm² of surface area of the dish or tray respectively or about 0,5 g per 100 mm² for textile samples.

Weigh an identical empty clean dish or tray (reference dish respectively tray) to the nearest 0,1 g.

NOTE 1 A reference dish or a reference tray is included in the procedure for a correction of buoyancy. To avoid absorption of moisture from the atmosphere, the dish or tray (5.2) with the dried sample is reweighed when still