International Standard



2699

INTERNATIONAL ORGANIZATION FOR STANDARDIZATION • МЕЖДУНАРОДНАЯ ОРГАНИЗАЦИЯ ПО СТАНДАРТИЗАЦИИ • ORGANISATION INTERNATIONALE DE NORMALISATION

Road vehicles — Flange-mounted injection nozzle holders size "S" — Types 2, 3, 4, 5 and 6

Véhicules routiers — Porte-injecteurs à bride de taille «S» — Types 2, 3, 4, 5 et 6

Second edition — 1983-11-01

iteh STANDARD PREVIEW
(standards.iteh.ai)

ISO 2699:1983

<https://standards.iteh.ai/catalog/standards/sist/2f39ac45-a80c-443b-b403-e5f5da0c7ac1/iso-2699-1983>

UDC 621.43.03

Ref. No. ISO 2699-1983 (E)

Descriptors : road vehicles, diesel engines, injection nozzle holders, dimensions.

Price based on 5 pages

Foreword

ISO (the International Organization for Standardization) is a worldwide federation of national standards bodies (ISO member bodies). The work of developing International Standards is carried out through ISO technical committees. Every member body interested in a subject for which a technical committee has been authorized has the right to be represented on that committee. International organizations, governmental and non-governmental, in liaison with ISO, also take part in the work.

Draft International Standards adopted by the technical committees are circulated to the member bodies for approval before their acceptance as International Standards by the ISO Council.

International Standard ISO 2699 was developed by Technical Committee ISO/TC 22, *Road vehicles*.

This second edition was submitted directly to the ISO Council, in accordance with clause 6.11.2 of part 1 of the Directives for the technical work of ISO. It cancels and replaces the first edition (i.e. ISO 2699-1974), which had been approved by the member bodies of the following countries :

Australia	Hungary	Switzerland
Belgium	Italy	Thailand
Brazil	Netherlands	Turkey
Bulgaria	Poland	United Kingdom
Czechoslovakia	Romania	USA
Egypt, Arab Rep. of	South Africa, Rep. of	USSR
France	Spain	Yugoslavia
Germany, F. R.	Sweden	

The member body of the following country had expressed disapproval of the document on technical grounds :

Japan

Road vehicles — Flange-mounted injection nozzle holders size "S" — Types 2, 3, 4, 5 and 6

iTeh STANDARD PREVIEW
(standards.iteh.ai)

1 Scope

This International Standard specifies the dimensional requirements for mounting and interchangeability of injection nozzle holders in diesel engines.

The location of the fuel inlet and leak-off connections are not defined since they vary according to the particular application.

2 Field of application

This International Standard applies to flange-mounted injection nozzle holders of size "S", types 2, 3, 4, 5 and 6, used with the nozzles specified in ISO 2697.

3 Reference

ISO 2697, *Road vehicles — Fuel injection nozzles — Size "S"*.

4 Dimensions and tolerances

4.1 General dimensions (the preferred shank lengths are given in 4.2)

4.1.1 Nozzle holder type 2

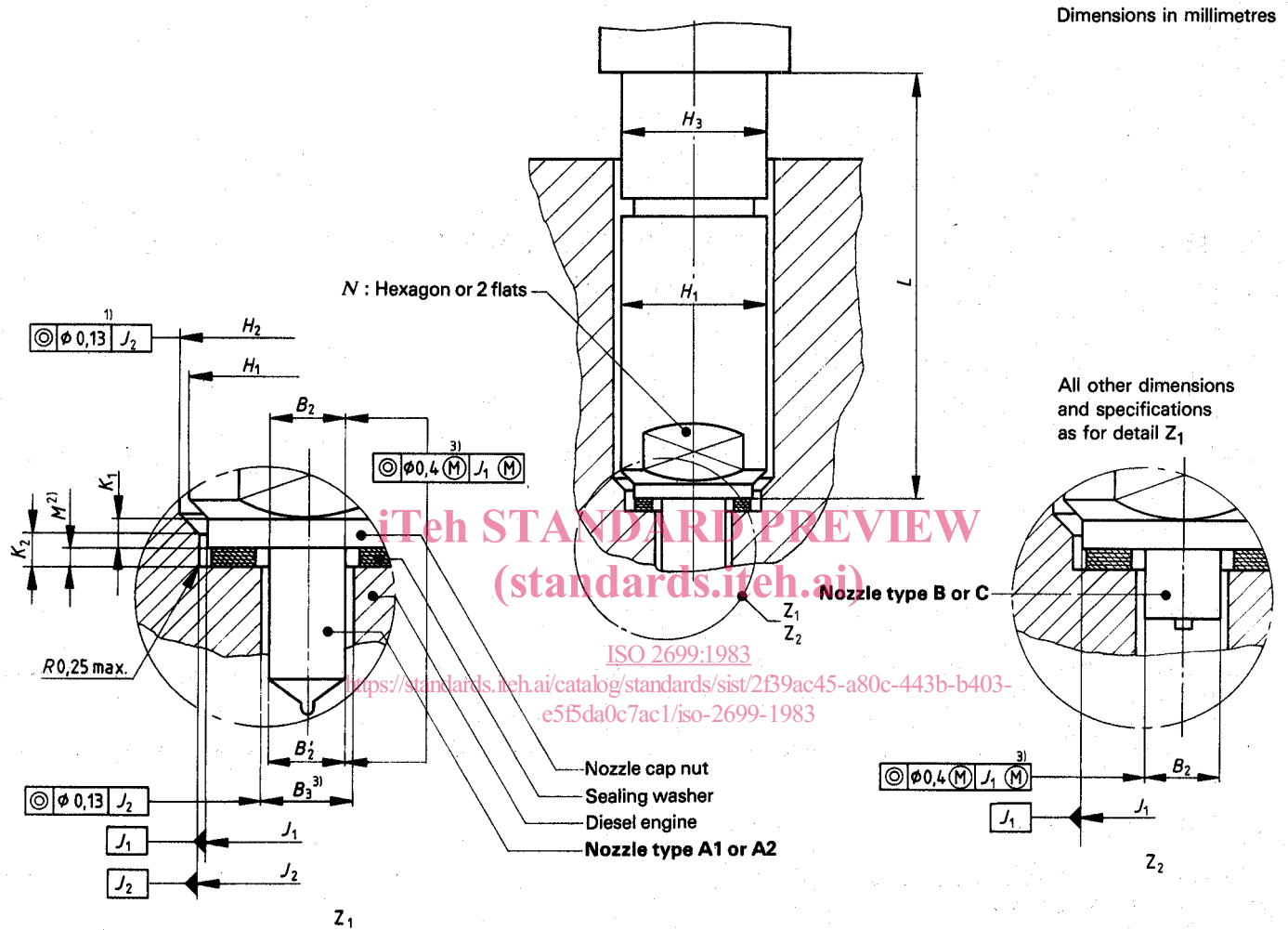

Nozzle holder type	Nozzle type	H ₁ max.	H ₂ min.	H ₃ max.	B ₂	B' ₂ + 0,3 0	B ₃	J ₁ h11	J ₂ C11	K ₁ min.	K ₂ + 1 0	M ²⁾ nom.	N across flats h11
2	A1 - A2	25	25,2	25	9,2 max. (B ₂ > B' ₂)	8,9	3)	21,5	21,5	3,5	3,5	2	22
	B - C				14,0 c11	—							

Figure 1 — Flange-mounted nozzle holder size "S", type 2

- 1) For the nozzle holder type 2, this tolerance applies only in the case where a small clearance exists between H₁ and H₂.
- 2) With commercial tolerance (before compression).
- 3) The determination of the diameter B₃ in the cylinder head is left to the manufacturer's choice. For that purpose the maximum value for the nozzle stem which is given as a result of the *maximum material principle* (M) and the maximum tolerance value of the cylinder head hole must be taken into account. The clearance shall be kept to a minimum to facilitate nozzle cooling.

4.1.2 Nozzle holders types 3 and 4

Dimensions in millimetres

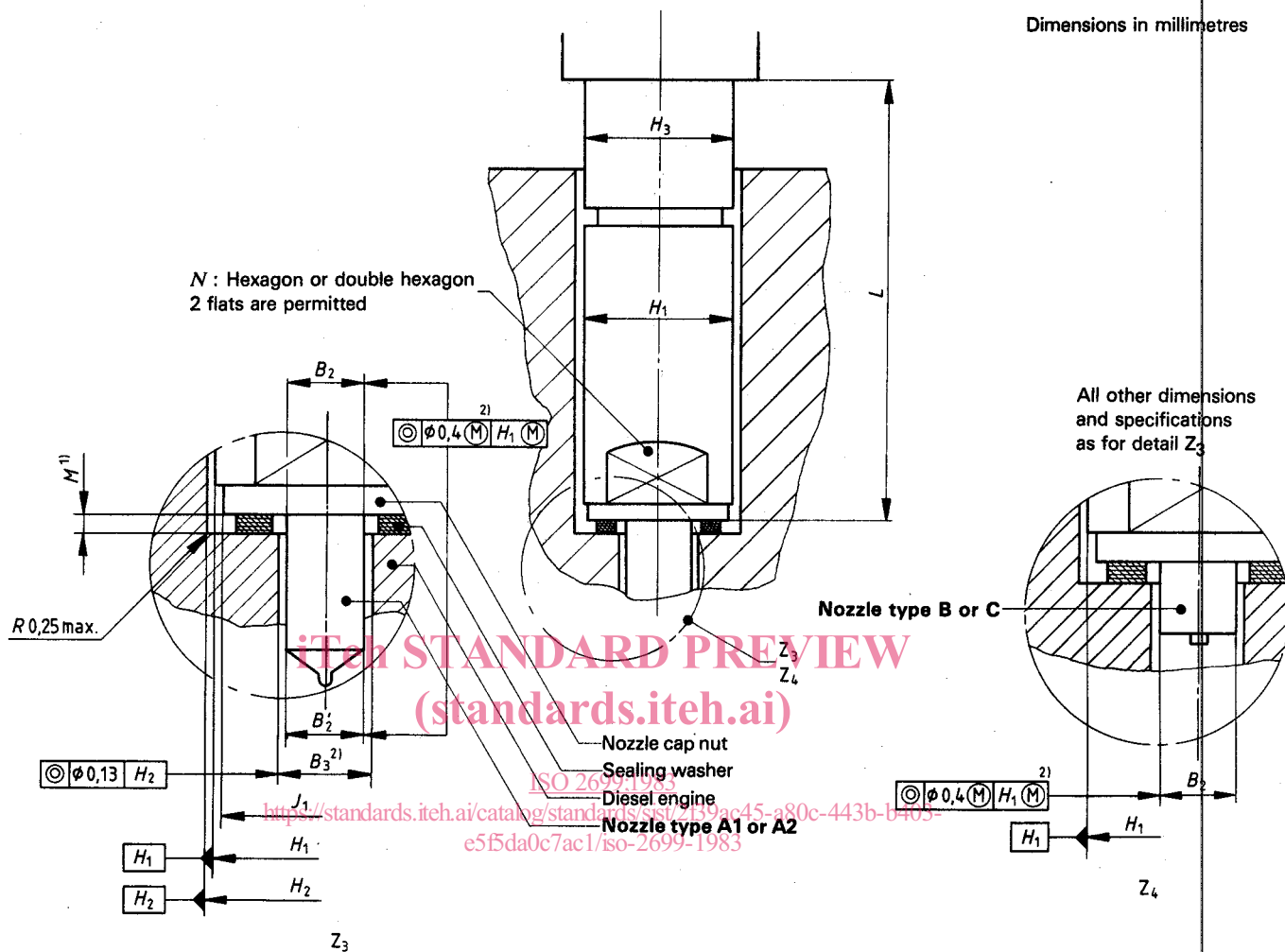

Nozzle holder type	Nozzle type	H_1 max.	H_2 $+ 0,1$ 0	H_3 max.	B_2	B'_2 $+ 0,3$ 0	B_3	J_1 min.	$M^{(1)}$ nom.	N across flats h11
3	A1 - A2	21,5	21,6	21,3	9,2 max. ($B_2 > B'_2$)	8,9	2)	18,5	2	19
4	B - C				14,0 c11	—				

NOTE — Nozzle holders types 3 and 4 are not recommended for future designs.

Figure 2 — Flange-mounted nozzle holder size "S", types 3 and 4

1) See footnote 2) of 4.1.1.

2) See footnote 3) of 4.1.1.

4.1.3 Nozzle holders types 5 and 6

Dimensions in millimetres

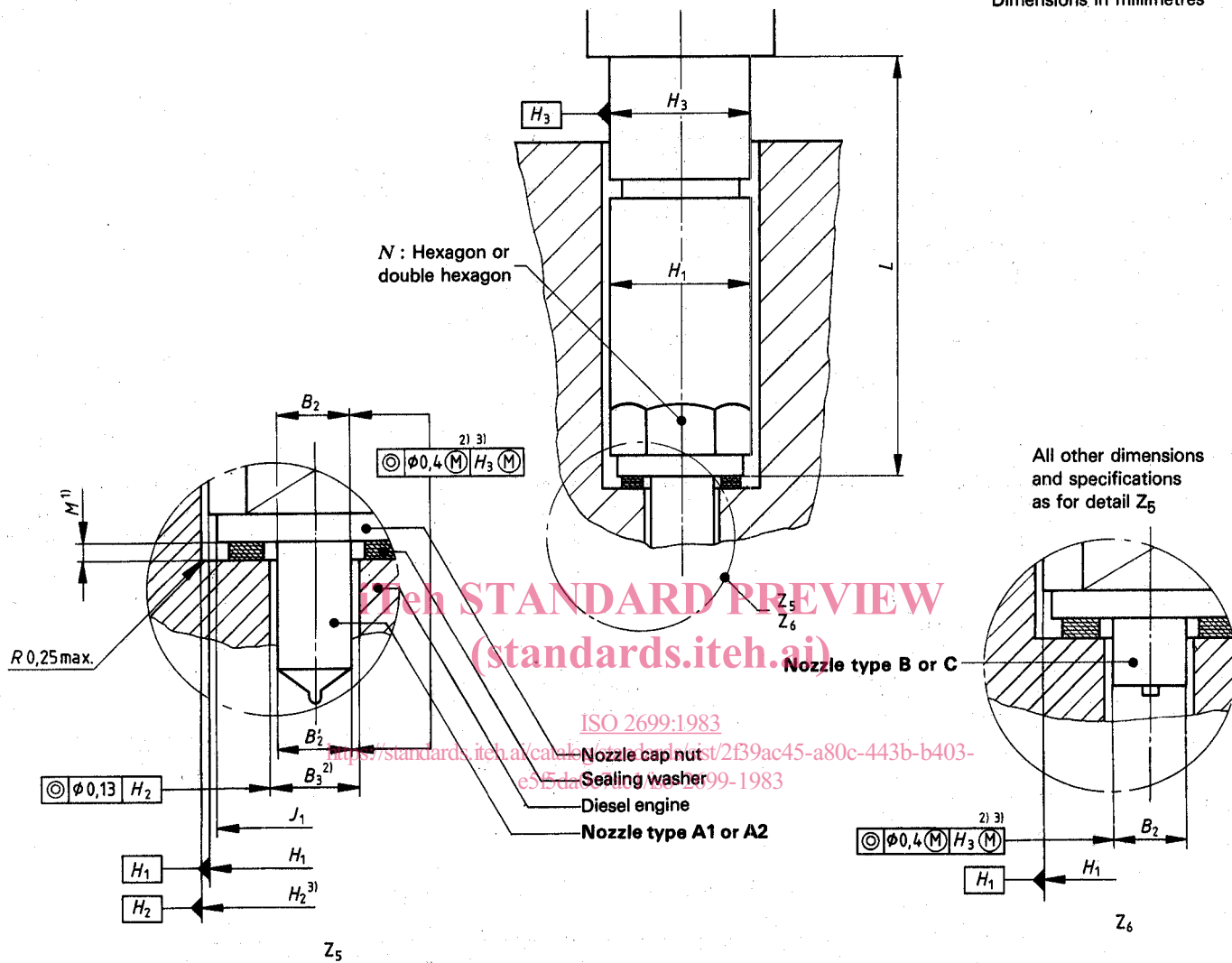

Nozzle holder type	Nozzle type	H ₁ max.	H ₂ ³⁾ + 0,1 0	H ₃ max.	B ₂	B ₂ ' + 0,3 0	B ₃	J ₁ min.	M ¹⁾ nom.	N across flats h11
5	A1 - A2	20,9	21,1	21	9,2 max. (B ₂ > B ₂ ')	8,9	2)	18,5	2	19
6	B - C				14,0 c11	—				

Figure 3 — Flange-mounted nozzle holder size "S", types 5 and 6

1) See footnote 2) of 4.1.1.

2) See footnote 3) of 4.1.1.

3) For type 5 and 6 nozzle holders without shanks dimension H₂ should be reduced by 0,1 mm. In this case the *maximum material principle* (M) in details Z₅ and Z₆ applies on diameter H₁ instead of diameter H₃.

4.2 Preferred shank lengths

Dimensions in millimetres

Nozzle holder type	Nozzle type	$L \pm 0,8$				
		2	A1 – A2	52	67	—
	B – C	35	45,5	50	80	95
3 and 5	A1 – A2	52	67	82	97	112
4 and 6	B – C	35	50	65	80	95

iTeh STANDARD PREVIEW
(standards.iteh.ai)

ISO 2699:1983

<https://standards.iteh.ai/catalog/standards/sist/2f39ac45-a80c-443b-b403-e5f5da0c7ac1/iso-2699-1983>

iTeh STANDARD PREVIEW
(standards.iteh.ai)

ISO 2699:1983

<https://standards.iteh.ai/catalog/standards/sist/2f39ac45-a80c-443b-b403-e5f5da0c7ac1/iso-2699-1983>