**Fans — System effects and system
effect factors**

Ventilateurs — Effet système et facteurs d'effet système

iTeh Standards
(<https://standards.iteh.ai>)
Document Preview

[ISO/TR 16219:2020](https://standards.iteh.ai/catalog/standards/iso/70b65523-339c-4ff1-9772-ec4635d8633e/iso-tr-16219-2020)

<https://standards.iteh.ai/catalog/standards/iso/70b65523-339c-4ff1-9772-ec4635d8633e/iso-tr-16219-2020>



iTeh Standards
(<https://standards.iteh.ai>)
Document Preview

[ISO/TR 16219:2020](https://standards.iteh.ai/catalog/standards/iso/70b65523-339c-4ff1-9772-ec4635d8633e/iso-tr-16219-2020)

<https://standards.iteh.ai/catalog/standards/iso/70b65523-339c-4ff1-9772-ec4635d8633e/iso-tr-16219-2020>



COPYRIGHT PROTECTED DOCUMENT

© ISO 2020

All rights reserved. Unless otherwise specified, or required in the context of its implementation, no part of this publication may be reproduced or utilized otherwise in any form or by any means, electronic or mechanical, including photocopying, or posting on the internet or an intranet, without prior written permission. Permission can be requested from either ISO at the address below or ISO's member body in the country of the requester.

ISO copyright office
CP 401 • Ch. de Blandonnet 8
CH-1214 Vernier, Geneva
Phone: +41 22 749 01 11
Email: copyright@iso.org
Website: www.iso.org

Published in Switzerland

Contents

	Page
Foreword	iv
Introduction	v
1 Scope	1
2 Normative references	1
3 Terms, definitions and symbols	1
4 Origin of fan system effects	2
5 Definitions of system effect factor (SEF)	4
5.1 Inlet SEF.....	4
5.2 Outlet system effect.....	6
6 Examples of inlet SEF	9
6.1 Introduction.....	9
6.2 Axial fans.....	10
6.2.1 Experimental setups.....	10
6.2.2 Results.....	15
6.3 Centrifugal and mixed-flow fans.....	17
6.3.1 Experimental setups.....	17
6.3.2 Results.....	24
7 Examples of outlet SEF	30
7.1 Axial fans.....	30
7.1.1 General.....	30
7.1.2 Experimental setups.....	30
7.1.3 Results.....	30
7.2 Centrifugal and mixed-flow fans.....	32
7.2.1 Experimental setups.....	32
7.2.2 Results.....	33
8 Reducing system effects	34
8.1 General.....	34
8.2 Inlet effects.....	34
8.2.1 General.....	34
8.2.2 Non-uniform flow.....	35
8.2.3 Swirl or vorticity.....	36
8.2.4 Inlet blockage.....	36
8.3 Outlet effects.....	39
8.3.1 General.....	39
8.3.2 Insufficient duct length.....	39
8.3.3 Outlet obstruction.....	40
8.3.4 Non-uniform flow.....	40
8.4 Examples of the effects of poor inlet and outlet connections.....	43
9 Conclusions	44
Annex A (informative) Basic principles on fan performance representation	45
Annex B (informative) Fan system calculation	73
Bibliography	83

Foreword

ISO (the International Organization for Standardization) is a worldwide federation of national standards bodies (ISO member bodies). The work of preparing International Standards is normally carried out through ISO technical committees. Each member body interested in a subject for which a technical committee has been established has the right to be represented on that committee. International organizations, governmental and non-governmental, in liaison with ISO, also take part in the work. ISO collaborates closely with the International Electrotechnical Commission (IEC) on all matters of electrotechnical standardization.

The procedures used to develop this document and those intended for its further maintenance are described in the ISO/IEC Directives, Part 1. In particular, the different approval criteria needed for the different types of ISO documents should be noted. This document was drafted in accordance with the editorial rules of the ISO/IEC Directives, Part 2 (see www.iso.org/directives).

Attention is drawn to the possibility that some of the elements of this document may be the subject of patent rights. ISO shall not be held responsible for identifying any or all such patent rights. Details of any patent rights identified during the development of the document will be in the Introduction and/or on the ISO list of patent declarations received (see www.iso.org/patents).

Any trade name used in this document is information given for the convenience of users and does not constitute an endorsement.

For an explanation of the voluntary nature of standards, the meaning of ISO specific terms and expressions related to conformity assessment, as well as information about ISO's adherence to the World Trade Organization (WTO) principles in the Technical Barriers to Trade (TBT), see www.iso.org/iso/foreword.html.

This document was prepared by Technical Committee ISO/TC 117, *Fans*.

Any feedback or questions on this document should be directed to the user's national standards body. A complete listing of these bodies can be found at www.iso.org/members.html.

[ISO/TR 16219:2020](https://standards.iteh.ai/standards/iso/70b65523-339c-4ff1-9772-ec4635d8633e/iso-tr-16219-2020)

<https://standards.iteh.ai/catalog/standards/iso/70b65523-339c-4ff1-9772-ec4635d8633e/iso-tr-16219-2020>

Introduction

ISO 5801 provides the information for accurately measuring the performance of fans when tested under standardised laboratory conditions. The ducting where specified ensures a fully developed symmetrical velocity profile at the fan inlet. There may also be sufficient straight ducting at the fan outlet to ensure efficient conversion of the distorted velocity profile at the fan outlet to a measurable stable and homogeneous profile at the measuring station.

This document shows how fan performance is affected by both inlet and outlet connections to it. System designers must not only look at the ideal performance curve and calculated system pressure drop but also take into account the losses at the entry and exit points of the fan. These are described in the document.

The concept of the system effect factor (SEF) was introduced to the fan industry by AMCA in 1973. Since its inception it has become widely accepted worldwide. In more recent years it has been realized that the SEF depends not only on the fan type and the fitting geometry but also on the fan design and manufacturing. Some less efficient fans may sometimes be less sensitive to system effect induced by poor inlet flow conditions than more efficient fans of the same type.

Furthermore, the origin of the system effect induced by a fitting at the fan inlet is different from the one due to the same fitting located on the fan outlet. That is why two different definitions of SEF are proposed in this document according to whether the appurtenance is at the fan inlet or fan discharge.

iTeh Standards (<https://standards.iteh.ai>) Document Preview

[ISO/TR 16219:2020](https://standards.iteh.ai/catalog/standards/iso/70b65523-339c-4ff1-9772-ec4635d8633e/iso-tr-16219-2020)

<https://standards.iteh.ai/catalog/standards/iso/70b65523-339c-4ff1-9772-ec4635d8633e/iso-tr-16219-2020>

Fans — System effects and system effect factors

1 Scope

This document deals with the likely degradation of air performance of fans tested in standardized airways in accordance with ISO 5801 when compared with the performance of fans tested under actual site conditions. It deals with the performance of a number of generic types of fan and fittings. The results given are intended as guidelines and only provide trends, as the system effect depends on the exact geometry of the fan and disturbing component.

The test data presented in this document are taken from an extensive experimental program conducted 20 years ago by NEL (National Engineering Laboratory, UK), mainly on axial and centrifugal fans. Data are also taken from several research projects financially supported by ASHRAE, some of them being carried out in the AMCA laboratory in Chicago, as well as from results published previously by individual fan manufacturers.

2 Normative references

There are no normative references in this document.

3 Terms, definitions and symbols

No terms and definitions are listed in this document.

ISO and IEC maintain terminological databases for use in standardization at the following addresses:

— ISO Online browsing platform: available at <https://www.iso.org/obp>

— IEC Electropedia: available at <http://www.electropedia.org/>

The following symbols are used:

Symbol	Description	SI units	I-P units
A_2	Fan outlet area	m ²	ft ²
C	System effect (SE) coefficient (see 5.2)	Dimensionless	Dimensionless
p_C	Conventional pressure loss (see 5.2)	Pa	in. wg
p_f	Fan pressure	Pa	in. wg
p_{fd}	Fan dynamic pressure (see Clause 4)	Pa	in. wg
p_{fs}	Fan static pressure	Pa	in. wg
p_{SE}	System effect (see 5.2)	Pa	in. wg
p_{SEo}	Additional pressure loss due to non-uniform flow (see 5.2)	Pa	in. wg
q_{V1}	Volume flow rate of the fan	m ³ /s	cfm
S_{EF}	System effect factor	Dimensionless	Dimensionless
ξ	Loss coefficient (see 5.1)	(m ³ /s)/(Pa ^{0,5})	
ρ	Density of air	kg/m ³	lbm/ft ³
ρ_{std}	Standard air density	kg/m ³	lbm/ft ³

NOTE The term "fan dynamic pressure" or "dynamic pressure" is used throughout this document and is equivalent to the term "velocity pressure" as used in some countries.

4 Origin of fan system effects

Manufacturers’ fan performance ratings are mostly based on tests carried out in a laboratory under ideal conditions. Ideal conditions refer to uniform, swirl-free air velocity profiles at fan inlet and outlet, like those of the test rigs described in ISO 5801 and AMCA 210. In ‘real life’ fan installations, such ideal conditions may not be present due to improper connection of the fan to the system. Such improper connections include obstacles at fan inlets and outlets that alter the aerodynamic characteristics of the fan and lead to deficient performance in relation to catalogue ratings, even when the system pressure losses have been estimated accurately. The term “system effect” is a measure of this degradation of fan performance.

The origin of system effect is different at fan outlet and at fan inlet. At the fan outlet, for example in the case of an improperly connected outlet fitting such as an elbow, damper or duct branch, the system effect is linked to less-than-optimum non-uniform flow profiles induced by the fan at the entrance to the fitting (Figure 1). This degraded flow will create more pressure loss across the fitting than would be the case when measuring the fitting loss assuming uniform homogeneous flow profiles or when estimating it from standard handbooks such as the ASHRAE Handbook of Fundamentals^[14].

When the fitting is at the fan inlet, for example an elbow or a fan inlet duct/box (Figure 2), the velocity profiles at the inlet to the fitting may be uniform and the fitting pressure loss as measured or estimated from standard handbooks may be valid. However, the flow patterns at the fan inlet (or fitting outlet) may be disturbed with the presence of a vortex, spin or vena-contracta. This less than optimum flow condition at fan inlet caused by the fitting will lead to a reorganization of the flow inside the impeller and therefore a deterioration of fan performance in relation to catalogue ratings. Not only the fan curve may be affected by this disturbing obstacle but also sometimes, but not always, the fan power curve. A companion document will be drafted at a later date to show the influence of the inlet obstacles on the fan power curve for the same configurations of fans and fittings as in this document.

In both cases, the resulting air flow of the fan-system combination deteriorates, but for distinct physical reasons. For this reason, two different definitions and treatment of fan system effect are incorporated, depending on whether the fitting is at the fan inlet or fan outlet. It is also recognized that in some situations, obstacles very close to fan discharge (e.g. side walls at a short distance of a plenum fan impeller as shown in Figure 20) may also deteriorate fan performance in the same manner as components located at fan inlet.

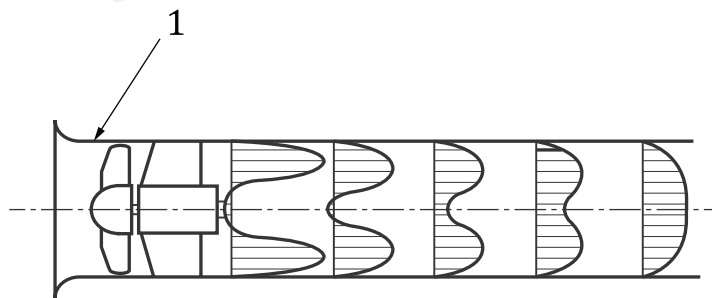

Key
 1 axial fan

Figure 1 — Non-uniform velocity profiles at fan outlet

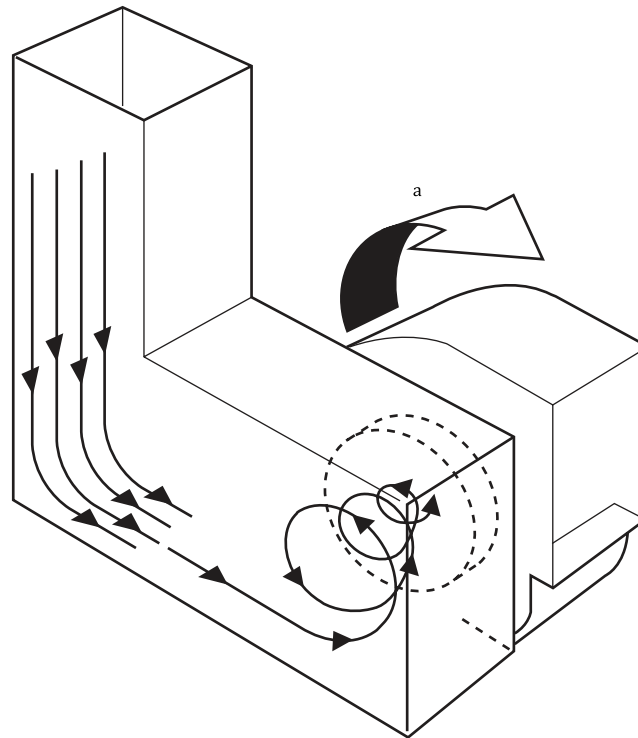

^a Impeller rotation.

Figure 2 — Vortex at fan inlet

An ideal connection to a fan would be one which results in a velocity distribution across the fan inlet connection plane which is relatively uniformly distributed and without appreciable swirl component, as shown in [Figure 3](#).

[ISO/TR 16219:2020](https://standards.iteh.ai/ISO/TR/16219:2020)

<https://standards.iteh.ai/catalog/standards/iso/70b65523-339c-4ff1-9772-ec4635d8633e/iso-tr-16219-2020>

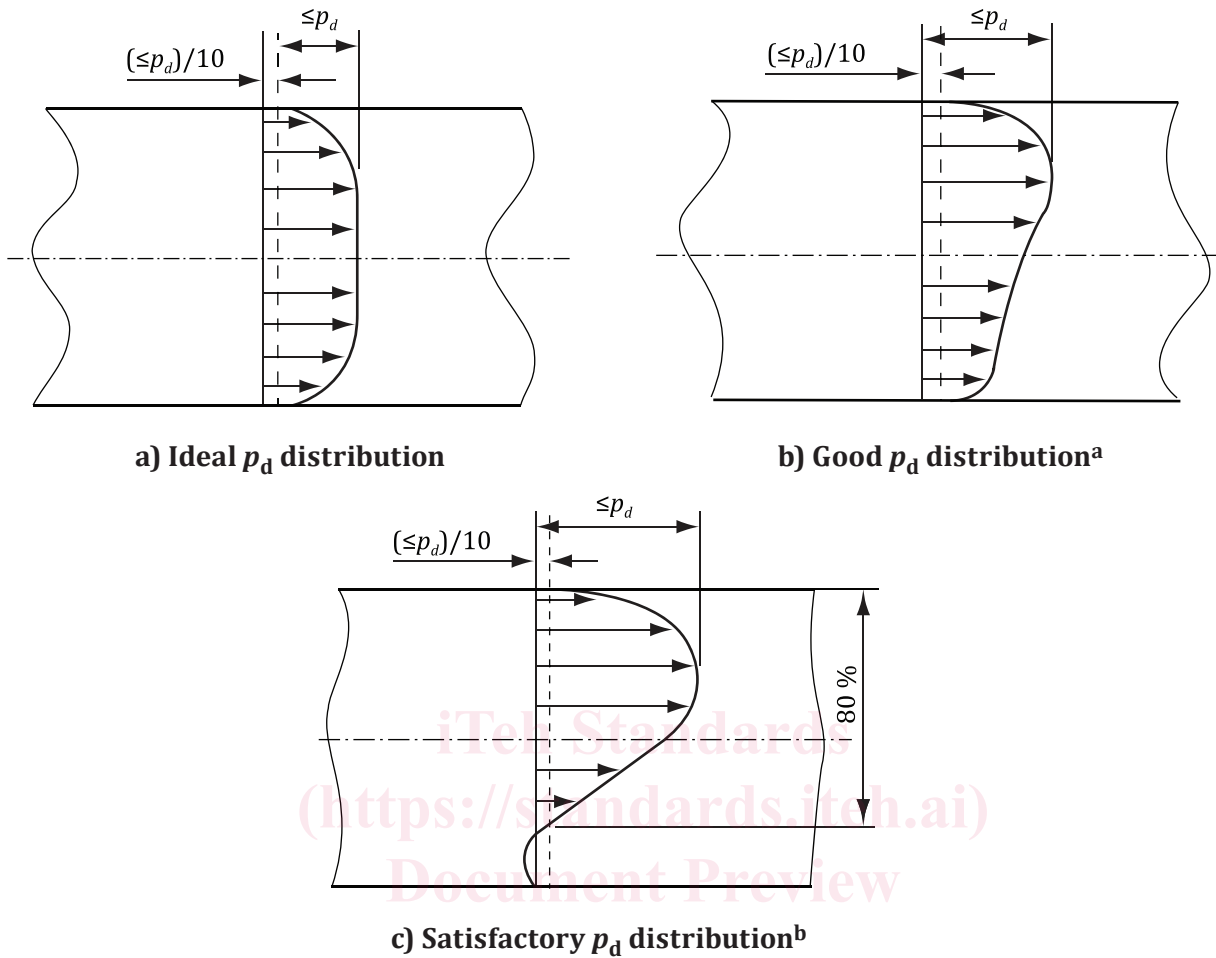

iTel Standards
(<https://standards.itoh.ai>)
Document Preview

ISO/TR 16219:2020

<https://standards.itoh.ai/catalog/standards/iso/70b65523-339c-4ff1-9772-ec4635d8633e/iso-tr-16219-2020>

Key

p_d mean dynamic pressure of the duct flow

^a Also satisfactory for flow into fan inlets, but may be unsatisfactory for flow into inlet boxes, may produce swirl in boxes.

^b More than 75 % of p_d readings greater than $p_{dmax}/10$ (unsatisfactory for flow into fan inlets of inlet boxes).

Figure 3 — Ideal fan connections

5 Definitions of system effect factor (SEF)

5.1 Inlet SEF

With a component at the fan inlet, the SEF is defined as the relative airflow drop $\Delta q_{v1}/q_{v1}$ along a given system line as shown in [Figure 4](#). In this figure, the solid curve and the dotted line curve are the static pressure curves without and with system effect, respectively. The curve with system effect is obtained by adding the pressure loss of the fitting for each flow rate increment, when it may be measured or estimated from guidebooks (e.g. IDEL'CIK), to the static pressure of the fan + inlet fitting combination. This procedure allows for the assessment of the installation effect related to the degradation of the fan curve itself without accounting for the pressure loss of the fitting.

To quantify the system effect on the whole fan curve, the quantity $\Delta q_{V1}/q_{V1}$ is plotted versus the system resistance coefficient $\xi = q_{V1} / \sqrt{p_{fs}}$ (p_{fs} being the fan static pressure at q_{V1})¹⁾ in Figure 5.

The SEF for a given fan + inlet fitting configuration is the average of $\Delta q_{V1}/q_{V1}$ over the ξ range, presented as a percentage in the results. $\Delta q_{V1}/q_{V1}$ is positive when the flow with the inlet fitting is lower than that of the free inlet configuration.

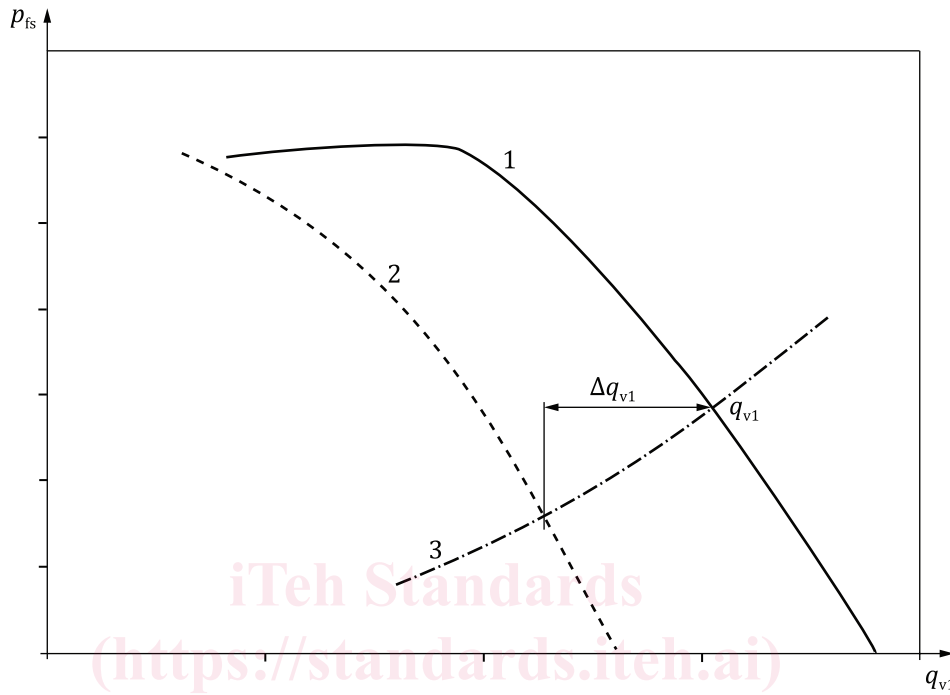

Key

- q_{V1} volume flow rate of the fan
- p_{fs} fan pressure
- 1 fan curve without system effect
- 2 fan curve with system effect
- 3 system line

Figure 4 — Definition of q_{V1} and Δq_{V1} on a given system line

1) q_{V1} is either in cfm or m^3/s while p_{fs} is either in in. wg or Pa.

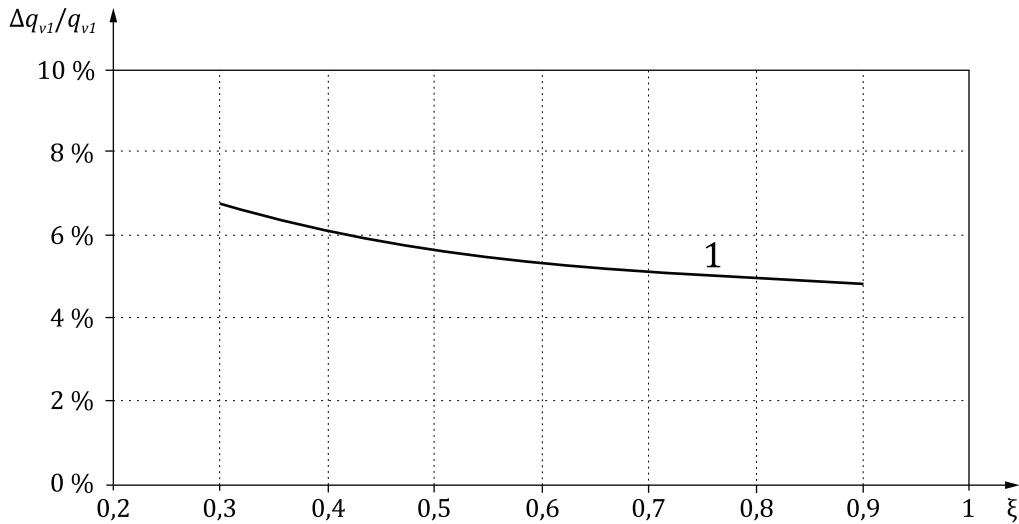

Key

- $\Delta q_{v1}/q_{v1}$ relative flow drop in volume flow rate of the fan
- ξ system resistance coefficient
- 1 system effect curve

Figure 5 — Example of relative flow drop $\Delta q_{v1}/q_{v1}$ versus system resistance coefficient ξ

[Clause 6](#) describes various situations resulting in inlet system effects.

5.2 Outlet system effect

Outlet system effect is a measure of the pressure losses across fan outlet appurtenances such as an outlet duct, elbow, volume control damper, duct branch or plenum, due to non-uniform outlet flow induced by the fan and improper outlet connections. [16219:2020](#)

Most fans, for applications requiring systems connected at their outlets, are tested and rated for performance with an outlet duct 2 to 3 'equivalent duct diameter' long. The outlet duct helps control the diffusion of the outlet flow and establish a uniform velocity profile ([Figure 6](#)). In most cases, it is not practical for the fan manufacturer to supply this duct as part of the fan, but rated performance will not be achieved unless a comparable duct is included in system design.

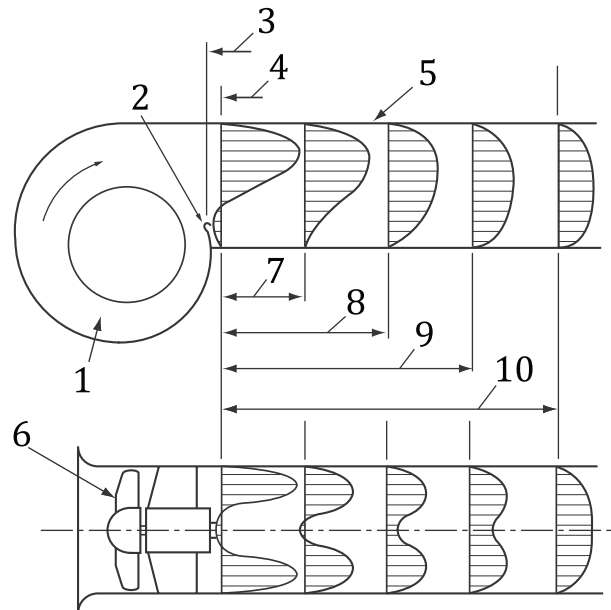
**Key**

- 1 centrifugal fan
- 2 cutoff
- 3 blast area
- 4 outlet area
- 5 discharge duct
- 6 axial fan
- 7 25 % effective duct length
- 8 50 % effective duct length
- 9 75 % effective duct length
- 10 100 % effective duct length

iTech Standards
(<https://standards.itih.ai>)
Document Preview

ISO/TR 16219:2020
<https://standards.itih.ai/catalog/standards/iso/70b65523-339c-4ff1-9772-ec4635d8633e/iso-tr-16219-2020>

Figure 6 — Velocity profiles at fan outlet

The techniques documented to estimate pressure losses of a fitting such as an elbow or the published pressure drop performance from a manufacturer of a fitting such as a damper are based upon uniform approach velocity profiles. The pressure loss so estimated is referred to as the ‘conventional pressure loss’ across the fitting. Unless uniform approach velocity profile is ensured, there will be additional pressure losses across these fittings. Outlet system effect is used to estimate the actual pressure loss across the fitting in a given installation.

[Clause 7](#) describes various situations resulting in outlet system effects. The total outlet system effect, p_{SE} (Pa), for a given situation (fitting) is defined as:

$$p_{SE} = p_c + p_{SE0}$$

where

p_c is conventional pressure loss (Pa);

p_{SE0} is additional pressure loss due to non-uniform flow (Pa).

ISO/TR 16219:2020(E)

p_{SE0} can be expressed as a function of flow by the following formula:

$$p_{SE0} = C \times p_{fd2}$$

where

p_{fd2} is dynamic pressure at fan outlet $0,5 \cdot \rho \cdot (q_{V1}/A_2)^2$;

q_{V1} is fan airflow rate, m³/s;

A_2 is fan outlet area in m²;

C is system effect coefficient;

ρ is air density in kg/m³.

The outlet system effect p_{SE} at each flow rate q_{V1} must be added to the design system curve to obtain the actual system curve ([Figure 7](#)).

The system effect coefficient C is averaged over the fan curve to obtain what is called the outlet SEF in [Clause 7](#).

$P_B - P_A$ = fitting conventional pressure drop at design flow

$P_C - P_B$ = outlet system effect, p_{SE0} , at design flow

$P_E - P_D$ = fitting conventional pressure drop at actual flow

$P_F - P_E$ = outlet system effect, p_{SE0} , at actual flow

iteh Standards
(<https://standards.iteh.ai>)
Document Preview

[ISO/TR 16219:2020](#)

<https://standards.iteh.ai/catalog/standards/iso/70b65523-339c-4ff1-9772-ec4635d8633e/iso-tr-16219-2020>