**Plastics — Injection moulding of
test specimens of thermoplastic
materials —**

**Part 3:
Small plates**

iTeh STANDARD PREVIEW
*Plastiques — Moulage par injection des éprouvettes de matériaux
thermoplastiques —
(standards.iteh.ai)
Partie 3: Plaques de petites dimensions*

[ISO 294-3:2020](https://standards.iteh.ai/catalog/standards/sist/2410ae0a-875c-4b93-a097-d3f663f1973a/iso-294-3-2020)

[https://standards.iteh.ai/catalog/standards/sist/2410ae0a-875c-4b93-a097-
d3f663f1973a/iso-294-3-2020](https://standards.iteh.ai/catalog/standards/sist/2410ae0a-875c-4b93-a097-d3f663f1973a/iso-294-3-2020)



iTeh STANDARD PREVIEW (standards.iteh.ai)

ISO 294-3:2020

<https://standards.iteh.ai/catalog/standards/sist/2410ae0a-875c-4b93-a097-d3f663f1973a/iso-294-3-2020>



COPYRIGHT PROTECTED DOCUMENT

© ISO 2020

All rights reserved. Unless otherwise specified, or required in the context of its implementation, no part of this publication may be reproduced or utilized otherwise in any form or by any means, electronic or mechanical, including photocopying, or posting on the internet or an intranet, without prior written permission. Permission can be requested from either ISO at the address below or ISO's member body in the country of the requester.

ISO copyright office
CP 401 • Ch. de Blandonnet 8
CH-1214 Vernier, Geneva
Phone: +41 22 749 01 11
Fax: +41 22 749 09 47
Email: copyright@iso.org
Website: www.iso.org

Published in Switzerland

Contents

Page

Foreword	iv
1 Scope	1
2 Normative references	1
3 Terms and definitions	1
4 Apparatus	1
4.1 Type D11 and D12 ISO moulds.....	1
4.2 Injection-moulding machine.....	5
5 Procedure	6
5.1 Conditioning of material.....	6
5.2 Injection moulding.....	6
6 Report on test-specimen preparation	6
Annex A (informative) Weld lines	7
Bibliography	9

iTeh STANDARD PREVIEW (standards.iteh.ai)

ISO 294-3:2020

<https://standards.iteh.ai/catalog/standards/sist/2410ae0a-875c-4b93-a097-d3f663f1973a/iso-294-3-2020>

Foreword

ISO (the International Organization for Standardization) is a worldwide federation of national standards bodies (ISO member bodies). The work of preparing International Standards is normally carried out through ISO technical committees. Each member body interested in a subject for which a technical committee has been established has the right to be represented on that committee. International organizations, governmental and non-governmental, in liaison with ISO, also take part in the work. ISO collaborates closely with the International Electrotechnical Commission (IEC) on all matters of electrotechnical standardization.

The procedures used to develop this document and those intended for its further maintenance are described in the ISO/IEC Directives, Part 1. In particular, the different approval criteria needed for the different types of ISO documents should be noted. This document was drafted in accordance with the editorial rules of the ISO/IEC Directives, Part 2 (see www.iso.org/directives).

Attention is drawn to the possibility that some of the elements of this document may be the subject of patent rights. ISO shall not be held responsible for identifying any or all such patent rights. Details of any patent rights identified during the development of the document will be in the Introduction and/or on the ISO list of patent declarations received (see www.iso.org/patents).

Any trade name used in this document is information given for the convenience of users and does not constitute an endorsement.

For an explanation of the voluntary nature of standards, the meaning of ISO specific terms and expressions related to conformity assessment, as well as information about ISO's adherence to the World Trade Organization (WTO) principles in the Technical Barriers to Trade (TBT) see www.iso.org/iso/foreword.html.

This document was prepared by Technical Committee ISO/TC 61, *Plastics*, Subcommittee SC 9, *Thermoplastic materials*, in collaboration with the European Committee for Standardization (CEN) Technical Committee CEN/TC 249, *Plastics*, in accordance with the Agreement on technical cooperation between ISO and CEN (Vienna Agreement).

This third edition cancels and replaces the second edition (ISO 294-3:2002), which has been technically revised. It also incorporates the Amendment ISO 294-3:2002/Amd 1:2006.

The main changes compared to the previous edition are as follows:

- the requirements in [Clause 4](#) have been clarified;
- the position of h_G in [Figure 2](#) has been corrected.

A list of all parts in the ISO 294 series can be found on the ISO website.

Any feedback or questions on this document should be directed to the user's national standards body. A complete listing of these bodies can be found at www.iso.org/members.html.

Plastics — Injection moulding of test specimens of thermoplastic materials —

Part 3: Small plates

1 Scope

This document specifies two two-cavity moulds, the type D11 and D12 ISO moulds, for the injection moulding of small plates measuring 60 mm × 60 mm with a preferred thickness of 1 mm (type D11) or 2 mm (type D12), which can be used for a variety of tests. The moulds can additionally be fitted with inserts for studying the effects of weld lines on the mechanical properties (see [Annex A](#)).

2 Normative references

The following documents are referred to in the text in such a way that some or all of their content constitutes requirements of this document. For dated references, only the edition cited applies. For undated references, the latest edition of the referenced document (including any amendments) applies.

ISO 294-1:2017, *Plastics — Injection moulding of test specimens of thermoplastic materials — Part 1: General principles, and moulding of multipurpose and bar test specimens*

ISO 294-4, *Plastics — Injection moulding of test specimens of thermoplastic materials — Part 4: Determination of moulding shrinkage*

ISO 6603-1, *Plastics — Determination of puncture impact behaviour of rigid plastics — Part 1: Non-instrumented impact testing*

3 Terms and definitions

For the purposes of this document, the terms and definitions given in ISO 294-1 apply.

ISO and IEC maintain terminological databases for use in standardization at the following addresses:

- ISO Online browsing platform: available at <https://www.iso.org/obp>
- IEC Electropedia: available at <http://www.electropedia.org/>

4 Apparatus

4.1 Type D11 and D12 ISO moulds

Type D11 and D12 ISO moulds are two-cavity moulds (see [Figure 1](#)) intended for the preparation of plates measuring 60 mm × 60 mm. The plates produced using these moulds shall have the dimensions shown in [Figure 2](#) and given in [Table 1](#).

The main constructional details of type D11 and D12 ISO moulds shall be as shown in [Figure 1](#) and [Figure 2](#) and shall meet the following requirements.

- a) The sprue diameter on the nozzle side shall be at least 4 mm according to ISO 294-1:2017, 4.1.1.4, item a).

- b) Runner length l_R and runner depth h_R see [Table 1](#); runner design according to [Figure 2](#).
- c) The cavities as shown in [Figure 1](#) shall be one-end gated according to ISO 294-1:2017, 4.1.1.4, item c).
- d) The height of the gate shall be at least (75 ± 5) % of the height of the cavity and the width of the gate shall be equal to that of the cavity at the point where the gate enters the cavity.
- e) The gate length shall be $(4 \pm 0,1)$ mm.
- f) The draft angle of the runners shall be according to ISO 294-1:2017, 4.1.1.4, item f).
- g) The dimensions of the cavities shall fulfill requirement of ISO 294-1:2017, 4.1.1.4, item g). According to ISO 6603-1, the main dimensions, in millimetres, of the cavities shall be as follows (see also [Figure 2](#)):
- length: 60 to 62;
 - width: 60 to 62;
 - depth: type D12 mould 2,0 to 2,1
type D11 mould 1,0 to 1,1.
- h) Ejector pins, if used, shall be located outside the test area, i.e. outside the 50-mm-diameter central section of the plate specimen.
- i) Heating/cooling system for the mould plates shall be designed according to ISO 294-1:2017, 4.1.1.4, item i).
- j) Interchangeable cavity plates as well as gate inserts shall be designed according to ISO 294-1:2017, 4.1.1.4, item j).
- k) [Figure 2](#) shows the position of a pressure sensor P within the cavity, which is mandatory for the measurement of moulding shrinkage according to ISO 294-4. It might be useful, however, in controlling the injections period with any ISO mould (see ISO 294-1:2017, 4.1.1.4 item k)). The pressure sensor shall be flush with the cavity surface in order to avoid interference of the melt flow.
- l) To ensure that cavity plates are interchangeable between different ISO moulds see ISO 294-1:2017, 4.1.1.4, item l) for construction details.
- m) Marking of individual cavities according to ISO 294-1:2017, 4.1.1.4, item m).
- n) Polishing of surface imperfections according to ISO 294-1:2017, 4.1.1.4, item n).

NOTE 1 Gates which are severely limited in height have a great influence on the orientation of the material within the cavity, even at large distances from the gate. The change in height at the gate has therefore been fixed at a value which facilitates subsequent measurement of the moulding shrinkage (see ISO 294-4).

NOTE 2 The height and length of the gate strongly influence the process of solidification of the melt as it flows into the cavity, and hence the moulding shrinkage (see ISO 294-4). The dimensions of the gate are therefore defined with tight tolerances.

NOTE 3 The value specified for the gate length l_G allows the two test specimens to be cut from the runners with a fixed distance l_C between the cuts (see [Figure 1](#)), even when the moulding shrinkage varies from one material to another.

NOTE 4 The distance l_C between the lines along which the test specimens are cut from the runners (see [Figure 1](#)) is given by $l_C = 2(l_G + l_R + l^*)$ (see [Figure 2](#)). Taking this distance as 80 mm gives the advantage that the same cutting machine can be used to cut 80 mm × 10 mm × 4 mm bars from the central sections of multipurpose test specimens [see ISO 294-1:2017, 4.1.1.4, item l)].

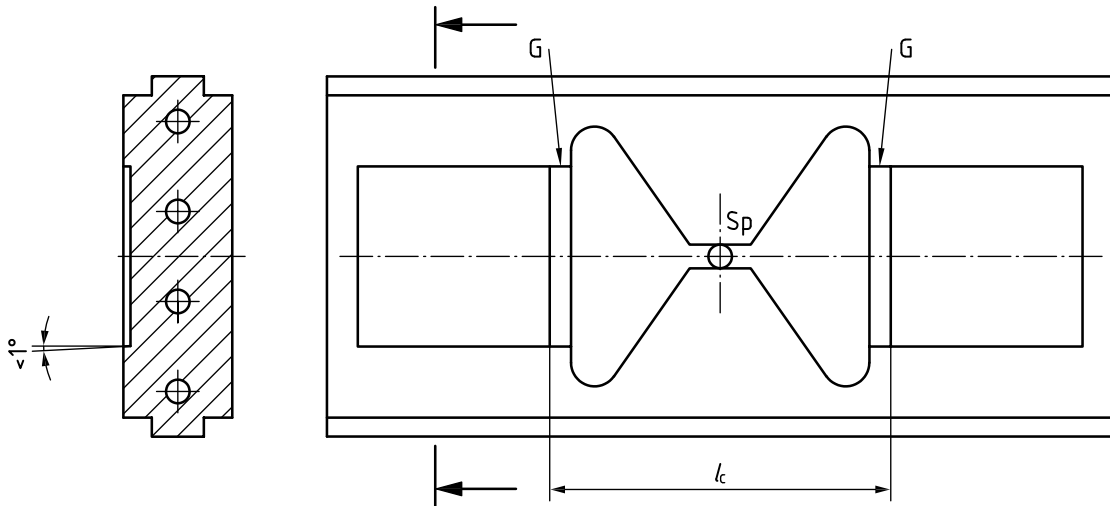
**Key**

Sp sprue

G gate

 l_c distance between the lines along which the test specimens are cut from the runners (see 4.1, NOTES 3 and 4)NOTE 1 Moulding volume V_M approximately 23 000 mm³ (at 2 mm thickness).NOTE 2 Projected area A_p approximately 11 000 mm².**Figure 1 — Cavity plate for type D11 and D12 ISO moulds**

ISO 294-3:2020

<https://standards.iteh.ai/catalog/standards/sist/2410ae0a-875c-4b93-a097-d3f663f1973a/iso-294-3-2020>

Table 1 — Dimensions of plates produced with type D11 and D12 ISO moulds

Dimensions in millimetres

l	Length of plate	60 ± 2^a
b	Width of plate	60 ± 2^a
h	Thickness of plate:	type D11 mould type D12 mould
		$1,0 \pm 0,1$ $2,0 \pm 0,1^a$
l_G	Length of gate	$4,0 \pm 0,1^b$
h_G	Height of gate	$(0,75 \pm 0,05) \times h^c$
l_R	Length of runner	25 to 30 ^d
b_R	Width of runner at gate	$\geq (b + 6)$
h_R	Depth of runner	h
l^*	Unspecified distance	—
l_p	Distance of pressure sensor from gate	5 ± 2 $l_p + r_p \leq 10^e$ $l_p - r_p \geq 0$

NOTE The dimensions of the plates given in this table differ from the cavity dimensions given in 4.1 g), because shrinkage can be accounted for by larger mould dimensions compared to the final part dimensions.

^a These dimensions are for the preferred test specimen used in ISO 6603-1.

^b See 4.1, NOTES 2 and 3.

^c See 4.1, NOTES 1 and 2.

^d See 4.1, NOTE 4.

^e Where r_p is the radius of the sensor.

ITIH STANDARD PREVIEW
(standards.iteh.ai)

ISO 294-3:2020

<https://standards.iteh.ai/catalog/standards/sist/2410ae0a-875c-4b93-a097-d3f663f1973a/iso-294-3-2020>

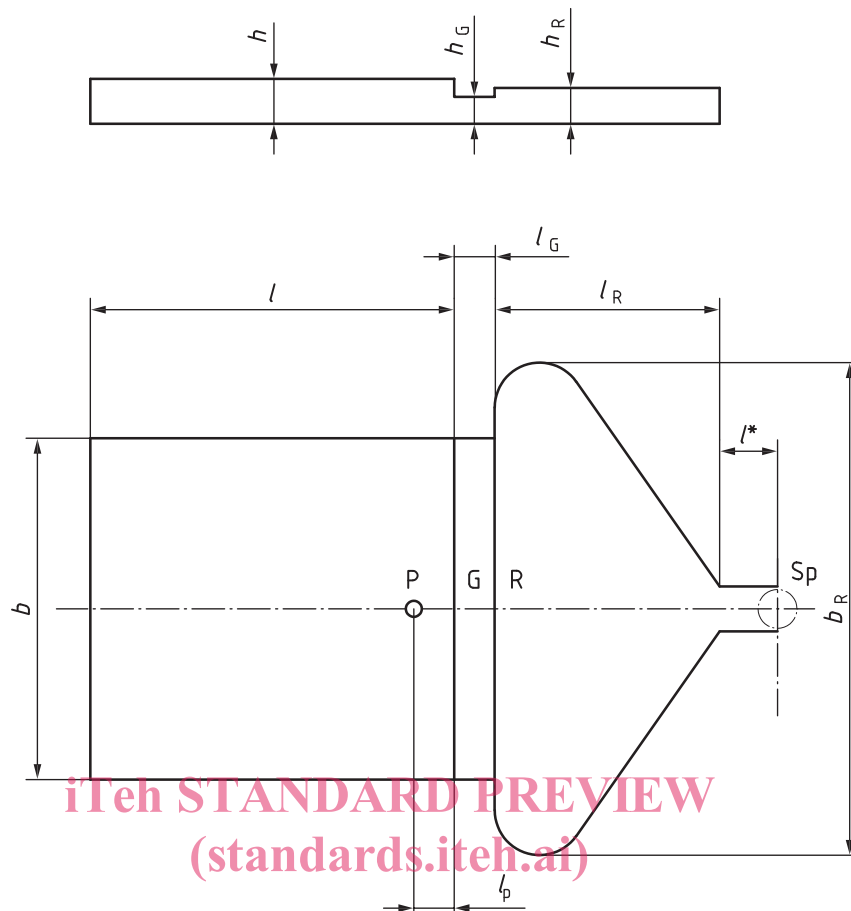

ISO 294-3:2020

<https://standards.iteh.ai/catalog/standards/sist/2410ae0a-875c-4b93-a097-d3f663f1973a/iso-294-3-2020>

Key

- Sp sprue
- R runner
- G gate
- P pressure sensor
- l^* unspecified distance
- l_G length of gate

NOTE For the other symbols, see [Table 1](#).

Figure 2 — Details of type D11 and D12 ISO moulds

4.2 Injection-moulding machine

As specified in ISO 294-1:2017, 4.2, with the following exception:

In ISO 294-1:2017, 4.2.5, the recommended minimum locking force F_M for type D11 and type D12 ISO moulds is given by

$$F_M \geq 11\,000 \times p_{\max} \times 10^{-3}, \text{ i.e. } 880 \text{ kN}$$

for a maximum melt pressure p_{\max} of 80 MPa.