**Assistive products for walking
manipulated by both arms —
Requirements and test methods —**

**Part 1:
Walking frames**

iTeh STANDARD PREVIEW
*Produits d'assistance à la marche manipulés avec les deux bras —
Exigences et méthodes d'essai —
Partie 1: Cadres de marche*
(standards.iteh.ai)

ISO 11199-1:2021

<https://standards.iteh.ai/catalog/standards/sist/b35df120-2403-427d-a07a-06d38dfc9e38/iso-11199-1-2021>



iTeh STANDARD PREVIEW
(standards.iteh.ai)

ISO 11199-1:2021

<https://standards.iteh.ai/catalog/standards/sist/b35df120-2403-427d-a07a-06d38dfc9e38/iso-11199-1-2021>



COPYRIGHT PROTECTED DOCUMENT

© ISO 2021

All rights reserved. Unless otherwise specified, or required in the context of its implementation, no part of this publication may be reproduced or utilized otherwise in any form or by any means, electronic or mechanical, including photocopying, or posting on the internet or an intranet, without prior written permission. Permission can be requested from either ISO at the address below or ISO's member body in the country of the requester.

ISO copyright office
CP 401 • Ch. de Blandonnet 8
CH-1214 Vernier, Geneva
Phone: +41 22 749 01 11
Email: copyright@iso.org
Website: www.iso.org

Published in Switzerland

Contents

	Page
Foreword	v
Introduction	vi
1 Scope	1
2 Normative references	1
3 Terms and definitions	1
4 Apparatus	6
5 Test conditions	6
6 General requirements and test methods	7
6.1 Risk analysis.....	7
6.2 Walking frames that can be dismantled.....	8
6.3 Fasteners.....	8
6.4 User mass/Load limits.....	8
6.5 Structure requirements.....	8
6.6 Brakes.....	8
6.6.1 Requirements.....	8
6.6.2 Test method.....	9
6.7 Handgrip.....	9
6.8 Leg section and tip.....	9
7 Materials	9
7.1 General.....	9
7.2 Flammability.....	10
7.3 Biocompatibility and toxicity.....	10
7.4 Infection and microbiological contamination.....	10
7.4.1 General.....	10
7.4.2 Cleaning and disinfection.....	10
7.5 Resistance to corrosion.....	10
8 Ingress of liquids	10
9 Temperatures of parts that come in contact with human skin	11
10 Safety of moving parts	11
10.1 Squeezing.....	11
10.2 Mechanical wear.....	12
11 Prevention of traps for parts of the human body	12
11.1 Holes and clearances.....	12
11.2 V-shape openings.....	12
12 Folding, adjusting and locking mechanisms	12
12.1 General.....	12
12.2 Folding mechanisms.....	13
12.3 Locking mechanisms.....	13
13 Lifting and carrying handles	13
13.1 General.....	13
13.2 Requirement.....	13
13.3 Test method.....	14
14 Surfaces, corners and edges	14
15 Static stability	14
15.1 Requirements for static stability.....	14
15.2 Test method for static stability.....	15
15.2.1 General requirement.....	15
15.2.2 Forward-direction static stability test.....	15

ISO 11199-1:2021(E)

15.2.3	Rearward-direction static stability test.....	16
15.2.4	Sideway-direction static stability test.....	17
16	Static strength	18
16.1	Static strength of walking frame.....	18
16.1.1	General requirement.....	18
16.1.2	Requirements for static strength of walking frame.....	18
16.1.3	Test method for static strength of walking frame.....	18
16.2	Static strength for the legs with tip.....	19
16.2.1	General requirement.....	19
16.2.2	Requirements for static strength of the legs with tip.....	19
16.2.3	Test method for static strength of the legs with tip.....	19
17	Durability test	20
17.1	General requirement.....	20
17.2	Requirement for durability.....	20
17.3	Test method for durability.....	20
18	Ergonomic principles	21
19	Packaging	21
20	Information supplied by the manufacturer	21
20.1	General.....	21
20.2	Information marked on the product.....	22
20.3	Instruction manual.....	22
20.4	Test report.....	23
Annex A (informative)	Consideration items for hazards when designing the products	25
Annex B (informative)	General recommendations	27
Bibliography	ISO 11199-1:2021	29

<https://standards.iteh.ai/catalog/standards/sist/b35df120-2403-427d-a07a-06d38dfc9e38/iso-11199-1-2021>

Foreword

ISO (the International Organization for Standardization) is a worldwide federation of national standards bodies (ISO member bodies). The work of preparing International Standards is normally carried out through ISO technical committees. Each member body interested in a subject for which a technical committee has been established has the right to be represented on that committee. International organizations, governmental and non-governmental, in liaison with ISO, also take part in the work. ISO collaborates closely with the International Electrotechnical Commission (IEC) on all matters of electrotechnical standardization.

The procedures used to develop this document and those intended for its further maintenance are described in the ISO/IEC Directives, Part 1. In particular, the different approval criteria needed for the different types of ISO documents should be noted. This document was drafted in accordance with the editorial rules of the ISO/IEC Directives, Part 2 (see www.iso.org/directives).

Attention is drawn to the possibility that some of the elements of this document may be the subject of patent rights. ISO shall not be held responsible for identifying any or all such patent rights. Details of any patent rights identified during the development of the document will be in the Introduction and/or on the ISO list of patent declarations received (see www.iso.org/patents).

Any trade name used in this document is information given for the convenience of users and does not constitute an endorsement.

For an explanation of the voluntary nature of standards, the meaning of ISO specific terms and expressions related to conformity assessment, as well as information about ISO's adherence to the World Trade Organization (WTO) principles in the Technical Barriers to Trade (TBT), see www.iso.org/iso/foreword.html.

This document was prepared by Technical Committee ISO/TC 173, *Assistive products*, in collaboration with the European Committee for Standardization (CEN) Technical Committee CEN/TC 293, *Assistive products and accessibility*, in accordance with the Agreement on technical cooperation between ISO and CEN (Vienna Agreement).

This second edition cancels and replaces the first edition (ISO 11199-1:1999), which has been technically revised.

The main changes compared to the previous edition are as follows:

- [3.1](#) was changed to be in accordance with ISO 9999;
- [Clause 6](#), on general requirements for assistive products for walking, was added.

A list of all parts in the ISO 11199 series can be found on the ISO website.

Any feedback or questions on this document should be directed to the user's national standards body. A complete listing of these bodies can be found at www.iso.org/members.html.

Introduction

A walking frame can be used when a person needs assistance when walking. The walking frame can provide stability when walking and standing and reduce the risk of falling. Walking frames are designed to support the user inside a frame to carry the user's full body weight.

iTeh STANDARD PREVIEW (standards.iteh.ai)

ISO 11199-1:2021

<https://standards.iteh.ai/catalog/standards/sist/b35df120-2403-427d-a07a-06d38dfc9e38/iso-11199-1-2021>

Assistive products for walking manipulated by both arms — Requirements and test methods —

Part 1: Walking frames

1 Scope

This document specifies requirements and test methods for walking frames used as assistive products for walking, manipulated by both arms, without accessories, unless specified in the particular test procedure. This document also gives requirements relating to safety, ergonomics, performance and information supplied by the manufacturer, including marking and labelling.

The requirements and tests are based on everyday use of walking frames as assistive products for walking for a maximum user mass as specified by the manufacturer. This document includes walking frames specified for a user mass of no less than 35 kg.

2 Normative references

The following documents are referred to in the text in such a way that some or all of their content constitutes requirements of this document. For dated references, only the edition cited applies. For undated references, the latest edition of the referenced document (including any amendments) applies.

ISO 8191-2, *Furniture — Assessment of ignitability of upholstered furniture — Part 2: Ignition source: match-flame equivalent*

ISO 10993-1, *Biological evaluation of medical devices — Part 1: Evaluation and testing within a risk management process*

ISO 13732-1, *Ergonomics of the thermal environment — Methods for the assessment of human responses to contact with surfaces — Part 1: Hot surfaces*

ISO 14971, *Medical devices — Application of risk management to medical devices*

ISO 15223-1, *Medical device – Symbols to be used with medical device labels, labelling and information to be supplied – Part 1: General requirements*

ISO 20417, *Medical devices — Information to be supplied by the manufacturer*

ISO 24415-1, *Tips for assistive products for walking — Requirements and test methods — Part 1: Friction of tips*

ISO 7000, *Graphical symbols for use on equipment — Registered symbols*

EN 614-1+A1, *Safety of machinery - Ergonomic design principles - Part 1: Terminology and general principles*

3 Terms and definitions

For the purposes of this document, the following terms and definitions apply.

ISO and IEC maintain terminological databases for use in standardization at the following addresses:

— ISO Online browsing platform: available at <https://www.iso.org/obp>

— IEC Electropedia: available at <http://www.electropedia.org/>

**3.1
brake**

device for slowing or stopping motion of a walking frame by contact friction

**3.2
front handgrip reference point**

position on the upper surface of the handgrip located 30 mm from the front end of the handgrip length

Note 1 to entry: See [Figure 1](#).

**3.3
handgrip**

part of the walking frame that is intended by the manufacturer to be held by the hand when the walking frame is in use

Note 1 to entry: See [Figure 1](#).

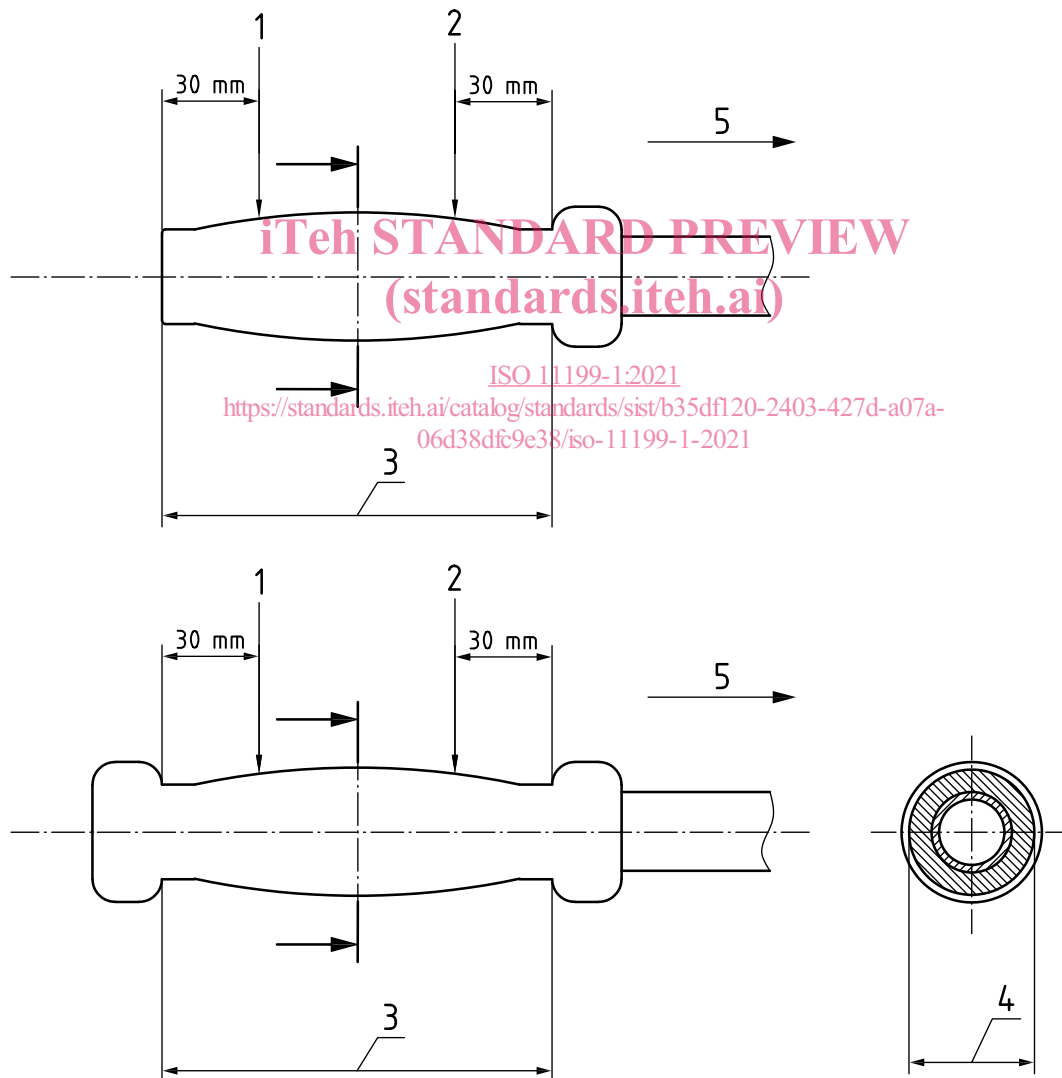

Key

- | | | | |
|---|--------------------------------|---|----------------|
| 1 | rear handgrip reference point | 4 | handgrip width |
| 2 | front handgrip reference point | 5 | front |
| 3 | handgrip length | | |

Figure 1 — Details of a handgrip

3.4 handgrip length

dimension of the handgrip measured where the hand rests

Note 1 to entry: See [Figure 1](#).

Note 2 to entry: Where the front end or the rear end of the handgrip is not clear, the full length of the handgrip that can comfortably support the mass of the user is defined as the handgrip length.

3.5 handgrip width

outside dimension of the handgrip measured at the thickest point where the hand rests

Note 1 to entry: See [Figure 1](#).

3.6 handle

part of the walking frame to which the handgrip is attached

3.7 maximum user mass

greatest permissible mass of the person using the product, measured in kilograms (kg)

Note 1 to entry: The maximum user mass is specified by the manufacturer of the walking frame.

3.8 maximum width

maximum outside dimension of a walking frame when the adjustments are at their maximum. measured horizontally at right angles to the direction of movement when the walking frame is in normal use

Note 1 to entry: See [Figure 3](#).

3.9 parking brake

brake system that is intended for keeping the walking frame stationary on ground after being activated

3.10 pressure brake

running brake that engages when a vertical load is applied on the handgrips or on supporting points of the walking frame

Note 1 to entry: See [Figure 2](#)

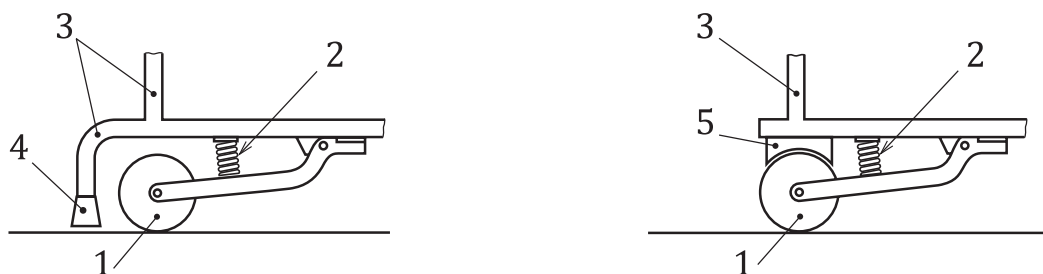

Key

1	wheel	4	rubber tip (brake)
2	spring	5	brake pad
3	frame		

Figure 2 — Two types of pressure brake with technical details

3.11 rear handgrip reference point

position on the upper surface of the handgrip located 30 mm from the rear end of the handgrip length

Note 1 to entry: See [Figure 1](#).

Note 2 to entry: If the grip protrudes further than the handle, the measurement is made from the end of the handle.

3.12 reciprocal walking frame

walking frame where each side of the frame moves alternately, allowing unilateral forward progression through the whole gait cycle

3.13 running brake

brake that is operated by the user during walking and where the braking effect depends proportionally on the activation force applied

3.14 tip
part of a walking frame that is in contact with the ground

3.15 turning diameter
diameter of the largest circle described by a walking frame when the adjustments are at their maximum and walking frame is turned through 360° about its own central vertical axis

Note 1 to entry: See [Figure 3](#).

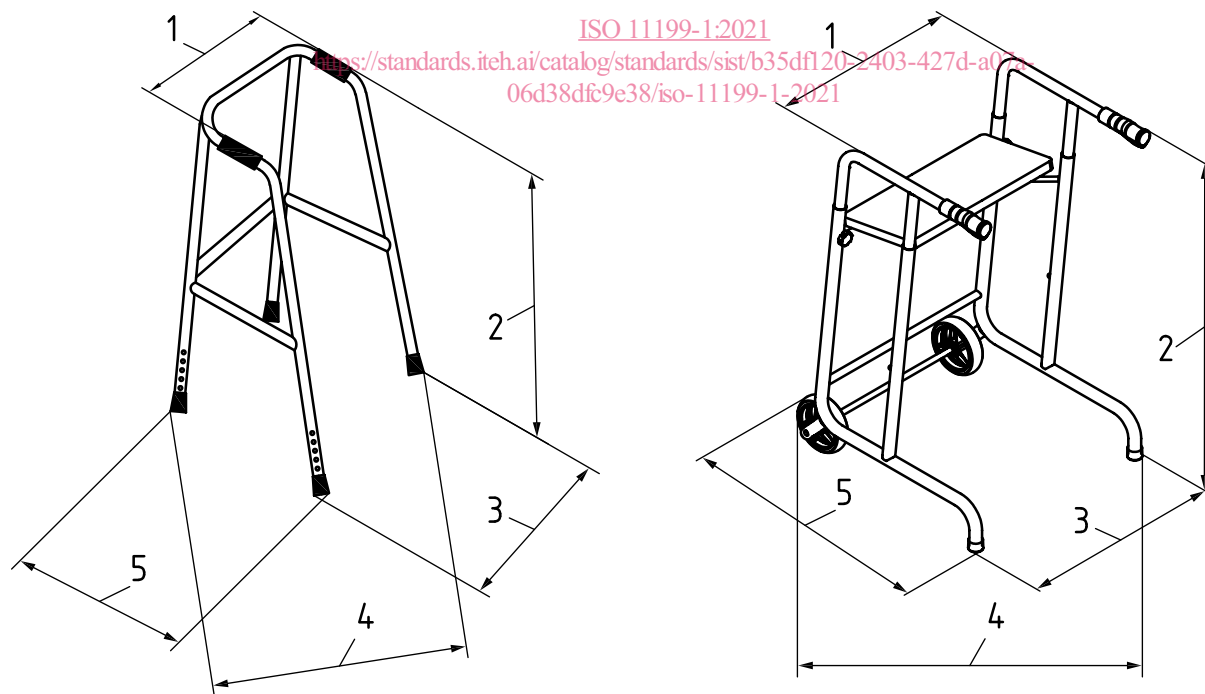

Key

- | | | | |
|---|-----------------------|---|------------------|
| 1 | width between handles | 4 | turning diameter |
| 2 | height | 5 | length |
| 3 | width | | |

Figure 3 — Dimensions of a walking frame

3.16 walking frame

frame that a person lifts to move, which enables to support full body weight and to maintain stability and balance while walking or standing with hand grips, without forearm supports and with either four tips or two tips and two castors/wheels

Note 1 to entry: See [Figure 4](#).

Note 2 to entry: ISO 9999, Classification No. 12 06 03.

Note 3 to entry: Double or more castors/wheels used for one pivot position shall be counted as one castor/wheel. The caster/wheel with a pressure brake shall be considered as the tip.

Note 4 to entry: Examples of walking frames include rigid or articulated walking frames assistive products for walking with two wheels combination with two rubber stick buffers/tips.

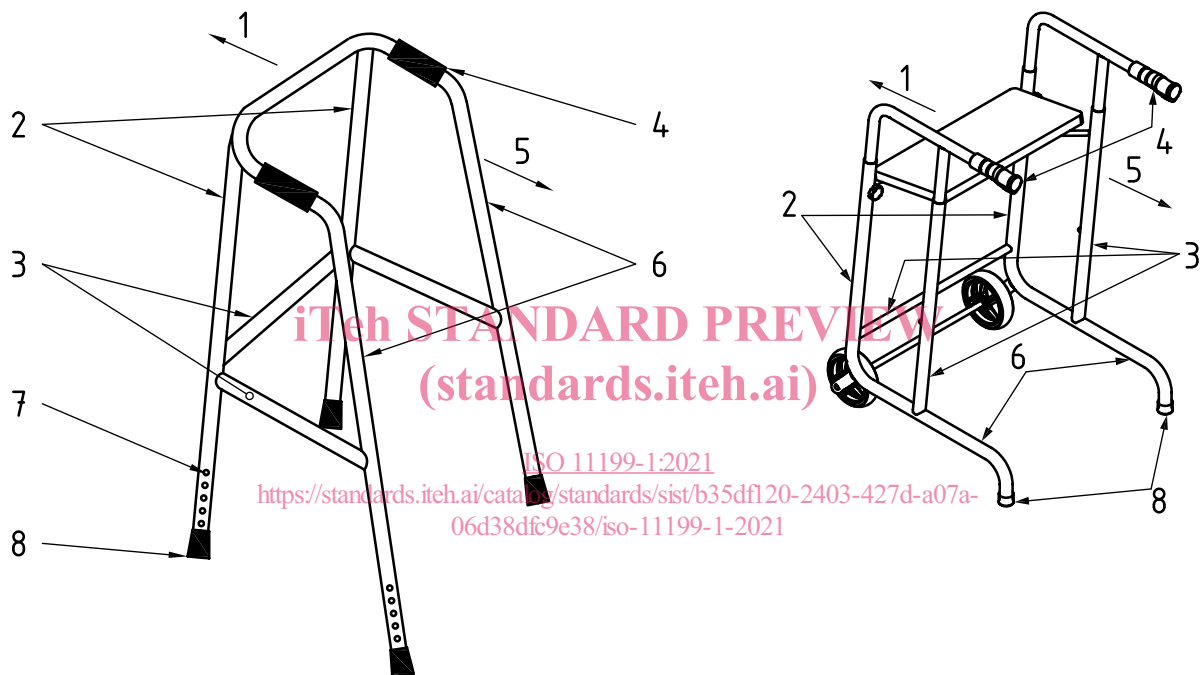

Key

1	front	5	rear
2	front legs	6	rear legs
3	bracing members	7	head adjustment mechanism
4	handgrip	8	tips

Figure 4 — Example of walking frame

3.17 wheel width

maximum dimension of the tyre of the wheel measured within 5 mm up from the walking surface when the walking frame is unloaded

Note 1 to entry: See [Figure 5](#).

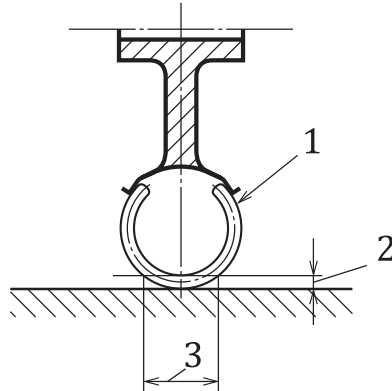

Key

- 1 tyre
- 2 0 to 5 mm up from the walking surface
- 3 wheel width

Figure 5 — Wheel width measurement

4 Apparatus

4.1 Means to apply a force with an accuracy of $\pm 5\%$ and with a rate of application less than 1 N/s.

4.2 Means to measure force with an accuracy of $\pm 5\%$ in increments of 1 N.

4.3 Means to measure distance in the range of 0 m to 3 m with an accuracy of ± 5 mm or $\pm 2\%$, whichever is the greater

4.4 Means to measure angles to an accuracy of $\pm 0,5^\circ$.

4.5 Means to measure torque with an accuracy of $\pm 5\%$ in increments of 1 Nm in the range of 0,5 Nm to 10 Nm

4.6 A test plane of sufficient size and stiffness to support the walking frame during testing, such that the whole surface is contained between two imaginary parallel planes 5 mm apart. The test plane can be adjustable, or fixed.

NOTE 1 A wooden or steel frame with a plywood surface can be used.

NOTE 2 A test surface of 1,5 m x 2 m is usually of sufficient size.

4.7 Stoppers devices of sufficient height to prevent the walking frame from moving during testing, without interfering with the test or the walking frame.

4.8 Equipment for measuring pressure of air with an accuracy of $\pm 5\%$

5 Test conditions

The following conditions shall be applied:

- a) The tests shall be performed at an ambient temperature of $21\text{ }^\circ\text{C} \pm 5\text{ }^\circ\text{C}$.
- b) Adjustable parts of the walking frame shall be adjusted to the most adverse position according to manufacturer's instruction unless otherwise specified in the test procedure.