



Designation: ~~D2096-00~~ (Reapproved 2010) Designation: D2096 – 11

Standard Test Method for Colorfastness and Transfer of Color in the Washing of Leather¹

This standard is issued under the fixed designation D2096; the number immediately following the designation indicates the year of original adoption or, in the case of revision, the year of last revision. A number in parentheses indicates the year of last reapproval. A superscript epsilon (ϵ) indicates an editorial change since the last revision or reapproval.

This standard has been approved for use by agencies of the Department of Defense.

1. Scope

1.1 This test method covers the determination of the colorfastness of colored leathers, with or without a surface coating. The leathers to be tested are of the type normally expected to withstand frequent laundering. This test method also covers the simultaneous staining of adjacent textile materials when the leather specimens are washed. This test method does not apply to wet blue. Two procedures are covered depending on the apparatus used:

1.1.1 *Procedure A*, using the Launder-Ometer,² and

1.1.2 *Procedure B*, using an alternative washing machine.

1.2 The values stated in inch-pound units are to be regarded as the standard. The values stated in parentheses are provided for information only.

1.3 *This standard does not purport to address all of the safety concerns, if any, associated with its use. It is the responsibility of the user of this standard to establish appropriate safety and health practices and determine the applicability of regulatory limitations prior to use.*

2. Referenced Documents

2.1 *ASTM Standards*:³

D 499 [Standard Specification for White Floating Toilet Soap](#)⁴

2.2 *ISO Standard*:⁵

ISO R105/I, Part 2 Gray Scale for Evaluating Change in Color

ISO R105/I, Part 3 Gray Scale for Evaluating Staining

2.3 *ASTM Adjunct*:⁶

Leather washing apparatus (1 drawing)

3. Summary of Test Method

3.1 Three leather specimens 50 by 80 mm (approximately 2 by 3 in.), and one piece of multifiber test fabric of nearly equal size are washed together in soapy water at 120°F (49°C). After ½ h of washing, the leather specimens and cloth are removed and rinsed carefully in running water at about 95°F (35°C). One leather specimen and the test cloth are removed and air-dried. A new piece of test cloth is added to the remaining two leather specimens and these are washed, as above, for ½ h. The rinsing is repeated; again one leather specimen and the test cloth are removed for drying. The remaining leather specimen, with a new piece of test cloth, is washed again for ½ h. This final leather specimen and test cloth are then rinsed and dried as above. When dry, the color

¹ This test method is under the jurisdiction of ASTM Committee D31 on Leather and is the direct responsibility of Subcommittee D31.04 on Apparel. This test method was developed in cooperation with the American Leather Chemists Assn.

Current edition approved April 1, 2010; 2011. Published May 2010; April 2011. Originally approved in 1962. Last previous edition approved in 2005; 2010 as D2096 – 00 (2005)E1. (2010). DOI: 10.1520/D2096-00R10.10.1520/D2096-11.

² The Launder-Ometer and its development are described in the *American Dyestuff Reporter*, Oct. 29, 1928, p. 679. It is described also in the current *Technical Manual of the American Association of Textile Chemists and Colorists*. The Launder-Ometer is manufactured by Atlas Electric Devices Co., 4114 N. Ravenswood Ave., Chicago, IL 60613; telephone: (773) 327-4520; fax: (773) 327-5787. Such an apparatus is illustrated in Figs. 3, 4, and 5, Oct. 29, 1928, p. 679. It is described also in the current *Technical Manual of the American Association of Textile Chemists and Colorists*. Such an apparatus is illustrated in Figs. 3, 4, and 5.

The sole source of supply of the apparatus known to the committee at this time is SDL Atlas, 3934 Airway Drive, Rock Hill SC 29732. If you are aware of alternative suppliers, please provide this information to ASTM International Headquarters. Your comments will receive careful consideration at a meeting of the responsible technical committee, which you may attend.

³ For referenced ASTM standards, visit the ASTM website, www.astm.org, or contact ASTM Customer Service at service@astm.org. For *Annual Book of ASTM Standards* volume information, refer to the standard's Document Summary page on the ASTM website.

⁴ Withdrawn. The last approved version of this historical standard is referenced on www.astm.org.

⁵ Available from American National Standards Institute (ANSI), 25 W. 43rd St., 4th Floor, New York, NY 10036, http://www.ansi.org.

⁶ Detailed drawings for such an apparatus are available from ASTM International Headquarters. Order Adjunct ADJD2096. Original adjunct produced in 1962.

of the washed leather specimens is rated by comparing it with an unwashed piece of leather. Transfer of color to the test fabric is rated by comparison with an unwashed piece of test fabric. These comparisons are made with the aid of the proper Gray Scale. All ratings are made on dry test specimens.

4. Significance and Use

4.1 The procedure is intended, primarily to evaluate the ability of a leather specimen to withstand fixed, and rather strenuous, laundering conditions. This test is not intended as a recommended washing procedure, neither household nor commercial. Although this test concerns itself with colorfastness and transfer of color during washing, the washed leather specimens are available also for comparing other properties (that is, tensile strength, area change, change in outline, etc.) with those of unwashed samples.

5. Apparatus

5.1 *Washing Machine*—A Launder-Ometer, or an assembly of apparatus capable of similar test conditions (Note 1). In either machine, 1-pt (500-mL) specimen containers are held with their bases toward a horizontal shaft and 2-in. (50 mm) out from its center of rotation. Speed of rotation shall be 40 to 45 rpm. Provision shall be made for maintaining the initial temperature of the specimen containers throughout the test. Additional agitation shall be provided by ¼-in. (6.4 mm) stainless steel balls in the specimen containers.

NOTE 1—A motor-driven assembly, designed to hold 1-pt (500-mL) specimen containers so that they are relative to the axis of the motor shaft in the same way as in the Launder-Ometer, can be used.⁶ The entire assembly, fitted with specimen containers, shall be turned at 40 to 45 rpm inside a simple boxlike container which is heated at 120°F (49°C) with thermostatic control. Thus, heat loss from the preheated contents of the specimen containers is held at a minimum during the 30-min washing periods. Such an apparatus is illustrated in Figs. 1 and 2.

5.2 *Specimen Containers*, glass or stainless steel, 1-pt (500-mL), washer, and cap.

5.3 *Balls*, type 316 stainless steel, ¼-in. (6.4-mm) diameter, 20 per specimen container.

5.4 *Test Cloth*,⁷ multifiber, 50 by 80 mm, three pieces per test.

NOTE 2—Multifiber test fabrics are available in 6-fiber cloth, containing filling strips of wool, Orlon,⁸ Dacron,⁸ nylon-66, bleached cotton, and acetate, assembled in 2-in. (50-mm) repeats. Tests may be run with any test fabric of special interest and reported accordingly.

<https://standards.iteh.ai>

⁷ The sole source of supply of the test cloth known to the committee at this time is Testfabrics, Inc., 200 Blackford Ave., P.O. Box 420, Middlesex, NJ 08846-0420; telephone: (201) 469-6446; fax: (201) 469-1147. If you are aware of alternative suppliers, please provide this information to ASTM Headquarters. Your comments will receive careful consideration at a meeting of the responsible technical committee, which you may attend.

⁸ Trademark of E. I. du Pont de Nemours & Co.



FIG. 1 Washing Machine, Heated Air Bath (Procedure B)

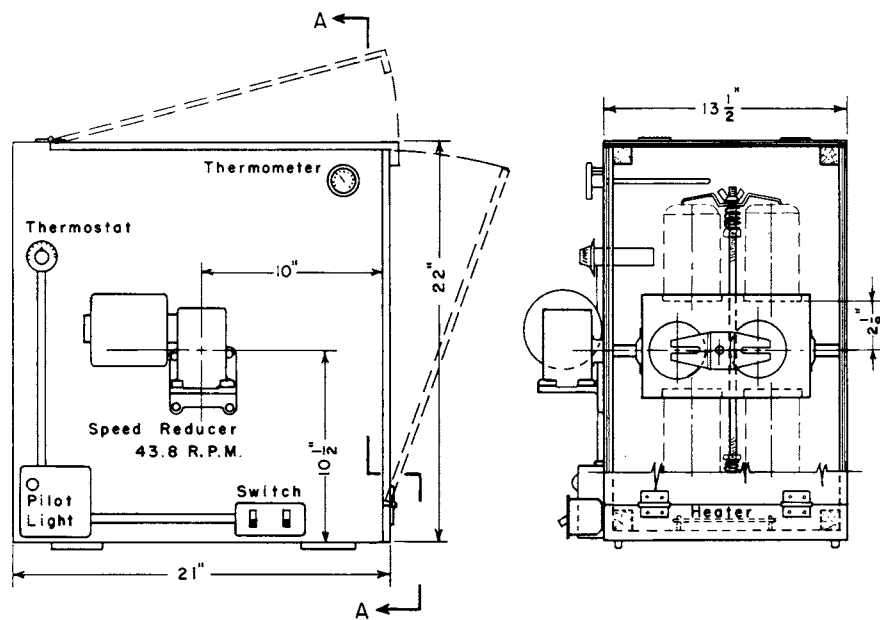

in.	2 1/8	10	10 1/2	13 1/2	21	22
mm	54	254	267	343	533	559

FIG. 2 Diagram of Washing Machine (Procedure B)

iTeh Standards
 (https://standards.iteh.ai)
 Document Preview

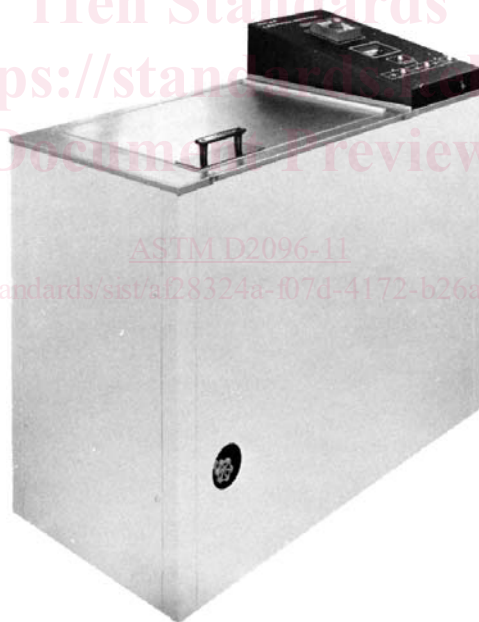

FIG. 3 Launder-Ometer (Procedure A)

5.5 Gray Scales,⁹ consisting of the following:

- 5.5.1 ISO R105/I, Part 2, British, for assessing the effect in fastness testing, and
- 5.5.2 ISO R105/I, Part 3, British, for determining the degree of staining in fastness testing.

⁹ These scales and their use are described in the 1989 Technical Manual of the American Association of Textile Chemists and Colorists. Additional references on the use of Gray Scales in leather washing tests are as follows:

Journal, JSLTC, Society Leather Trades Chemists, Vol 43, 1959, pp. 117-128.

Journal, JSLTC, Society Leather Trades Chemists, Vol 40, 1956, pp. 183-184.

Journal, JSLTC, Society Leather Trades Chemists, Vol 42, 1958, pp. 229-231.

The Gray Scales are available from the American Association of Textile Chemists and Colorists, Box 12215, Research Triangle Park, NC 27709.