



# Standard Test Method for Fire Tests of Penetration Firestop Systems<sup>1</sup>

This standard is issued under the fixed designation E814; the number immediately following the designation indicates the year of original adoption or, in the case of revision, the year of last revision. A number in parentheses indicates the year of last reapproval. A superscript epsilon ( $\epsilon$ ) indicates an editorial change since the last revision or reapproval.

*This standard has been approved for use by agencies of the Department of Defense.*

## INTRODUCTION

Characteristically fire spreads from one building compartment to another by the collapse of a barrier, or by openings through which flames or hot gases may pass, or by transfer of sufficient heat to ignite combustibles beyond the barrier. Test Methods E119 describe the method to be used to measure the fire-resistive performance of these barriers.

However, various techniques of providing for the distribution of services within a structure sometimes require that openings be made in fire-resistive walls and floors to allow the passage of such penetrating items as cables, conduits, pipes, trays, and ducts through to the adjacent compartment. Fire-stop material is installed into these openings to resist the spread of fire.

The performance of through-penetration firestops should be measured and specified according to a common standard that describes the method of fire exposure and rating criteria.

## 1. Scope

1.1 This test method is applicable to firestop systems of various materials and construction. Firestop systems are intended for use in openings in fire-resistive walls and floors that are evaluated in accordance with Test Methods E119.

1.2 Tests conducted in conformance with this test method record firestop system performance during the test exposure; but such tests shall not be construed to determine suitability of the firestop system for use after test exposure.

1.3 This test method also measures the resistance of firestop systems to an external force stimulated by a hose stream. However, this test method shall not be construed as determining the performance of the firestop system during actual fire conditions when subjected to forces such as failure of cable support systems and falling debris.

1.4 The intent of this test method is to develop data to assist others in determining the suitability of the firestops for use where fire resistance is required.

1.5 This test method does not apply to membrane penetrations of a floor-ceiling assembly or roof-ceiling assembly that are tested as part of the assembly in accordance with Test Methods E119.

1.6 This test method does not apply to membrane penetrations of load-bearing walls.

1.7 The values stated in inch-pound units are to be regarded as standard. The values given in parentheses are mathematical conversions to SI units that are provided for information only and are not considered standard.

1.8 *This standard is used to measure and describe the response of materials, products, or assemblies to heat and flame under controlled conditions, but does not by itself incorporate all factors required for fire-hazard or fire-risk assessment of materials, products, or assemblies under actual fire conditions.*

1.9 *This standard does not purport to address all of the safety concerns, if any, associated with its use. It is the responsibility of the user of this standard to establish appropriate safety and health practices and determine the applicability of regulatory limitations prior to use.*

1.10 The text of this standard references notes and footnotes which provide explanatory material. These notes and footnotes (excluding those in tables and figures) shall not be considered requirements of the standard.

## 2. Referenced Documents

2.1 *ASTM Standards:*<sup>2</sup>

<sup>1</sup> This test method is under the jurisdiction of ASTM Committee E05 on Fire Standards and is the direct responsibility of Subcommittee E05.11 on Fire Resistance. Current edition approved Jan-April 1, 2011. Published February-April 2011. Originally approved in 1981. Last previous edition approved in 2010 as E814 – 10.1. DOI: 10.1520/E0814-11A.

<sup>2</sup> For referenced ASTM standards, visit the ASTM website, www.astm.org, or contact ASTM Customer Service at service@astm.org. For *Annual Book of ASTM Standards* volume information, refer to the standard's Document Summary page on the ASTM website.

E119 Test Methods for Fire Tests of Building Construction and Materials

E176 Terminology of Fire Standards

E2226 Practice for Application of Hose Stream

2.2 Other Documents:

ANSI/UL 1479 Standard for Fire Tests of Through-Penetration Firestops

### 3. Terminology

3.1 Definitions:

3.1.1 For definitions of terms used in this test method refer to Terminology E176.

3.2 Definitions of Terms Specific to This Standard:

3.2.1 *firestop system, n*—a specific combination of penetrating item or items, the specific construction that is penetrated, and the materials or devices, or both, that seal the opening provided to accommodate one or more items that penetrate into or through a fire-resistance rated assembly.

3.2.1.1 *Discussion*—The materials and devices used to seal the opening around penetrating items are sometimes referred to as “firestops.” Note that it is not “firestops” that are tested by this standard, but rather “firestop systems.” Due to the complex interaction during a fire between the penetrant, the penetrated assembly, the materials and/or devices used to seal the penetration, and the specific size and shape of the opening, it is not possible to simply test the “firestop” to develop fire resistance data.

3.2.2 *membrane-penetration firestop system, n*—a firestop system that seals the opening provided to accommodate one or more items that penetrate the membrane on only one side of a fire-resistance rated assembly.

3.2.2.1 *Discussion*—Examples of penetrating items include cables, conduits, ducts, pipes, and electrical boxes.

3.2.3 *test assembly*—the wall or floor that is part of the firestop system being tested into which the test specimen(s) is (are) mounted or installed.

3.2.4 *test specimen*—the penetrating item or items and the materials or devices, or both, that seal the opening in the firestop system being tested.

3.2.5 *through-penetration firestop system, n*—a firestop system that seals the opening around penetrating items that pass through the entire fire-resistance rated assembly.

3.2.5.1 *Discussion*—Examples of penetrating items include cables, cable trays, conduits, ducts, and pipes.

### 4. Summary of Test Method

4.1 This method of testing through-penetration firestop systems exposes firestop systems to a standard temperature-time fire, and to a subsequent application of a hose stream.

4.2 Ratings are established on the basis of the period of resistance to the fire exposure, prior to the first development of through openings, flaming on the unexposed surface, limiting thermal transmission criterion, and acceptable performance under application of a hose stream.

### 5. Significance and Use

5.1 This test method is used to determine the performance of a firestop system with respect to exposure to a standard time-temperature fire test and a hose stream test. The performance of a firestop system is dependent upon the specific assembly of materials tested including the number, type, and size of penetrations and the floors or walls in which it is installed.

5.2 Two ratings shall be established for each firestop system. An *F* rating shall be based upon flame occurrence on the unexposed surface, while the *T* rating shall be based upon the temperature rise as well as flame occurrence on the unexposed side of the firestop system. These ratings, together with detailed performance data such as the location of through-openings and temperatures of penetrating items are intended to be one factor in assessing performance of firestop systems.

### 6. Control of Fire Tests

6.1 *Time-Temperature Curve*—The fire environment within the furnace shall be in accordance with the standard time-temperature curve shown in Fig. 1. The points on the curve that determine its character are:

Ambient at 0 min  
1000°F (538°C) at 5 min  
1300°F (704°C) at 10 min  
1550°F (843°C) at 30 min  
1700°F (927°C) at 60 min  
1850°F (1010°C) at 120 min  
2000°F (1093°C) at 240 min  
2300°F (1260°C) at 480 min or over

6.2 *Furnace Temperatures*:

6.2.1 The temperature fixed by the curve shall be the average temperature obtained from the readings of thermocouples symmetrically disposed and distributed within the test furnace to show the temperature near all parts of the assembly. Use a minimum of three thermocouples, with not fewer than five thermocouples per 100 ft<sup>2</sup> (9.29 m<sup>2</sup>) of floor surface, and not fewer than nine thermocouples per 100 ft<sup>2</sup> of wall specimen surface.

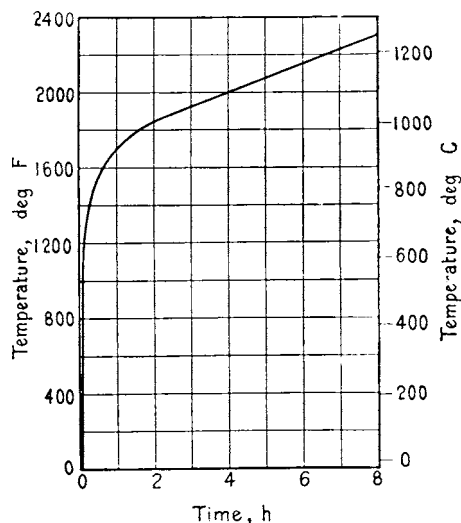

NOTE—For a closer definition of the temperature-time curve, see Annex A1.

FIG. 1 Temperature-Time Curve

6.2.2 Enclose the thermocouples in sealed protection tubes of such materials and dimensions that the time constant of the protected thermocouple assembly lies within the range (see Note 1) from 300 to 400 s. The exposed length of the pyrometer tube and thermocouple in the furnace chamber shall be not less than 12 in. (300 mm). Use of other types of protection tubes or pyrometers shall be acceptable provided that temperature measurements obtained in accordance with Fig. 1 are within the limit of accuracy that applies for furnace temperature measurements.

NOTE 1—A typical thermocouple meeting these time-constant requirements may be fabricated by fusion-welding the twisted ends of No. 18 B and S gage (0.040 in.) (1.02 mm) Chromel-Alumel wires, mounting the leads in porcelain insulators and inserting the assembly so the thermocouple bead is 0.50 in. (13 mm) from the sealed end of a standard weight, nominal 1/2-in. iron, steel, or Inconel pipe. (Inconel is a trademark of Inco Alloys, Inc., 3800 Riverside Dr., P.O. Box 1958, Huntington, WV 25720.) The time constant for this and for several other thermocouple assemblies was measured in 1976. The time constant may also be calculated from knowledge of its physical and thermal properties. See Research Report RR:E05-1001, available from ASTM Headquarters.

6.2.3 For floors, place the junction of the thermocouples 12 in. (300 mm) away from the exposed face of the assembly. In the case of walls, place the thermocouples 6.0 in. (150 mm) away from the exposed face.

6.2.4 Read the temperature at intervals not exceeding 5 min during the first 120 min. Thereafter, the intervals shall not exceed 10 min.

6.2.5 The accuracy of the furnace control shall be such that the area under the temperature-time curve, obtained by averaging the results from the pyrometer or thermoelectric device readings, is within 10 % of the corresponding area under the standard temperature-time curve shown in Fig. 1 for fire tests of 60 min or less duration; within 7.5 % for those over 60 min and not more than 120 min; and within 5 % for tests exceeding 120 min in duration.

### 6.3 Unexposed Surface Temperatures :

6.3.1 Measure temperatures on the surface of the materials, devices, or both, that are used to seal the opening in the test assembly.

6.3.2 Measure the temperature of the test assembly.

6.3.3 Measure temperature at each of the locations on the unexposed surface of the penetrating item and floor or wall assembly as shown in Fig. 2.

6.3.4 For tests of membrane penetration firestop systems, in addition to the requirements of 6.3.3, measure temperature at each of the locations on the non-fire side of the test assembly as shown in Fig. 3 for test assemblies that include membrane penetrations on only one face of the test assembly, or as shown in Fig. 4 for test assemblies that include conditions representative of both sides of the membrane penetration on one surface of the wall.

6.3.4.1 Discussion—The area in which thermocouples “G” are located, as shown in Fig. 3 and Fig. 4, is the perpendicular projections of the test assembly opening area on the non-fire side of the un-penetrated membrane.

6.3.5 Additional temperature measurements shall be made at the discretion of the testing agency to obtain representative information on the performance of the firestop systems.

6.3.6 For the purpose of obtaining supplementary information during tests of membrane penetrations, the temperature inside of each wall cavity having a membrane penetration shall be measured using one or more thermocouples. Such thermocouples shall be located  $3 \pm 0.25$  in. ( $76 \pm 6$  mm) vertically from the inside top of the wall cavity, and each located  $3 \pm 0.25$  in. ( $76 \pm 6$  mm) in. horizontally from the penetration centerline. Wires for the thermocouples shall be routed so as not to impact the fire performance measurements that are made on the non-fire side membrane.

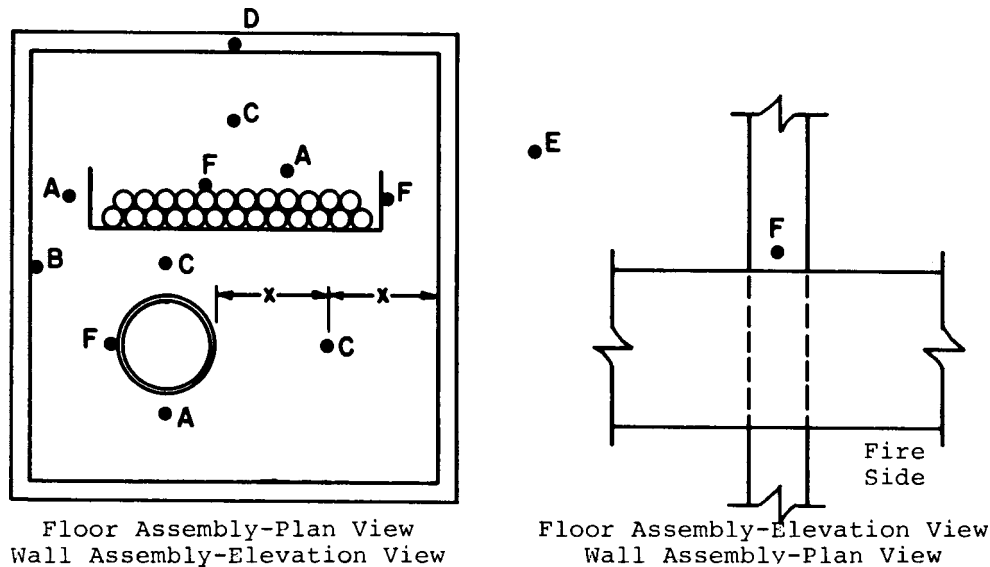

**Legend:**

- A—At a point on the surface of the materials or devices, or both, that seal the opening 1 in. (25 mm) from one through-penetrating item for each type of penetrating item employed in the field of the materials or devices, or both, that seal the opening. If the grouping of penetrating items through the test sample prohibits placement of the thermocouple pad, the thermocouple shall not be required.
- B—At a point at the periphery on the surface of the materials or devices, or both, that seal the opening.
- C—At a minimum of three points on the surface of the materials that seal the opening, approximately equidistant from a penetrating item or group of penetrating items in the field of the materials that seal the opening and the periphery.
- D—At one point on any frame that is installed about the perimeter of the opening.
- E—At one point on the unexposed surface of the wall or floor that is a minimum of 12 in. (305 mm) from any opening.
- F—At one point on each type of through-penetrating item. If the through-penetrating item is insulated or coated on the unexposed side, the thermocouple shall be located on the exterior surface of the insulation or coating. If the coating or insulation does not extend the full length of the penetrating item on the unexposed side, an additional thermocouple shall be installed on the penetrating item 1.0 in. (25.4 mm) beyond the termination of the insulation or coating.

**FIG. 2 Temperature Measurement Locations**

6.3.7 Temperature measurements shall be made with thermocouples placed under flexible pads specified in Annex A2. The pads shall be held firmly against the surface and shall fit closely about the thermocouples. The thermocouple junction shall be located under the center of the pads. The thermocouple leads under the pads shall be not heavier than No. 18 B and S gage (0.040 in.) (1.02 mm) and shall be electrically insulated with heat-resistant moisture-resistant coverings.

6.3.8 For tests of membrane penetration firestop systems, the pads placed over thermocouples used to measure the non-fire side wall temperature at the top of the wall cavity (position H in Fig. 3 and Fig. 4) shall have the properties specified in Annex A2, except that they shall have a length and width of  $6.00 \pm 0.04$  in. ( $152 \pm 1$  mm).

6.3.8.1 *Discussion*—The use of thermocouple pads with dimensions of 6 by 6 in. (152 by 152 mm) for position H in Fig. 3 provides consistency with Test Method E119, which also uses that size of thermocouple pad. This thermocouple pad will not be constrained by limitations of space, as other thermocouple positions are likely to be.

6.3.9 For a through-penetration firestop system, measure temperatures of each type and size of penetrating item with at least one thermocouple located 1.0 in. (25.4 mm) from the unexposed surface of the material, device, or both, that is (are) used to seal the opening in the test assembly. The thermocouple bead shall be held firmly against the penetrating item. The thermocouple leads shall not be heavier than No. 22 B and S gage (0.025 in.) (0.635 mm) and shall be electrically insulated with heat-resistant and moisture-resistant coverings. The pads as described above shall be held firmly against the penetrating item and shall fit closely about the thermocouples.

6.3.10 Temperature readings shall be taken at intervals not exceeding 15 min until a reading exceeding 212°F (100°C) has been obtained at any one point. Thereafter, at the discretion of the testing body, the readings shall be taken more frequently, but the intervals need not be less than 5 min.

**6.4 Differential Pressure:**

6.4.1 The pressure differential between the exposed and unexposed surfaces of the test assembly, as defined in 3.2.3, shall be measured at two points 0.78 in. (20 mm) from the exposed surface of the test assembly as follows:

6.4.1.1 *Walls*—At two points along the vertical center line. The two points shall be separated by a vertical distance that is equal to or greater than one-half of the height of the test assembly.

6.4.1.2 *Floors*—Two points along the longitudinal center line at a distance of  $\frac{1}{4} \pm \frac{1}{8}$  from the center of the floor where  $L$  equals the length of the floor.

6.4.2 The pressure-measuring probes shall be a Tee-shaped probe or a tube probe and shall be manufactured from stainless steel or other suitable material.

6.4.3 Measure the pressure by means of a manometer or equivalent transducer. The manometer or transducer shall be capable

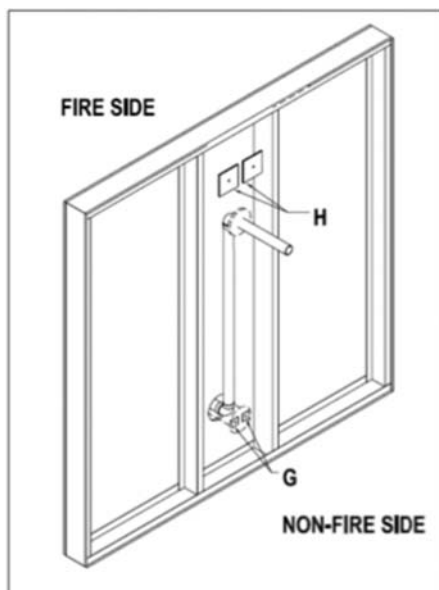

**Legend:**

**G**—At a minimum of two points on the non-fire side surface, within the area that is a parallel projection onto the non-fire side of the hole made in the floor or wall assembly to accommodate the membrane penetration. When the area of the projection on the non-fire side is too small to permit the placement of two thermocouples, one thermocouple shall be used, located at the center of the projected area.

**H**—At two points on the non-fire side surface, located less than 3 in. (76 mm) vertically from the inside top of the wall cavity, and each located less than 3 in. horizontally from the penetration centerline.

**FIG. 3 Membrane Penetration Firestop System Temperature Measurement Locations for Test Assemblies that Include Membrane Penetrations on Only One Face of the Test Assembly**

of reading 0.01-in. H<sub>2</sub>O (2.5-Pa) increments with a measurement precision of 0.005 in. H<sub>2</sub>O (1.25 Pa).

6.4.4 The furnace shall be controlled such that the differential pressure between the exposed and the unexposed surfaces of the test assembly complies with either 6.4.4.1 or 6.4.4.2.

6.4.4.1 *Standard Pressure Condition*—Except for the first 10 min. of the test, the furnace pressure shall be at least 0.01 in. wg (2.5 Pa) greater than the pressure on the unexposed side of the test assembly at the following locations:

- (1) *Walls*—At the lowest elevation of the test specimen (see Note 2).
- (2) *Floors*—At the location of the pressure-measuring probes.

NOTE 2—A supplementary pressure probe, in addition to the two probes specified in 6.4.1.1, may be used to determine compliance with this requirement.

6.4.4.2 *Unique Pressure Condition*—The differential pressure shall be specified by the test sponsor. The furnace shall be controlled such that the specified differential pressure is maintained throughout the duration of the test, excluding the first 10 min., within 20 % of the specified pressure.

**7. Test Specimen**

**7.1 Construction and Size:**

7.1.1 The construction of the test firestop systems shall be of sufficient size and include all conduits, pipes, cables (jacket types, sizes, conductor types, percent fills), required supports, or other through-penetrating items so as to produce a representative firestop system for which evaluation is being sought. Install and test firestop systems for each construction type for which ratings are being sought.

7.1.2 Install through-penetrating items so that they extend 12 in. (300 mm) on the exposed side and 36 in. (900 mm) on the unexposed side unless either or both of these extensions are not typical of actual field installations. In such cases, the installation shall be representative of actual field installations. Through-penetrating items on the exposed side of the test assembly shall be exposed to the furnace temperatures. Support the extended portion of through-penetrating items on the unexposed side so as to minimize relative movement between the through-penetrating item and the restraining frame in which the test assembly is mounted. Cap or otherwise seal the individual ends of through-penetrating items on the exposed side. When the through-penetrating item is a closed system that in actual field practice is not vented or open to the atmosphere, the through-penetrating item shall be capped or sealed on the unexposed side. In such cases, a pressure relief hole shall be provided through the cap or seal on the unexposed side. Otherwise, through-penetrating items shall not be capped or sealed on the unexposed side.

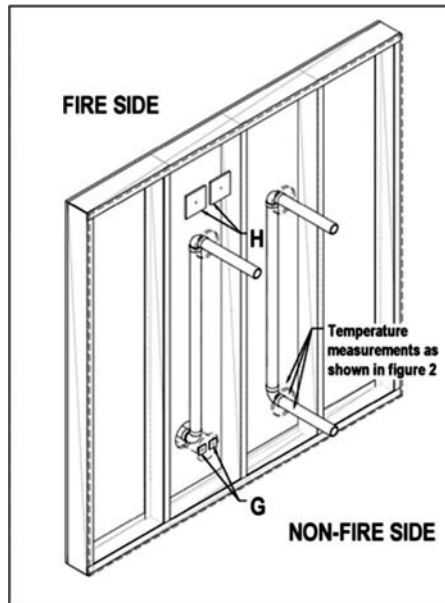

*Legend:*

G—At a minimum of two points on the non-fire side surface, within the area that is a parallel projection onto the non-fire side of the hole made in the floor or wall assembly to accommodate the membrane penetration. When the area of the projection on the non-fire side is too small to permit the placement of two thermocouples, one thermocouple shall be used, located at the center of the projected area.

H—At two points on the non-fire side surface, located less than 3 in. (76 mm) vertically from the inside top of the wall cavity, and each located less than 3 in. horizontally from the penetration centerline.

**FIG. 4 Membrane Penetration Firestop System Temperature Measurement Locations for Test Assemblies that Include Conditions Representative of Both Sides of the Membrane Penetration on One Surface of the Assembly**

7.1.3 The periphery of the materials or devices, or both, that seal the opening in the test assembly shall not be closer than 1½ times the thickness of the test assembly or a minimum of 12 in. (300 mm) to the furnace edge, whichever is greater (see Note 3).

NOTE 3—The distance between the periphery of the materials or devices, or both, that seal the opening in the test assembly and the furnace edge may be reduced if the testing agency demonstrates and reports that the edge effects do not affect the results.

7.2 For wall membrane penetration tests, any linear penetrating item shall be routed vertically up from the membrane penetration. The linear penetrating item shall exit the wall cavity  $9 \pm 0.5$  in. ( $229 \pm 13$  mm) below the top-most element of the test assembly frame through a hole in the wall surface having an annular space of 0.5 in. (13 mm) or less. The annular space of that hole shall be sealed with tightly packed ceramic fiber. Capping of the penetrating item on both the fire side and non-fire side shall be as specified in 7.1.2. Length of the penetrant exposed to furnace conditions on the fire side shall be a minimum of 12 in. (305 mm).

NOTE 4—Although details are provided here to describe how membrane penetrations by linear penetrating items (for example, cables, pipes, conduit) shall be installed in the test assembly, most membrane penetrations of interest in the built environment will be discrete items. Examples of such discrete items include recessed boxes for electrical, water or gas piping connections, recessed wall-mounted equipment cabinets, and recessed electrical equipment panels. Such items would normally not include any elongated parts whose extreme ends would need to be routed out near the top of the non-fire side of the test assembly.

## 8. Protection and Conditioning

8.1 Prior to fire test, condition the firestop system to provide a moisture condition representative of that existing in similar construction in buildings. For the purposes of standardization, this condition is established at equilibrium resulting from drying in an ambient atmosphere of 50 % relative humidity at 73°F (23°C). However, with some firestop systems it is difficult or impossible to achieve such uniformity. Therefore, firestop systems shall be eligible for testing when their dampest portion has achieved a moisture content corresponding to drying to equilibrium with air in the range from 50 to 75 % relative humidity at  $73 \pm 5^\circ\text{C}$  ( $23 \pm 3^\circ\text{C}$ ). If the firestop systems dried in a heated building fail to meet these requirements after a 12-month conditioning period, or if the nature of the construction is such that drying of the interior of the test assembly or the interior of the material used to seal the opening will be prevented by hermetic sealing, these requirements shall be waived, except as to attainment of the required strength as described in 9.1, and the firestop system is tested in the condition in which it then exists.