



Designation: C756 – 87 (Reapproved 2011)^{ε1}

Standard Test Method for Cleanability of Surface Finishes¹

This standard is issued under the fixed designation C756; the number immediately following the designation indicates the year of original adoption or, in the case of revision, the year of last revision. A number in parentheses indicates the year of last reapproval. A superscript epsilon (ϵ) indicates an editorial change since the last revision or reapproval.

^{ε1} NOTE—Test Method was corrected editorially in 2011

INTRODUCTION

This test provides a procedure to quantify the cleanability of acid-resistant porcelain enamel using a fluorescent water-soluble soil in agent, a reproducible machine-wiping technique, and a means of measuring the amount of residual soil by fluorescence.

1. Scope

1.1 This test method covers the numerical evaluation of the ease or difficulty of cleaning soiled surface finishes. This test method is applicable to all surface finishes not affected by water.

1.2 Values given in SI units are to be regarded as the standard. Inch-pound units are provided for information only.

1.3 *This standard does not purport to address all of the safety concerns, if any, associated with its use. It is the responsibility of the user of this standard to establish appropriate safety and health practices and determine the applicability of regulatory limitations prior to use.*

2. Referenced Documents

2.1 *ASTM Standards:*²

C282 Test Method for Acid Resistance of Porcelain Enamels (Citric Acid Spot Test)

C614 Test Method for Alkali Resistance of Porcelain Enamels

3. Summary of Test Method

3.1 The test method consists of applying an exact amount of a fluorescent water-soluble soiling agent to a specimen surface and then cleaning the surface with a reproducible machine-wiping technique. The soil remaining on the specimen after wiping is extracted with a water solvent and the fluorescence of

the solution measured. A standard reference surface is treated in a similar manner. The cleanability index of the surface under test is expressed as the ratio of the fluorescence of the solutions extracted from the test surface and from the standard reference surface. Cleanability indexes greater than 1.0 indicate that the test surface is more difficult to clean than the standard reference surface, while indexes less than 1.0 indicate that the test surface is more easily cleanable than the standard of comparison.

3.2 The soiling agent used consists of polyethylene glycol, a black dye, and a fluorescent tracer, each of which is readily water soluble.

4. Significance and Use

4.1 This test method was developed to guide the user in selecting a finish coating or material that is resistant to soiling in a particular application.

4.2 The numerical values derived by this test method enables the user to rank finish coatings and materials in regard to soil retention or ease of soil removal.

5. Apparatus

5.1 *Motor-Driven Lapping Plate*, 203-mm (8-in.) diameter, speed 163 r/min.³

5.2 *Automatic Polishing Unit*, 11-s cycle, adjustable to 48-mm (1⁷/₈-in.) stroke.⁴

5.3 *Hypodermic Syringe*, glass, 2-mL capacity, without needle.

¹ This test method is under the jurisdiction of ASTM Committee B08 on Metallic and Inorganic Coatings and is the direct responsibility of Subcommittee B08.12 on Materials for Porcelain Enamel and Ceramic-Metal Systems.

Current edition approved April 1, 2011. Published April 2011. Originally approved in 1973. Last previous edition approved in 2006 as C756 – 87 (2006). DOI: 10.1520/C0756-87R11E01.

² For referenced ASTM standards, visit the ASTM website, www.astm.org, or contact ASTM Customer Service at service@astm.org. For *Annual Book of ASTM Standards* volume information, refer to the standard's Document Summary page on the ASTM website.

³ Suitable lapping plates are available from Buehler Ltd., 2120 Greenwood St., Evanston, IL 60204, Struers, Inc., 20102 Progress Drive, Cleveland, OH, 44136; or other Metallurgical Supply Sources.

⁴ An Olsen "S.M." Automatic Polisher has been found suitable and is available under the code name OLPOL from Struers, Inc., 20102 Progress Drive, Cleveland, OH 44136.

- 5.4 *Repeating Pipet*, 0.025 mL (25 µl) capacity.
- 5.5 *Repeating Pipet*, 10-mL capacity.
- 5.6 *Desiccator* approximately 254 mm (10 in.) diameter.
- 5.7 *Cleaning Head*, brass, 57 mm (2¼ in.), with worm-driven hose clamp for attachment of cleaning tissues (Fig. 1).

6. Reagents and Materials

- 6.1 *Cleaning Tissues*, approximately 127 by 229 mm (5 by 9 in.).⁷
- 6.2 *Potassium Carbonate*.
- 6.3 *Polyethylene Glycol*, 400.

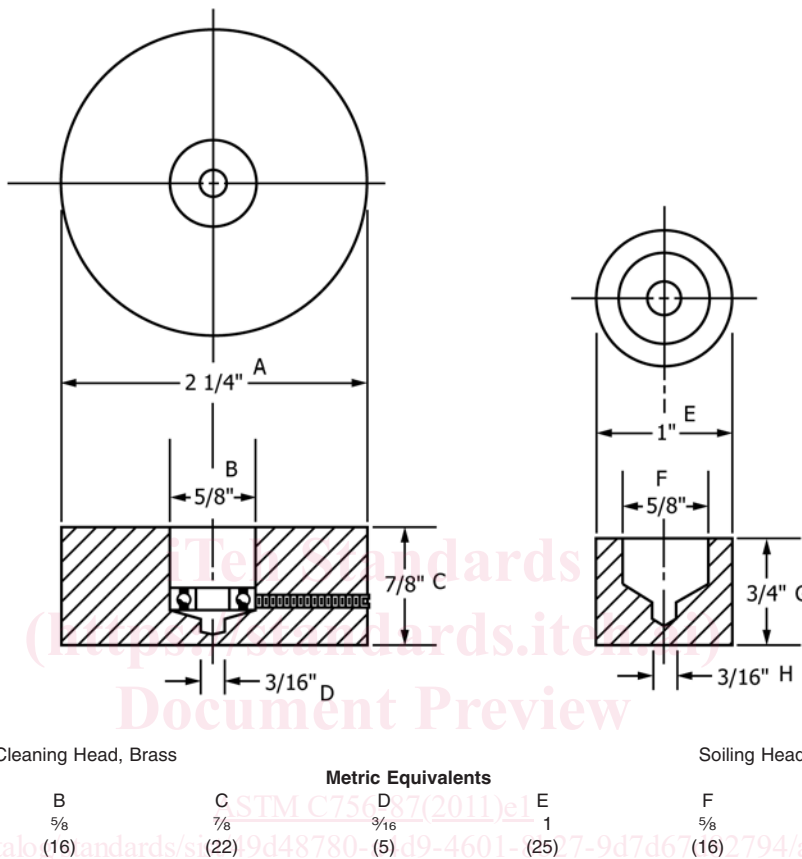

FIG. 1 Cleaning and Soiling Heads

5.8 *Soiling Head*, brass, 25 mm (1 in.) diameter, with 25-mm (1-in.) diameter facing of polytetrafluoroethylene attached with a water-proof household cement (Fig. 1).

5.9 *Extraction Cell*, fitted with a fluorosilicone O-ring, size 3.2 by 57 mm (1/8 by 2¼ in.) (Fig. 2).⁵

5.10 *Fluorometer*, for measuring the fluorescence of solutions.⁶

5.11 *0.9 Neutral Density Filter*, 50.8 by 50.8 mm (2 by 2 in.) glass mounted (transmission 12.5 %).

5.12 *Beakers*, borosilicate, 100-mL capacity.

6.4 *Uranine*, water-soluble, USP.⁸

6.5 *Keco Acid Black*, B(F101).⁹

6.6 *Ethyl Alcohol*.

6.7 *Mild Household Detergent*, liquid.

7. Test Specimens

7.1 The preferred specimen size is 114 mm (4½ in.) square, but any other size or shape may be used provided it can be rotated on the lapping wheel and the smaller dimension is between 102 and 127 mm (4 and 5 in.). Sharp or jagged edges shall be filed or honed to prevent snagging of the cleaning tissues during the mechanical cleaning process.

7.2 Twelve specimens are required to evaluate the cleanliness index, that is, six of the candidate surface, and six of a

⁵ O-rings must be fluorosilicone polymer; consult Precision Associates, 742 N. Washington Ave., Minneapolis, MN 55401; Parker Seal Co., 10567 W. Jefferson Blvd., Culver City, CA 90230; & B. W. Rogers (Parker Dis.) 1000 Brookpark Rd., Cleveland, OH 44109. Also see other sources in Thomas Register under SEALS: "O" RINGS. A suitable device for clamping the cell to a specimen is shown in Fig. 3 and Fig. 5.

⁶ Turner Fluorometer, Model 111 (Turner 111-003) available from Curtin Matheson Scientific, Inc., 10727 Tucker St., Beltsville, MD 20705, Sequoia-Turner Dial Model 111, Fisher Scientific Co., 711 Forbes Ave., Pittsburg, PA 15219, and other principal cities for both.

⁷ Cel-Fibe Wipes, Type 1745 or equivalent.

⁸ Uranine is the sodium salt of fluorescein, C₂₀H₁₀O₅Na₂.

⁹ A water-soluble fabric dye used principally for nylon, silk, and wool; available from Keystone Aniline and Chemical Co., 321 N. Loomis, Chicago, IL 60607.

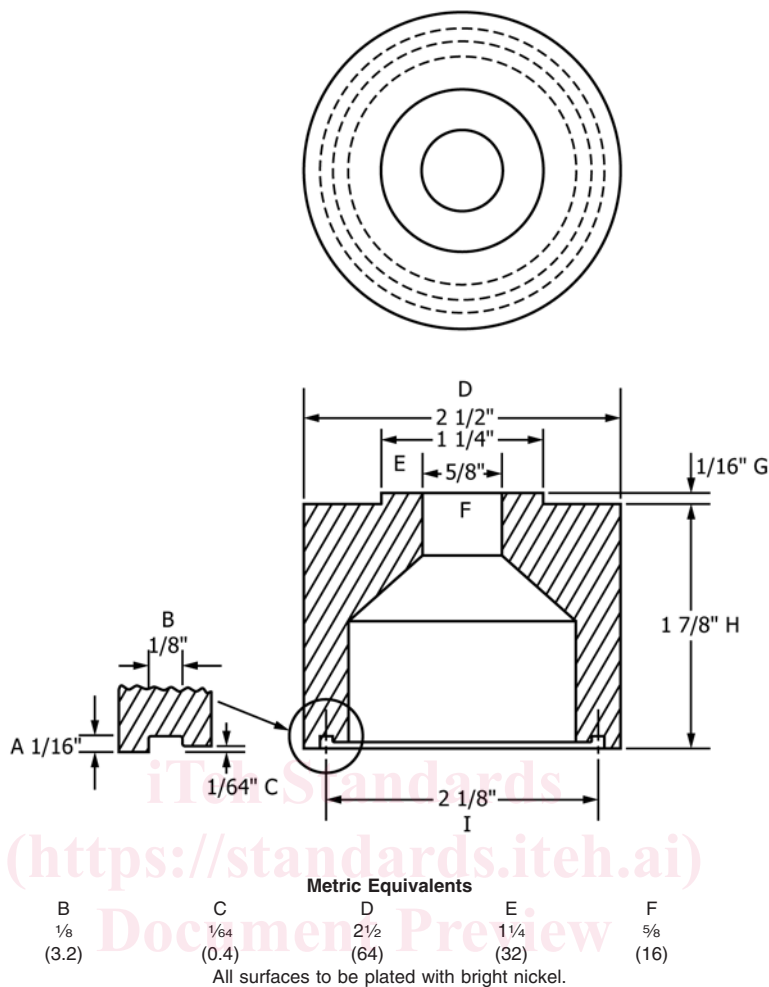

FIG. 2 Brass Extraction Cell

porcelain enamel standard reference surface for cleanability. Porcelain enamel specimens are not damaged by the cleanability test and may be cleaned and reused many times. Specimens have been reused as many as 50 times without damage or solid buildup.

NOTE 1—The porcelain enamel covercoat used to coat the standard reference surface shall have the following characteristics: Acid Resistance: AA (Test Method C282) Alkali Resistance: Maximum 1.55 mg/cm wt. loss (Test Method C614).

8. Preparation of Standard Soil

8.1 The soiling agent shall consist of the following:

Ingredient	Weight %
Polyethylene glycol	98
Keco Acid Black B	1
Uranine, water-soluble	1

8.2 The uranine shall be added to the polyethylene glycol in food blender and mixed by alternate periods of mixing and standing until the crystalline uranine appears to be completely dissolved in the glycol. The black dye which obscures all else

shall be added last and thoroughly mixed in the blender. This soiling agent shall be stored in a tightly stoppered glass bottle at least overnight before use.

9. Procedure

9.1 *Specimen Pretreatment*—Scrub the specimens with a cellulose sponge wet with a 1 % solution of a mild household detergent at room temperature. Rinse in turn with tap water, distilled water, and ethyl alcohol, and allow to dry in a near-vertical position at room temperature. Store the washed and dried specimens overnight in a desiccator charged with a saturated solution of potassium carbonate.

9.2 *Conditioning of Cleaning Tissues*—Cut a supply of tissues ample for use in specimen cleaning treatment in the following paragraph into approximately 102-mm (4-in.) squares and store overnight, before use, in a desiccator charged with a saturated solution of potassium carbonate (relative humidity approximately 45 %). Allow the tissues to remain in the desiccator until just prior to use.

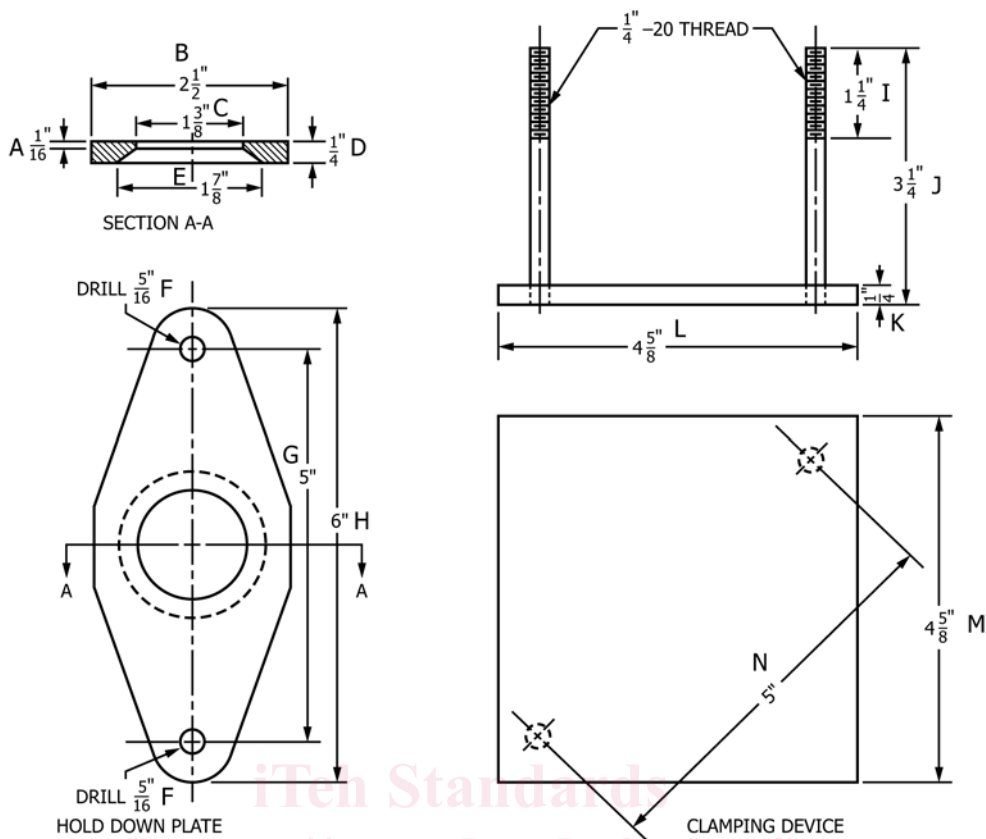

	A	B	C	D	E	F	G	H	I	J	K	L	M	N
in.	1/16	2 1/4	1 3/8	1/4	1 7/8	5/16	5	6	1 1/4	3 3/4	1/4	4 5/8	4 5/8	5
(mm)	(1.6)	(64)	(35)	(6.4)	(47)	(8)	(127)	(152)	(32)	(83)	(6.4)	(117)	(117)	(127)

FIG. 3 Device for Clamping Extraction Cell to Specimen

ASTM C756-87(2011)e1

9.3 Soiling and Cleaning Treatments:

9.3.1 Lay out six specimens face up on a table. Homogenize the soiling agent by up-ending several times before use. Fill the hypodermic syringe with no needle attached with the soiling agent by withdrawing the plunger. Expel this charge of soil back into the soil bottle. Then fill the syringe again. Wipe the tip of the syringe with a cleaning tissue and expel several drops into the soil bottle. Then, without rewiping the tip, hold the syringe vertically over a specimen and discharge one drop near the center of each of the six specimens. Center the first specimen on the lapping wheel and hold it in place by means of adhesive tape across the specimen corners. Place the polytetrafluoroethylene-faced soiling head on the soil, and engage the spindle (Fig. 4) of the polishing unit. Operate the lapping wheel and the polishing unit for 1 min to distribute the soil over the central portion of the specimen (Fig. 5). Remove the soiling head and clean it with tissue for reuse. Adjust the spindle so that it rests over the center of the soil spot. Prepare two cleaning heads 57 mm (2 1/4 in.) diameter) by covering with four thicknesses of cleaning tissues clamped smoothly in place. With the repeating pipet expel exactly 0.021 mL of distilled water at the center of the tissue on the first cleaning head.

9.3.2 Immediately place the cleaning head with tissue side against the soiled specimen, engage the spindle, and operate for

22 s (so that it will stop as well as start at the center of the specimen). Remove the cleaning head without sliding motion. Repeat the cleaning operation with the second tissue-covered head, using the same amount of distilled water and for the same 22-s period.

9.3.3 Store the first soiled and cleaned specimen in a near vertical position in a rack while applying exactly the same series of soiling and cleaning treatments to the five remaining specimens.

9.4 Water Extraction of the Soil Retained—Remove the small, often nonvisible, amounts of soil from the central portion of the soiled and cleaned specimens with 10 mL of distilled water in the O-ring sealed extraction cell by the following sequence of operations within 30 min after soiling; place the first soiled and cleaned specimen, face up, in the center of the cell clamping frame. Place a clean and dry extraction cell (Fig. 2) on the center of the specimen so that the O-ring defines the area to be extracted (Fig. 5). Clamp the cell in the frame with a light pressure from the wing nuts; introduce 10 mL of distilled water with the 10-mL repeating pipet, swirl the water in the cell momentarily and let stand for 3 min, give the solution in the cell another swirl and pour out into a clean and dry 100 mL beaker; transfer a portion of the extract to a