

---

# International Standard



# 2705

---

INTERNATIONAL ORGANIZATION FOR STANDARDIZATION • МЕЖДУНАРОДНАЯ ОРГАНИЗАЦИЯ ПО СТАНДАРТИЗАЦИИ • ORGANISATION INTERNATIONALE DE NORMALISATION

---

## Road vehicles — Spark plugs M 12 × 1,25 with flat seating and their cylinder head housing

*Véhicules routiers — Bougies d'allumage M 12 × 1,25 à siège plat et leur logement dans la culasse*

Third edition — 1982-12-01

**iTeh STANDARD PREVIEW**  
**(standards.iteh.ai)**

[ISO 2705:1982](https://standards.iteh.ai/catalog/standards/sist/3aba658d-b11f-43ab-96e9-5d7c311e3d16/iso-2705-1982)

<https://standards.iteh.ai/catalog/standards/sist/3aba658d-b11f-43ab-96e9-5d7c311e3d16/iso-2705-1982>

---

UDC 621.43.045

Ref. No. ISO 2705-1982 (E)

Descriptors : road vehicles, motor vehicles, internal combustion engines, ignition systems, spark plugs, dimensions, dimensional tolerances.

Price based on 4 pages

## Foreword

ISO (the International Organization for Standardization) is a worldwide federation of national standards institutes (ISO member bodies). The work of developing International Standards is carried out through ISO technical committees. Every member body interested in a subject for which a technical committee has been set up has the right to be represented on that committee. International organizations, governmental and non-governmental, in liaison with ISO, also take part in the work.

Draft International Standards adopted by the technical committees are circulated to the member bodies for approval before their acceptance as International Standards by the ISO Council.

International Standard ISO 2705 was developed by Technical Committee ISO/TC 22, *Road vehicles*, and was circulated to the member bodies in January 1981.

It has been approved by the member bodies of the following countries :

Australia	Iran	South Africa, Rep. of
Austria	Italy	Spain
Belgium	Korea, Dem. P. Rep. of	Sweden
Brazil	Korea, Rep. of	Switzerland
China	Mexico	United Kingdom
Egypt, Arab Rep. of	Netherlands	USA
France	New Zealand	USSR
Germany, F.R.	Romania	

The member body of the following country expressed disapproval of the document on technical grounds :

Japan

This third edition cancels and replaces the second edition (i.e. ISO 2705-1976).

# Road vehicles — Spark plugs M 12 × 1,25 with flat seating and their cylinder head housing

## 1 Scope

This International Standard specifies the main dimensional characteristics of a spark plug type used with spark ignition engines.

## 2 Field of application

The provisions of this International Standard apply to spark plugs M 12 × 1,25 with flat seating with normal or long reach, and to their cylinder head housing.

## 3 References

ISO 68, *ISO general purpose screw threads — Basic profile.*

ISO 261, *ISO general purpose metric screw threads — General plan.*

ISO 965/1, *ISO general purpose metric screw threads — Tolerances — Part 1 : Principles and basic data.*

ISO 965/3, *ISO general purpose metric screw threads — Tolerances — Part 3 : Deviations for constructional threads.*

## 4 Required characteristics

### 4.1 Terminals (see figure 3 and annex)

The preferred type is the solid post terminal.

The threaded terminal with nut is permitted (see annex).<sup>1)</sup>

Engine manufacturers are encouraged to introduce solid post terminals in practice.

## 4.2 Dimensions and thread (see figures 1 and 2)

### 4.2.1 Plug reach

Values in millimetres

Type of reach	A	B max.	Y
Normal reach	12,7 ± 0,2	19	11,7 ± 0,3
Long reach	19,0 ± 0,2	25	18,0 ± 0,3

### 4.2.2 Gasket

When the spark plugs have been tightened with a torque of 25 N·m (threads clean, smooth and dry), the gaskets shall be 1,0 to 1,6 mm in thickness. If the gaskets are of a different thickness, a corresponding adjustment to dimensions A, B and Y shall be made.

Non-captive gaskets may be used in special cases.

### 4.2.3 Thread

#### 4.2.3.1 Dimension limits

Values in millimetres

Dimension	Plug thread (on finished plug) 6e		Tapped hole in cylinder head 6H
	max.	min.	
Major diameter	max.	11,937	not specified
	min.	11,725	12,000
Pitch diameter	max.	11,125	11,368
	min.	10,993	11,188
Minor diameter	max.	10,404	10,912
	min.	10,181 *	10,647

\* With a root radius > 0,125 mm (0,1 P)

1) This permission will be re-examined in 5 years.

**4.2.3.2 Tolerance classes**

The tolerance classes of thread M 12 × 1,25 of finished spark plugs and of the corresponding tapped holes in the cylinder head are as follows :

- 6e for spark plugs (see note 2);
- 6H for tapped holes in the cylinder head.

**NOTES**

1 The threads M 12 × 1,25 of the spark plugs and the corresponding tapped holes in the cylinder head shall conform to ISO 68, ISO 261, ISO 965/1 and ISO 965/3.

2 In order that the spark plugs complying with this International Standard can be fitted in existing cylinder heads also in limiting cases, the value for the *upper limiting profile* of the minor diameter of the spark plug base has been slightly reduced with respect to the ISO value.

This maximum value of the minor diameter was calculated from a distance of  $H/6$  for the *upper limiting profile* instead of  $3H/16$  given in figure 6 of ISO 965/1, clause 10, according to the formula given below :

$$\begin{aligned} \text{Minor diameter max.} &= d_1 - e_s - 2(H/4 - H/6) \\ &= 10,647 - 0,063 - 0,180 \\ &= 10,647 - 0,243^* = 10,404 \end{aligned}$$

The value for the *basic profile* remains the same as for the ISO thread (10,647 - 0,063 = 10,584).

3 The initial clearance  $e = 0,063$  mm between the pitch diameters of the thread and of the tapped hole is intended to prevent the possibility of seizure, as a result of combustion deposits on the bare threads, when removing the spark plugs.

This clearance is also intended to enable spark plugs with threads in accordance with this International Standard to be fitted in existing tapped holes.

**4.3 Other dimensions of the spark plug and the housing in the cylinder head**

The other dimensions are indicated on figures 1, 2 and 3.

The contour of the insulator is optional, however, between the reference lines defined by the dimensions 29 and 33 mm, its largest diameter shall be  $10,5 \pm 0,3$  mm.

The Z length of the spark plug housing in the cylinder head shall be sufficient to ensure that the end of the spark plug thread does not project into the combustion chamber at any point when the gasket is tightened to maximum compression.

Details not specified are left to the manufacturer's choice.

**4.4 Installation tightening torque**

The installation torque values apply to new spark plugs without lubricant on the threads. If threads are lubricated, the torque value shall be reduced by approximately 1/3 to avoid overstressing.

The spark plugs shall be tightened with a torque of :

15 to 25 N·m in aluminium and cast iron cylinder heads.

NOTE — Engine manufacturers may specify a different torque for the first spark plug installation.

\* This value is given in ISO 965/3 for the minor diameter.

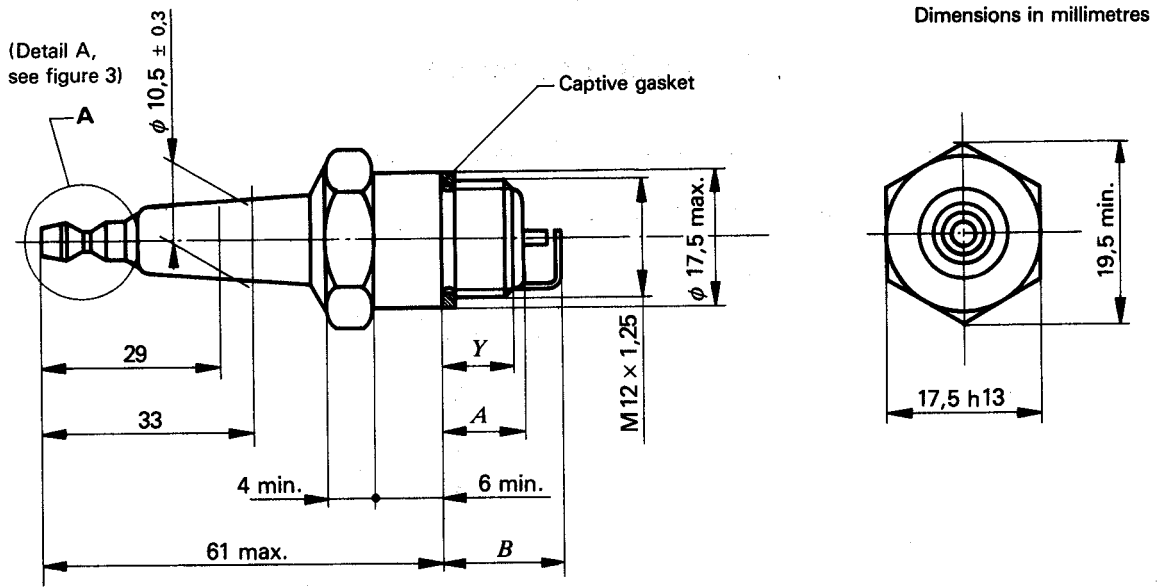

Figure 1 – Spark plug M 12 × 1,25 with flat seating

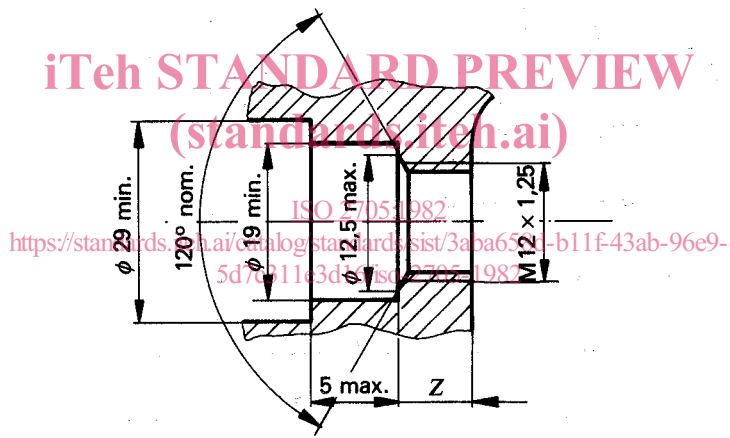

Figure 2 – Housing of the spark plug in the cylinder head

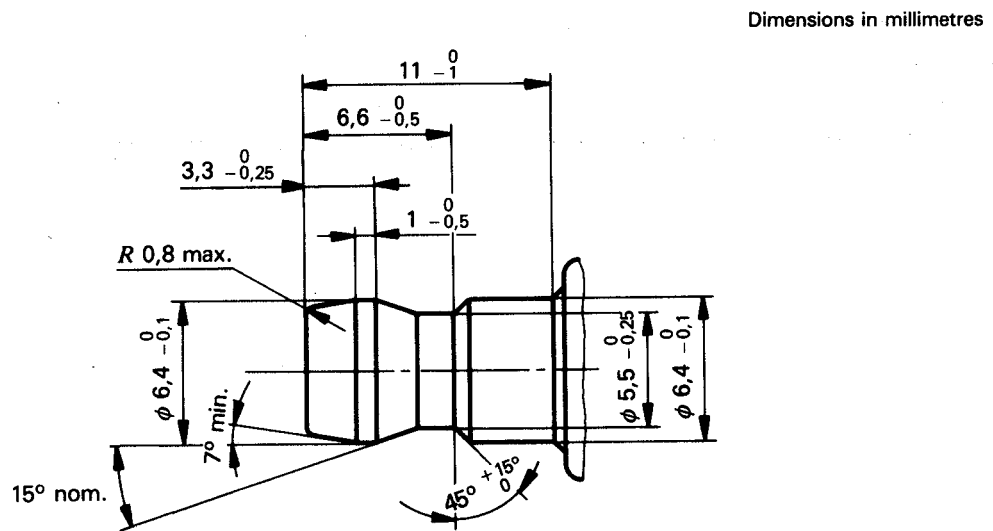

Figure 3 – Solid post terminal (detail A of figure 1)

## Annex

### Threaded terminal

The external dimensions of the nuts shall be the same as those for the solid post terminal.

The internal dimensions of the nuts are left to the manufacturer's choice.

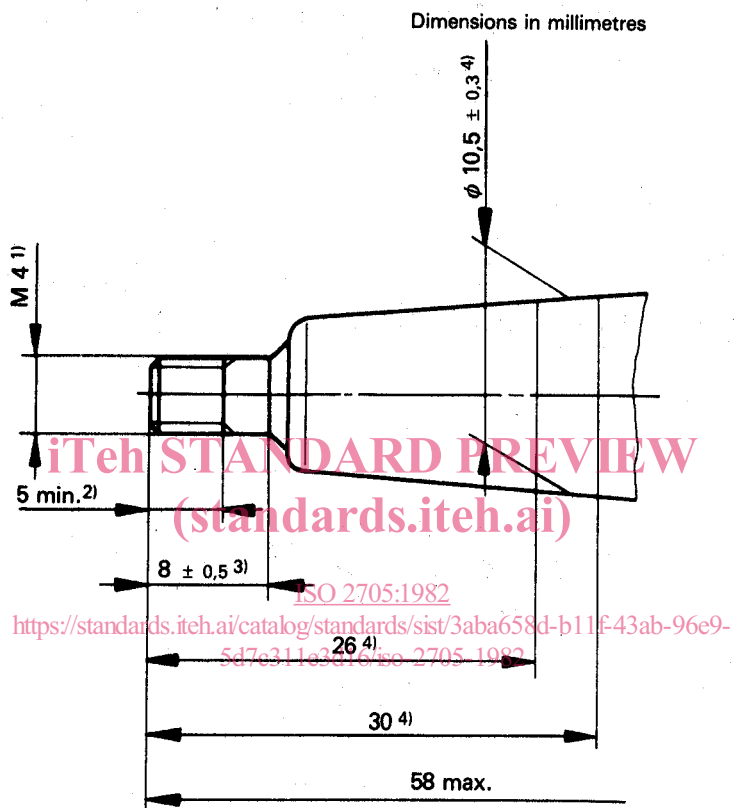

**Figure 4 – Threaded terminal**

- 1) 0,7 mm pitch complying with ISO 68 and with ISO 261.
- 2) Useful length of thread.
- 3) Cylindrical part.
- 4) The contour of the insulator is optional. However, between the reference lines defined by the dimensions 26 and 30 mm, its largest diameter shall be  $10,5 \pm 0,3$  mm.

**iTeh STANDARD PREVIEW**  
**(standards.iteh.ai)**

ISO 2705:1982

<https://standards.iteh.ai/catalog/standards/sist/3aba658d-b11f-43ab-96e9-5d7c311e3d16/iso-2705-1982>

**iTeh STANDARD PREVIEW**  
**(standards.iteh.ai)**

ISO 2705:1982

<https://standards.iteh.ai/catalog/standards/sist/3aba658d-b11f-43ab-96e9-5d7c311e3d16/iso-2705-1982>