



Standard Specification for Modular Gauge Boards¹

This standard is issued under the fixed designation F707/F707M; the number immediately following the designation indicates the year of original adoption or, in the case of revision, the year of last revision. A number in parentheses indicates the year of last reapproval. A superscript epsilon (ϵ) indicates an editorial change since the last revision or reapproval.

This standard has been approved for use by agencies of the U.S. Department of Defense.

1. Scope

1.1 This specification covers modular gauge boards for mounting 89-mm (3½-in.), 114-mm (4½-in.), 152-mm (6-in.), and 216-mm (8½-in.) dial size pressure gauges and dial thermometers for miscellaneous shipboard applications.

1.2 Gauge boards ordered under this specification are suitable for pressure gauges and dial thermometers with either turret or back flanged type cases and with either back or bottom connections (see [Appendix X1](#)).

1.3 Gauge mounting dimensions shall be in accordance with ANSI B 40.01

1.4 The values stated in SI units are to be regarded as the standard. The inch-pound values given in parentheses are for information only.

NOTE 1—Gauge boards covered by this specification are those normally supplied by the shipyard as opposed to the shipyard's equipment subcontractor.

2. Referenced Documents

2.1 Other Standards:

[B 40.1 Gauges, Pressure and Vacuum, Indicating Dial Type—Elastic Element](#)²

[Fed Spec. TT-P-645 Primer, Paint, Zinc-Chromate, Alkyd Type](#)³

[DoD-P-15328 Primer \(Wash\), Pretreatment \(Formula No. 117 for Metals\) \(Metric\)](#)³

3. Classification

3.1 Gauge boards are furnished in two types as follows:

3.1.1 *Type I*—Gauge boards for mounting 89-mm (3½-in.) and 114-mm (4½-in.) dial size gauges as specified in [Section 5](#).

3.1.2 *Type II*—Gauge boards for mounting 152-mm (6-in.) and 216-mm (8½-in.) dial size gauges as specified in [Section 5](#).

3.2 Gauge boards are furnished in two grades as follows:

3.2.1 *Grade a*—Gauge boards are to be manufactured from carbon steel as specified in [Section 5](#).

3.2.2 *Grade b*—Gauge boards are to be manufactured from aluminum alloy as specified in [Section 5](#).

4. Ordering Information

4.1 Orders for gauge boards under this specification shall include the following information:

4.1.1 Quantity (number of gauge boards),

4.1.2 Name of item (gauge board),

4.1.3 *Type* (Type I or Type II as specified by purchaser), see [3.1.1](#) and [3.1.2](#),

4.1.4 *Grade* (Grade a or Grade b as specified by purchaser), see [3.2.1](#) and [3.2.2](#),

4.1.5 *Paint* (as specified by purchaser), see [7.2](#),

4.1.6 *Drilling for gauge mounting* (as specified by purchaser), see [5.1.1](#), and

4.1.7 ASTM designation and date of issue.

¹ This specification is under the jurisdiction of ASTM Committee F25 on Ships and Marine Technology and is the direct responsibility of Subcommittee F25.11 on Machinery and Piping Systems.

Current edition approved April 1, 2011. Published April 2011. Originally approved in 1981. Last previous edition approved in 2006 as F707/F707M – 94 (2006). DOI: 10.1520/F0707_F0707M-94R11.

² Available from American National Standards Institute (ANSI), 25 W. 43rd St., 4th Floor, New York, NY 10036, <http://www.ansi.org>.

³ Available from Standardization Documents Order Desk, DODSSP, Bldg. 4, Section D, 700 Robbins Ave., Philadelphia, PA 19111-5098, <http://dodssp.daps.dla.mil>.

5. Materials and Manufacture

5.1 Unless otherwise specified the gauge boards shall be manufactured from 11-gauge (manufacturers standard gauge) carbon steel for Grade a and 3 mm (1/8 in.) thick aluminum alloy for Grade b. Materials shall be capable of being bent at room temperature through 90° in any direction to an inside radius equal to its thickness without cracking on the outside of the bent portion.

5.1.1 Unless otherwise specified, Type I gauge boards shall be drilled for mounting both 89-mm (3 1/2-in.) and 114-mm (4 1/2-in.) dial size gauges and Type II gauge boards shall be drilled for mounting both 152-mm (6-in.) and 216-mm (8 1/2-in.) dial size gauges. When specified by the purchaser, drilling shall be limited to one size gauge for either Type I or Type II gauge boards (see 4.1.6).

6. Dimensions and Permissible Variations

6.1 The dimensions of the gauge board shall not vary by more than 0.4 mm (±1/64 in.) except as noted in Fig. 1 and Fig. 2.

7. Workmanship, Finish and Appearance

7.1 The gauge boards shall have a workmanlike finish free of scale, burrs, cracks, and other defects affecting serviceability or appearance.

7.2 If paint is not specified by the purchaser, Grade a gauge boards shall be supplied with a coat of zinc chromate primer in accordance with Federal Specification TT-P-645, Formula 84 or equal (yellow) 0.038-mm (1.5-mils) dry film thickness. Grade b gauge boards shall be supplied with one pretreatment wash coat in accordance with Specification DOD-P-15328 Formula 117 or equal (dark green) 0.013-mm (0.5-mils) dry film thickness and one coat of zinc chromate primer in accordance with Federal Specification TT-P-645 Formula 84D or equal (dark green) 0.013 mm (1.5-mils) dry film thickness.

8. Product Marking

8.1 Each shipping unit shall bear a tag or be plainly marked with the following: ASTM designation number, name or trademark of manufacturer, number of pieces, and purchase order number.

9. Keywords

9.1 dial pressure gauges; dial thermometers; modular gauge boards; pressure gauges

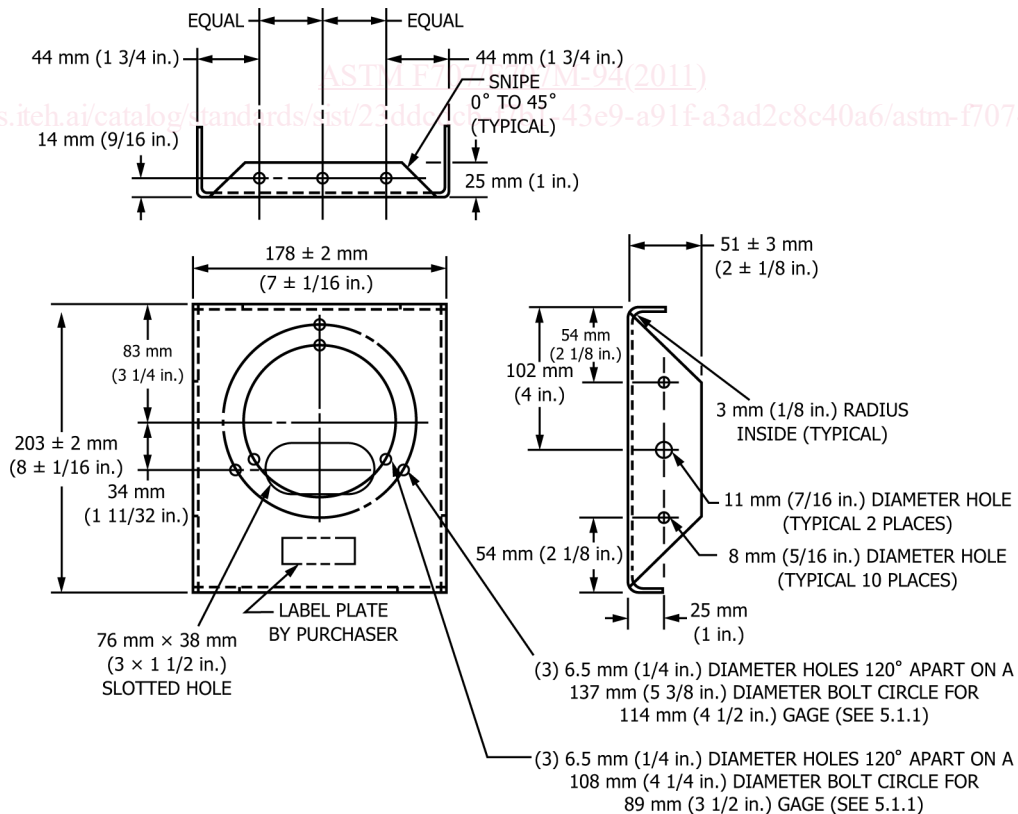

FIG. 1 Gauge Board Type I