

---

---

**Railway infrastructure — Rail  
fastening systems —**

**Part 5:  
Test method for electrical resistance**

*Infrastructure ferroviaire — Systèmes de fixation du rail —*

*Partie 5: Méthode d'essai pour la détermination de résistance  
électrique*

**iTeh STANDARD PREVIEW  
(standards.iteh.ai)**

ISO 22074-5:2021

<https://standards.iteh.ai/catalog/standards/sist/e1665078-8aae-4333-9b79-693dad17c58b/iso-22074-5-2021>



## iTeh STANDARD PREVIEW (standards.iteh.ai)

ISO 22074-5:2021

<https://standards.iteh.ai/catalog/standards/sist/e1665078-8aae-4333-9b79-693dad17c58b/iso-22074-5-2021>



### **COPYRIGHT PROTECTED DOCUMENT**

© ISO 2021

All rights reserved. Unless otherwise specified, or required in the context of its implementation, no part of this publication may be reproduced or utilized otherwise in any form or by any means, electronic or mechanical, including photocopying, or posting on the internet or an intranet, without prior written permission. Permission can be requested from either ISO at the address below or ISO's member body in the country of the requester.

ISO copyright office  
CP 401 • Ch. de Blandonnet 8  
CH-1214 Vernier, Geneva  
Phone: +41 22 749 01 11  
Email: [copyright@iso.org](mailto:copyright@iso.org)  
Website: [www.iso.org](http://www.iso.org)

Published in Switzerland

# Contents

	Page
Foreword.....	iv
Introduction.....	v
<b>1 Scope.....</b>	<b>1</b>
<b>2 Normative references.....</b>	<b>1</b>
<b>3 Terms and definitions.....</b>	<b>1</b>
<b>4 Symbols and abbreviated terms.....</b>	<b>1</b>
<b>5 Principle.....</b>	<b>1</b>
<b>6 Apparatus.....</b>	<b>2</b>
6.1 Rail.....	2
6.2 Water.....	2
6.2.1 Standard "wet" conditions.....	2
6.2.2 Optional additional test conditions.....	2
6.3 Spray equipment.....	2
6.4 Electricity supply.....	2
6.5 Instruments.....	2
6.6 Water collection and re-cycling equipment.....	2
<b>7 Test specimens (reference method).....</b>	<b>3</b>
<b>8 Procedure (reference method).....</b>	<b>3</b>
<b>9 Test specimens (alternative method).....</b>	<b>5</b>
<b>10 Procedure (alternative method).....</b>	<b>5</b>
<b>11 Calculations.....</b>	<b>5</b>
<b>12 Test report.....</b>	<b>6</b>
Bibliography.....	7

## Foreword

ISO (the International Organization for Standardization) is a worldwide federation of national standards bodies (ISO member bodies). The work of preparing International Standards is normally carried out through ISO technical committees. Each member body interested in a subject for which a technical committee has been established has the right to be represented on that committee. International organizations, governmental and non-governmental, in liaison with ISO, also take part in the work. ISO collaborates closely with the International Electrotechnical Commission (IEC) on all matters of electrotechnical standardization.

The procedures used to develop this document and those intended for its further maintenance are described in the ISO/IEC Directives, Part 1. In particular, the different approval criteria needed for the different types of ISO documents should be noted. This document was drafted in accordance with the editorial rules of the ISO/IEC Directives, Part 2 (see [www.iso.org/directives](http://www.iso.org/directives)).

Attention is drawn to the possibility that some of the elements of this document may be the subject of patent rights. ISO shall not be held responsible for identifying any or all such patent rights. Details of any patent rights identified during the development of the document will be in the Introduction and/or on the ISO list of patent declarations received (see [www.iso.org/patents](http://www.iso.org/patents)).

Any trade name used in this document is information given for the convenience of users and does not constitute an endorsement.

For an explanation of the voluntary nature of standards, the meaning of ISO specific terms and expressions related to conformity assessment, as well as information about ISO's adherence to the World Trade Organization (WTO) principles in the Technical Barriers to Trade (TBT), see [www.iso.org/iso/foreword.html](http://www.iso.org/iso/foreword.html).

This document was prepared by Technical Committee ISO/TC 269, *Railway applications*, Subcommittee SC 1, *Infrastructure*.

A list of all parts in the ISO 22074 series can be found on the ISO website.

Any feedback or questions on this document should be directed to the user's national standards body. A complete listing of these bodies can be found at [www.iso.org/members.html](http://www.iso.org/members.html).

## Introduction

This test procedure is used to assess the rail-to-rail electrical resistance relevant to rail fastenings used in locations where track circuit signalling systems are used.

## iTeh STANDARD PREVIEW (standards.iteh.ai)

[ISO 22074-5:2021](https://standards.iteh.ai/catalog/standards/sist/e1665078-8aae-4333-9b79-693dad17c58b/iso-22074-5-2021)

<https://standards.iteh.ai/catalog/standards/sist/e1665078-8aae-4333-9b79-693dad17c58b/iso-22074-5-2021>

**iTeh STANDARD PREVIEW**  
**(standards.iteh.ai)**

ISO 22074-5:2021

<https://standards.iteh.ai/catalog/standards/sist/e1665078-8aae-4333-9b79-693dad17c58b/iso-22074-5-2021>

# Railway infrastructure — Rail fastening systems —

## Part 5: Test method for electrical resistance

### 1 Scope

This document specifies a laboratory test procedure for determining the electrical resistance, in wet conditions, between the running rails provided by a fastening system fitted to a steel or concrete sleeper, bearer or element of ballastless track.

It is also applicable to embedded rail.

This test procedure applies to a complete fastening assembly. It is relevant to signalling currents, not to traction currents.

A reference procedure and an alternative procedure are included.

### 2 Normative references

The following documents are referred to in the text in such a way that some or all of their content constitutes requirements of this document. For dated references, only the edition cited applies. For undated references, the latest edition of the referenced document (including any amendments) applies.

ISO 7888, *Water quality — Determination of electrical conductivity*

ISO 22074-1, *Railway infrastructure — Rail fastening systems — Part 1: Vocabulary*

### 3 Terms and definitions

For the purposes of this document, the terms and definitions given in ISO 22074-1 apply.

ISO and IEC maintain terminological databases for use in standardization at the following addresses:

- ISO Online browsing platform: available at <https://www.iso.org/obp>
- IEC Electropedia: available at <http://www.electropedia.org/>

### 4 Symbols and abbreviated terms

- $R_{\gamma}$  measured resistance for each test, in  $\Omega$ ;
- $R$  arithmetic mean of test results, in  $\Omega$ ;
- $\gamma$  conductivity of water used, in mS/m.

### 5 Principle

The electrical resistance between two short lengths of rail fastened to the support is measured whilst the whole support and fastenings are sprayed with water at a controlled rate.

## 6 Apparatus

### 6.1 Rail

For surface mounted rail systems, two short lengths (approximately 0,5 m) of the section for which the fastening assembly under test is designed. For embedded rail systems, the rail is included in the test specimen. The rail shall be unlaminated and neither have loose rust on the surface nor be polished on the foot.

### 6.2 Water

#### 6.2.1 Standard "wet" conditions

A supply of potable water with a conductivity of  $(50 \pm 5)$  mS/m measured in accordance with ISO 7888 at the temperature at the time of spraying and corrected to a temperature of 25 °C.

NOTE 1 Correction factors for temperature are given in ISO 7888.

NOTE 2 The conductivity of the water can be adjusted to the specified limits by the addition of sodium chloride or distilled water.

#### 6.2.2 Optional additional test conditions

For some applications, additional tests in other conditions may be required, e.g. for dry conditions and/or for "polluted" wet conditions. For such tests, supply of water may be required containing sodium chloride with a conductivity specified by the authority requesting the test and measured in accordance with ISO 7888 at the temperature at the time of spraying and corrected to a temperature of 25 °C.

NOTE Correction factors for temperature are given in ISO 7888.

### 6.3 Spray equipment

A frame which can be moved parallel to the rails, incorporating four spray nozzles as shown in [Figure 1](#). The nozzles shall have a diameter of 3,6 mm and a spray cone of 100° to 125°. The equipment shall include a means of controlling and measuring the flow of water to each nozzle.

### 6.4 Electricity supply

Alternating current supply representative of the proposed operational conditions. If the supply characteristics are not specified by the authority commissioning the tests, then a supply of  $(30 \pm 3)$  V RMS and  $(50 \pm 15)$  Hz shall be used.

### 6.5 Instruments

Instruments to measure the applied voltage and resultant current flow between the rails with an accuracy of 1 % which permit the calculation of resistance over the range  $(1 \times 10^2)$  Ω to  $(1 \times 10^6)$  Ω. The equipment shall be able to print out a record of calculated resistance against time.

The calibration of the instruments shall be verified with equipment conforming to relevant local or international standards.

### 6.6 Water collection and re-cycling equipment

Water sprayed onto the sleeper and fastening assemblies may be collected and re-cycled through the test rig, provided that the conductivity and temperature are maintained within the limits set out in [6.2](#). If such a procedure is used, it is important to ensure that the entire water circulation system is designed to prevent collection of stagnant water and that the system is flushed through with clean



water regularly. Failure to do this can lead to the creation of conditions in which harmful bacteria (e.g. Legionella) collect and breed in the test rig.

NOTE Guidance on the control of Legionella in cold water systems is available in Reference [1].

## 7 Test specimens (reference method)

Three steel or concrete sleepers or bearers (with two rails only), or elements of ballastless track, with cast-in fastening components or holes and rail seats as made without modification for this test.

For elements of ballastless track, the length of the test specimen shall be equal to the typical support spacing in track.

For embedded rail, the test specimen is a typical cross-section of the track superstructure with a length in track direction equal to 0,6 m (0,8 m for light rail fastening categories), and both rail sections protruding at each end by maximum 0,1 m.

Each specimen is tested individually. The test specimens are described as sleepers in the test procedure.

## 8 Procedure (reference method)

The test shall be carried out under cover and protected from rain and draughts in a room which is ventilated and has an air temperature 15 °C to 30 °C. Fit the rails to one sleeper using all the fastening components as assembled in track. Support the sleeper, which shall be surface dry, on two blocks, not less than 50 mm thick, as shown in [Figure 1](#). These blocks shall be made from an electrically insulating material, but shall not be made from wood. Plastic pads may be placed between the blocks and the bottom of the sleeper to assist in levelling the sleeper in the test rig.

NOTE The use of wood blocks is recommended in some other standards, but it can harbour harmful bacteria in a wet environment (e.g. Legionella).

If the sleeper has not been used for this test before, carry out the spraying procedure and leave for no less than 24 h or until surface dry, whichever is longer, before performing the test.

Set up the measuring instruments as shown in [Figure 2](#) and connect to the electrical supply. Move the spray equipment over the sleeper, anchor the equipment in position and spray with water at 10 °C to 20 °C at a rate of  $(7 \pm 1)$  l/min from each nozzle for 2 min. Record the voltage and current during spraying and for not less than 10 min after spraying has ceased.

Repeat the test twice more on the other two similar test specimens. If a specimen has been previously tested, allow no less than 120 h, or the time taken for the specimen to become surface dry, whichever is the longer, between tests.

A typical resistance-time plot is shown in [Figure 3](#).

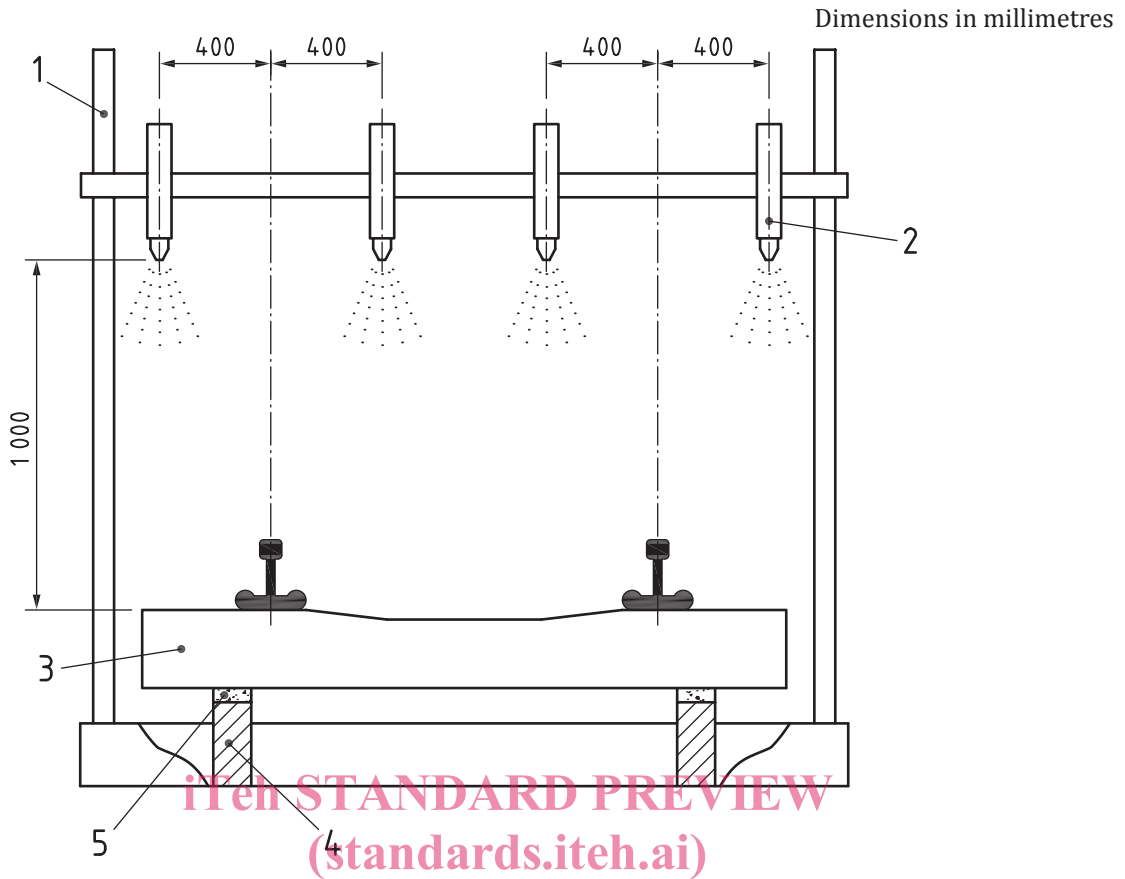

**Key**

- 1 spray frame
- 2 spray nozzles as described in 5.3
- 3 test sleepers as described in [Clause 6](#)
- 4 insulating blocks
- 5 plastic pads

ISO 22074-5:2021  
<https://standards.iteh.ai/catalog/standards/sist/e1665078-8aac-4333-9b79-693dad17c58b/iso-22074-5-2021>

**Figure 1 — Test arrangement**

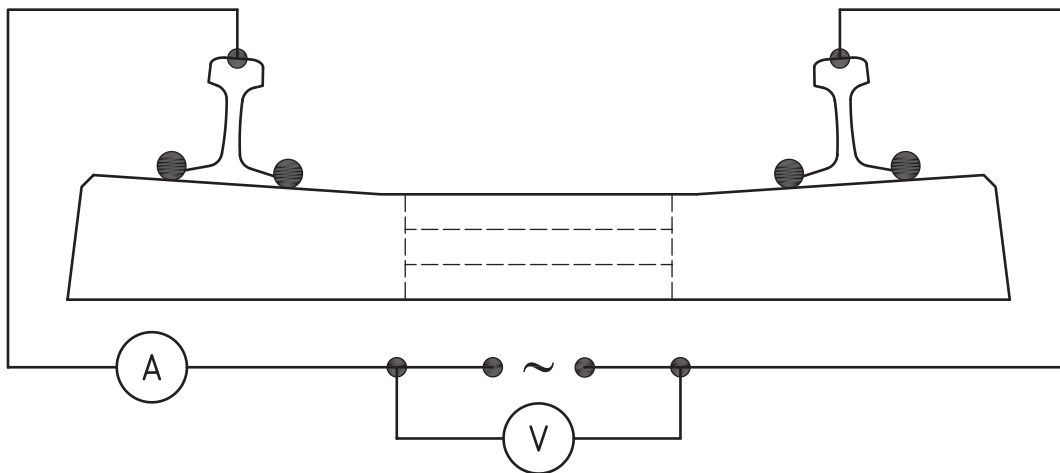

**Figure 2 — Measurement circuit**