

FINAL
DRAFT

INTERNATIONAL
STANDARD

ISO/FDIS
22074-8

ISO/TC 269/SC 1

Secretariat: AFNOR

Voting begins on:
2021-09-29

Voting terminates on:
2021-11-24

Railway infrastructure — Rail fastening systems —

Part 8: Test method for vertical stiffness

iTeh STANDARD PREVIEW
(standards.iteh.ai)

[ISO/FDIS 22074-8](https://standards.iteh.ai/catalog/standards/sist/7e661cd6-47b3-463f-b0d4-7031add358aa/iso-fdis-22074-8)

<https://standards.iteh.ai/catalog/standards/sist/7e661cd6-47b3-463f-b0d4-7031add358aa/iso-fdis-22074-8>

RECIPIENTS OF THIS DRAFT ARE INVITED TO SUBMIT, WITH THEIR COMMENTS, NOTIFICATION OF ANY RELEVANT PATENT RIGHTS OF WHICH THEY ARE AWARE AND TO PROVIDE SUPPORTING DOCUMENTATION.

IN ADDITION TO THEIR EVALUATION AS BEING ACCEPTABLE FOR INDUSTRIAL, TECHNOLOGICAL, COMMERCIAL AND USER PURPOSES, DRAFT INTERNATIONAL STANDARDS MAY ON OCCASION HAVE TO BE CONSIDERED IN THE LIGHT OF THEIR POTENTIAL TO BECOME STANDARDS TO WHICH REFERENCE MAY BE MADE IN NATIONAL REGULATIONS.



Reference number
ISO/FDIS 22074-8:2021(E)

© ISO 2021

iTeh STANDARD PREVIEW
(standards.iteh.ai)

ISO/FDIS 22074-8
<https://standards.iteh.ai/catalog/standards/sist/7e661cd6-47b3-463f-b0d4-7031add358aa/iso-fdis-22074-8>



COPYRIGHT PROTECTED DOCUMENT

© ISO 2021

All rights reserved. Unless otherwise specified, or required in the context of its implementation, no part of this publication may be reproduced or utilized otherwise in any form or by any means, electronic or mechanical, including photocopying, or posting on the internet or an intranet, without prior written permission. Permission can be requested from either ISO at the address below or ISO's member body in the country of the requester.

ISO copyright office
CP 401 • Ch. de Blandonnet 8
CH-1214 Vernier, Geneva
Phone: +41 22 749 01 11
Email: copyright@iso.org
Website: www.iso.org

Published in Switzerland

Contents

	Page
Foreword.....	iv
Introduction.....	v
1 Scope.....	1
2 Normative references.....	1
3 Terms and definitions.....	1
4 Symbols.....	1
5 Verification of calibration.....	2
6 Test procedures for pads.....	3
6.1 Static test procedure for pads.....	3
6.1.1 Principle.....	3
6.1.2 Apparatus.....	3
6.1.3 Procedure.....	4
6.1.4 Test report.....	5
6.2 Dynamic low-frequency test procedure for pads.....	6
6.2.1 General.....	6
6.2.2 Principle.....	6
6.2.3 Apparatus.....	6
6.2.4 Procedure.....	6
6.2.5 Test report.....	7
7 Test procedures for complete rail fastening assemblies.....	7
7.1 Static test procedure for fastening assemblies.....	7
7.1.1 Principle.....	7
7.1.2 Apparatus.....	7
7.1.3 Test specimens.....	8
7.1.4 Procedure.....	8
7.1.5 Test report.....	9
7.2 Dynamic low-frequency test procedure for fastening assemblies.....	9
7.2.1 General.....	9
7.2.2 Principle.....	10
7.2.3 Apparatus.....	10
7.2.4 Procedure.....	10
7.2.5 Test report.....	10
Bibliography.....	12

Foreword

ISO (the International Organization for Standardization) is a worldwide federation of national standards bodies (ISO member bodies). The work of preparing International Standards is normally carried out through ISO technical committees. Each member body interested in a subject for which a technical committee has been established has the right to be represented on that committee. International organizations, governmental and non-governmental, in liaison with ISO, also take part in the work. ISO collaborates closely with the International Electrotechnical Commission (IEC) on all matters of electrotechnical standardization.

The procedures used to develop this document and those intended for its further maintenance are described in the ISO/IEC Directives, Part 1. In particular, the different approval criteria needed for the different types of ISO documents should be noted. This document was drafted in accordance with the editorial rules of the ISO/IEC Directives, Part 2 (see www.iso.org/directives).

Attention is drawn to the possibility that some of the elements of this document may be the subject of patent rights. ISO shall not be held responsible for identifying any or all such patent rights. Details of any patent rights identified during the development of the document will be in the Introduction and/or on the ISO list of patent declarations received (see www.iso.org/patents).

Any trade name used in this document is information given for the convenience of users and does not constitute an endorsement.

For an explanation of the voluntary nature of standards, the meaning of ISO specific terms and expressions related to conformity assessment, as well as information about ISO's adherence to the World Trade Organization (WTO) principles in the Technical Barriers to Trade (TBT), see www.iso.org/iso/foreword.html.

This document was prepared by Technical Committee ISO/TC 269, *Railway applications*, Subcommittee SC 1, *Infrastructure*.

A list of all parts in the ISO 22074 series can be found on the ISO website.

Any feedback or questions on this document should be directed to the user's national standards body. A complete listing of these bodies can be found at www.iso.org/members.html.

Introduction

This document brings together test methods for measuring the stiffness of pads and fastening assemblies under static and low frequency dynamic loading.

No method for testing at frequencies above 30 Hz is included. Methods for assessing stiffness at higher frequencies can be found in other standards, including EN 15461 and EN 17495.

iTeh STANDARD PREVIEW (standards.iteh.ai)

[ISO/FDIS 22074-8](https://standards.iteh.ai/catalog/standards/sist/7e661cd6-47b3-463f-b0d4-7031add358aa/iso-fdis-22074-8)

<https://standards.iteh.ai/catalog/standards/sist/7e661cd6-47b3-463f-b0d4-7031add358aa/iso-fdis-22074-8>

iTeh STANDARD PREVIEW
(standards.iteh.ai)

ISO/FDIS 22074-8

<https://standards.iteh.ai/catalog/standards/sist/7e661cd6-47b3-463f-b0d4-7031add358aa/iso-fdis-22074-8>

Railway infrastructure — Rail fastening systems —

Part 8: Test method for vertical stiffness

1 Scope

This document specifies laboratory test procedures to determine the static and low frequency dynamic stiffness of rail pads, baseplate pads and complete rail fastening assemblies.

2 Normative references

The following documents are referred to in the text in such a way that some or all of their content constitutes requirements of this document. For dated references, only the edition cited applies. For undated references, the latest edition of the referenced document (including any amendments) applies.

ISO 7500-1:2018, *Metallic materials — Calibration and verification of static uniaxial testing machines — Part 1: Tension/compression testing machines — Calibration and verification of the force-measuring system*

ISO 9513:2012, *Metallic materials — Calibration of extensometer systems used in uniaxial testing*

ISO 22074-1, *Railway infrastructure — Rail fastening systems — Part 1: Vocabulary*

3 Terms and definitions

For the purposes of this document, the terms and definitions given in ISO 22074-1 and the following apply.

ISO and IEC maintain terminological databases for use in standardization at the following addresses:

- ISO Online browsing platform: available at <https://www.iso.org/obp>
- IEC Electropedia: available at <http://www.electropedia.org/>

3.1

static stiffness

force required to cause a unit displacement of a pad or a rail fastening assembly with the load applied slowly enough to avoid all significant loading rate effects

3.2

low frequency dynamic stiffness

force required to cause a unit displacement of a pad or a rail fastening assembly with a cyclic load applied at a frequency and force amplitude representative of the loading in railway track associated with passing wheels or bogies

4 Symbols

Symbol	Description	Relevant subclause
F_{SPmax}	reference force applied to pad in measurement of static stiffness of pad, in kN;	6.1.3
F_{SP1}	lower limit of force for determining the static secant stiffness of a pad, in kN (approximately equal to the clamping force expected in a fastening system);	6.1.3
F_{SP2}	upper limit of force for determining the static secant stiffness of a pad, in kN	6.1.3
k_{SP}	static stiffness of pad, in MN/m;	6.1.3
d_{SP1}	vertical displacement of pad with force F_{SP1} applied, in mm;	6.1.3
d_{SP2}	vertical displacement of pad with force F_{SP2} applied, in mm;	6.1.3
F_{LFPmax}	reference force for measurement of dynamic low frequency stiffness of pad, in kN;	6.2.3.2
F_{LFP1}	lower limit of force for determining the dynamic low frequency stiffness of pad, in kN (approximately equal to the clamping force expected in a fastening system);	6.2.4
F_{LFP2}	upper limit of force for determining the dynamic low frequency stiffness of pad, in kN	6.2.4
d_{LFP1}	vertical displacement of pad with force F_{LFP1} applied in mm;	6.2.4
d_{LFP2}	vertical displacement of pad with force F_{LFP2} applied in mm;	6.2.4
f_{LFP}	frequency of measurement of low frequency measurement dynamic stiffness of pad, in Hz;	6.2.4
k_{LFPf}	low frequency dynamic stiffness of pad at a specific frequency, in MN/m;	6.2.4
$k_{LFPmean}$	mean of measurements of low frequency dynamic stiffness of pad measured at 5 Hz, 10 Hz and 20 Hz, in MN/m;	6.2.4
F_{SAmax}	reference force for measurement of static stiffness of assembly, in kN;	7.1.4
k_{SA}	static stiffness of assembly, in MN/m;	7.1.4
d_{SA1}	vertical displacement of rail with force F_{SA1} applied, in mm;	7.1.4
d_{SA2}	vertical displacement of rail with force F_{SA2} applied, in mm;	7.1.4
F_{SA1}	lower limit of force for determining the static secant stiffness of assembly, in kN;	7.1.4
F_{SA2}	upper limit of force for determining the static secant stiffness of assembly = 0,8 F_{SAmax} , in kN;	7.1.4
k_{LFA}	low frequency dynamic stiffness of assembly, in MN/m;	7.2.4
F_{LFA1}	lower limit of force for determining the dynamic low frequency stiffness of assembly, in kN;	7.2.4
F_{LFA2}	upper limit of force for determining the dynamic low frequency stiffness of assembly, in kN;	7.2.4
F_{LFAmax}	reference force for measurement of dynamic low frequency stiffness of assembly, in kN;	7.2.4
d_{LFA1}	vertical displacement of rail in measurement of dynamic low frequency stiffness of assembly for force F_{LFA1} , in mm;	7.2.4
d_{LFA2}	vertical displacement of rail in measurement of dynamic low frequency stiffness of assembly for force F_{LFA2} , in mm.	7.2.4

5 Verification of calibration

The static calibration of actuators shall be verified in accordance with ISO 7500-1 using equipment having traceability to European or International Standards using the International System of Units (SI).

The calibration of displacement-measuring instruments shall be in accordance with ISO 9513.

6 Test procedures for pads

6.1 Static test procedure for pads

6.1.1 Principle

A force is applied normal to the test pad and the displacement is measured.

6.1.2 Apparatus

6.1.2.1 Controlled temperature test area, area of the laboratory where the test is conducted, maintained at $(25 \pm 5) ^\circ\text{C}$.

Where pads are to be used at other ambient temperatures, additional tests shall be performed in a temperature-controlled chamber, if required by the purchaser, at one or more of the following temperatures: $(-30 \pm 3) ^\circ\text{C}$, $(-20 \pm 3) ^\circ\text{C}$, $(-10 \pm 3) ^\circ\text{C}$, $(0 \pm 3) ^\circ\text{C}$ and $(50 \pm 3) ^\circ\text{C}$.

Additional test temperatures may be agreed between the manufacturer and the purchaser.

6.1.2.2 Metal plate, rigid, larger than the load distribution plate.

6.1.2.3 Load distribution plate, rectangular upper load distribution, made from metal 10 mm minimum thickness, with smooth, rounded edges, such that the load distribution plate does not damage the pad under test. The dimensions of the plate depend on the type of pad being tested as follows:

- Rail pads: the same width as the foot of the rail used for the repeated loading test (see ISO 22074-4) and a length of 210 mm. Alternatively, a short length of rail, at least 210 mm long, may be used instead of the upper load distribution plate and upper metal plate.
- Baseplate pads: the same width and length as the maximum rectangular area within the part of the baseplate transmitting the load to the pad in the fastening assembly.

When the pad is supported in use over a limited area, a lower load distribution plate, of the same dimensions as the part of the pad which would be actively supported in the fastening assembly, is also required.

NOTE 1 For tests on continuous pads used in slab track a length of pad of 150 mm is used.

NOTE 2 If the metal plate described in 6.1.2.2 matches the size of the upper load distribution plate, the load distribution plate can be omitted.

6.1.2.4 Abrasive cloth, with grit size P120 to P400 (ISO 6344) in unworn condition, the dimensions of each sheet being not less than the full area of the pad to be tested.

6.1.2.5 Actuator capable of applying a force of $(F_{\text{SPmax}} + 10 \%)$ kN through a spherical seating.

NOTE Typically, the maximum force is 120 kN.

6.1.2.6 Displacement-measuring instruments

- a) If contacting displacement-measuring instruments are used, they shall conform with ISO 9513.
- b) If non-contacting displacement-measuring instruments are used, they shall be calibrated to ensure that they can measure the displacement of the metal plate relative to the base as required in 6.1.3.

The instruments shall be capable of measuring displacements as follows:

- for pads with a declared stiffness ≤ 100 MN/m, displacement measurement within $\pm 0,02$ mm;

— for pads with a declared stiffness > 100 MN/m, displacement measurement within $\pm 0,01$ mm.

6.1.2.7 Force measuring instruments conforming with ISO 7500-1:2018, Class 1 over the required range of force.

6.1.2.8 Recording equipment, to make a digital recording and print out of the displacement and applied force.

6.1.3 Procedure

All components and equipment used shall be kept at a temperature of (25 ± 5) °C or another test temperature (see 6.1.2.1) for at least 16 h prior to starting the test. Place the test set-up on a flat, rigid, horizontal base, which supports the whole area of the pad, in the following sequence: base, lower load distribution plate (if necessary), abrasive cloth (abrasive side up), pad, abrasive cloth (abrasive side down), upper load distribution plate, metal plate as shown in Figure 1.

Ensure the load distribution plates are located on the active area of the pad. Locate at least three independent instruments to measure the displacement of the metal plate at equal intervals around the perimeter of the plate.

Apply a force, F_{SPmax} , with a rate of application (120 ± 10) kN/min as specified in the performance requirements for the type of track for which the pad is intended.

NOTE Performance requirements are set out in other standards.

Reduce the force to the minimum value (F_{SP1}) and repeat this cycle of loading and unloading twice more. Increase the applied force from F_{SP1} to F_{SPmax} recording the displacement while increasing the force in this final cycle.

If the displacement measured by any of the instruments differs from the average displacement by ≥ 20 % of the maximum displacement, repeat the loading cycle, ensuring that the force is applied centrally to the pad. Calculate the static stiffness in MN/m from Formula (1) where d_{SP1} and d_{SP2} are the displacements associated with the applied forces F_{SP1} and F_{SP2} .

$$k_{SP} = \frac{F_{SP2} - F_{SP1}}{d_{SP}} \quad (1)$$

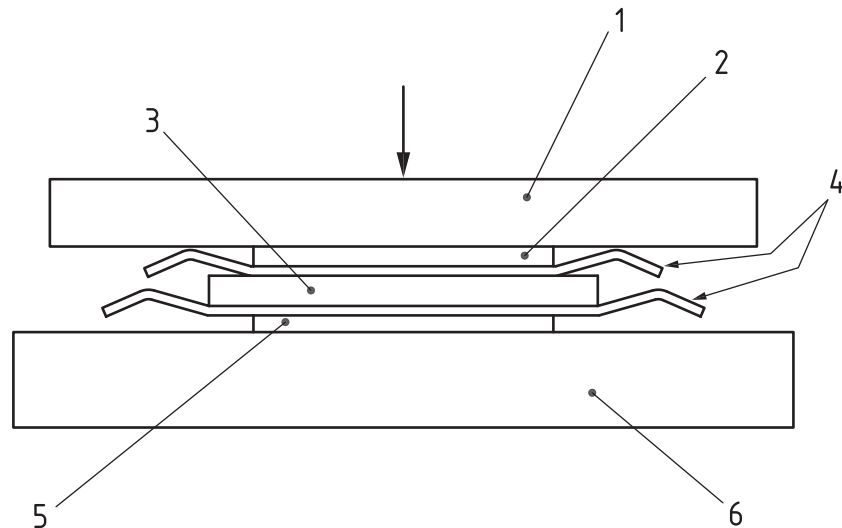
**Key**

- 1 metal plate with vertical load applied as indicated by downward arrow
- 2 upper load distribution plate (if necessary)
- 3 pad to be tested
- 4 abrasive cloth
- 5 lower load distribution plate (if necessary)
- 6 base

iTeh STANDARD PREVIEW
 (standards.iteh.ai)

Figure 1 — Test arrangement for pads

[ISO/FDIS 22074-8](https://standards.iteh.ai/catalog/standards/sist/7e661cd6-47b3-463f-b0d4-7031add358aa/iso-fdis-22074-8)

6.1.4 Test report

<https://standards.iteh.ai/catalog/standards/sist/7e661cd6-47b3-463f-b0d4-7031add358aa/iso-fdis-22074-8>

The test report shall include at least the following information:

- a) a reference to this document (i.e. ISO 22074-8:—);
- b) name and address of the laboratory performing the test;
- c) date test performed;
- d) name, designation and description of the pads tested;
- e) origin of the test specimens;
- f) intended use of the pad tested;
- g) configuration of the load distribution plates used in the test;
- h) temperature at which the test was performed;
- i) values of F_{SP1} and F_{SP2} ;
- j) a representative load-deflection curve;
- k) static stiffness of the pads tested.