

---

---

**Plain bearings — Pedestal plain  
bearings —**

**Part 3:  
Centre flange bearings**

*Paliers lisses — Paliers lisses à chaise sur le sol —*

*Partie 3: Paliers à bride centrale*  
**iTeh STANDARD PREVIEW  
(standards.iteh.ai)**

ISO 11687-3:2020

<https://standards.iteh.ai/catalog/standards/sist/25b2b5b7-aca8-44ed-87d9-622ca379c303/iso-11687-3-2020>



**iTeh STANDARD PREVIEW**  
**(standards.iteh.ai)**

ISO 11687-3:2020

<https://standards.iteh.ai/catalog/standards/sist/25b2b5b7-aca8-44ed-87d9-622ca379c303/iso-11687-3-2020>



**COPYRIGHT PROTECTED DOCUMENT**

© ISO 2020

All rights reserved. Unless otherwise specified, or required in the context of its implementation, no part of this publication may be reproduced or utilized otherwise in any form or by any means, electronic or mechanical, including photocopying, or posting on the internet or an intranet, without prior written permission. Permission can be requested from either ISO at the address below or ISO's member body in the country of the requester.

ISO copyright office  
CP 401 • Ch. de Blandonnet 8  
CH-1214 Vernier, Geneva  
Phone: +41 22 749 01 11  
Fax: +41 22 749 09 47  
Email: [copyright@iso.org](mailto:copyright@iso.org)  
Website: [www.iso.org](http://www.iso.org)

Published in Switzerland

# Contents

	Page
Foreword .....	iv
<b>1 Scope .....</b>	<b>1</b>
<b>2 Normative references .....</b>	<b>1</b>
<b>3 Terms and definitions .....</b>	<b>1</b>
<b>4 Types of bearing .....</b>	<b>2</b>
4.1 General .....	2
4.2 Housing .....	2
4.3 Heat dissipation .....	2
4.4 Shape of bore for journal bearing and type of lubrication .....	2
4.5 Thrust bearing .....	2
4.6 Seal .....	2
<b>5 Dimensions .....</b>	<b>3</b>
<b>6 Shaft design .....</b>	<b>3</b>
<b>7 Materials .....</b>	<b>3</b>
<b>8 Design .....</b>	<b>3</b>
8.1 General tolerances .....	3
8.2 Surface roughness .....	3
8.3 Housing .....	4
8.4 General .....	4
<b>9 Designation .....</b>	<b>4</b>

[ISO 11687-3:2020](https://standards.iteh.ai/catalog/standards/sist/25b2b5b7-aca8-44ed-87d9-622ca379c303/iso-11687-3-2020)  
<https://standards.iteh.ai/catalog/standards/sist/25b2b5b7-aca8-44ed-87d9-622ca379c303/iso-11687-3-2020>

## Foreword

ISO (the International Organization for Standardization) is a worldwide federation of national standards bodies (ISO member bodies). The work of preparing International Standards is normally carried out through ISO technical committees. Each member body interested in a subject for which a technical committee has been established has the right to be represented on that committee. International organizations, governmental and non-governmental, in liaison with ISO, also take part in the work. ISO collaborates closely with the International Electrotechnical Commission (IEC) on all matters of electrotechnical standardization.

The procedures used to develop this document and those intended for its further maintenance are described in the ISO/IEC Directives, Part 1. In particular, the different approval criteria needed for the different types of ISO documents should be noted. This document was drafted in accordance with the editorial rules of the ISO/IEC Directives, Part 2 (see [www.iso.org/directives](http://www.iso.org/directives)).

Attention is drawn to the possibility that some of the elements of this document may be the subject of patent rights. ISO shall not be held responsible for identifying any or all such patent rights. Details of any patent rights identified during the development of the document will be in the Introduction and/or on the ISO list of patent declarations received (see [www.iso.org/patents](http://www.iso.org/patents)).

Any trade name used in this document is information given for the convenience of users and does not constitute an endorsement.

For an explanation of the voluntary nature of standards, the meaning of ISO specific terms and expressions related to conformity assessment, as well as information about ISO's adherence to the World Trade Organization (WTO) principles in the Technical Barriers to Trade (TBT) see [www.iso.org/iso/foreword.html](http://www.iso.org/iso/foreword.html).

This document was prepared by Technical Committee ISO/TC 123, *Plain bearings*, Subcommittee SC 3, *Dimensions, tolerances and construction details*. ISO 11687-3:2020

<https://standards.iteh.ai/catalog/standards/sist/25b2b5b7-aca8-44ed-87d9->

This second edition cancels and replaces the first edition (ISO 11687-3:1995), which has been technically revised.

The main changes compared to the previous edition are as follows:

- in [Clause 2](#), the normative references have been updated;
- the former [Clause 6](#) is now [Clause 7](#).

A list of all parts in the ISO 11687 series can be found on the ISO website.

Any feedback or questions on this document should be directed to the user's national standards body. A complete listing of these bodies can be found at [www.iso.org/members.html](http://www.iso.org/members.html).

# Plain bearings — Pedestal plain bearings —

## Part 3: Centre flange bearings

### 1 Scope

This document specifies design characteristics for centre flange bearings for the size range 9 to 28, as well as design characteristics for shafts.

It is applicable to centre flange bearings used mainly in electrical and turbo engineering industries.

### 2 Normative references

The following documents are referred to in the text in such a way that some or all of their content constitutes requirements of this document. For dated references, only the edition cited applies. For undated references, the latest edition of the referenced document (including any amendments) applies.

ISO 185, *Grey cast irons — Classification*

ISO 630-2, *Structural steels — Part 2: Technical delivery conditions for structural steels for general purposes*

ISO 683-3, *Heat-treatable steels, alloy steels and free-cutting steels — Part 3: Case-hardening steels*

ISO 1302, *Geometrical Product Specifications (GPS) — Indication of surface texture in technical product documentation*

ISO 2768-1, *General tolerances — Part 1: Tolerances for linear and angular dimensions without individual tolerance indications*

ISO 2768-2, *General tolerances — Part 2: Geometrical tolerances for features without individual tolerance indications*

ISO 4381, *Plain bearings — Tin casting alloys for multilayer plain bearings*

ISO 8062-3, *Geometrical product specifications (GPS) — Dimensional and geometrical tolerances for moulded parts — Part 3: General dimensional and geometrical tolerances and machining allowances for castings*

ISO 12129-1, *Plain bearings — Tolerances — Part 1: Fits*

ISO 12129-2, *Plain bearings — Tolerances — Part 2: Tolerances on form and position and surface roughness for shafts and thrust collars*

ISO 14737, *Carbon and low alloy cast steels for general applications*

ASTM B124/B124M, *Standard Specification for Copper and Copper Alloy Forging Rod, Bar, and Shapes*

### 3 Terms and definitions

No terms and definitions are listed in this document.

ISO and IEC maintain terminological databases for use in standardization at the following addresses:

- ISO Online browsing platform: available at <https://www.iso.org/obp>
- IEC Electropedia: available at <http://www.electropedia.org/>

## 4 Types of bearing

### 4.1 General

According to their design, centre flange bearings can be classified as per 4.2 to 4.5, each characteristic being designated by a letter symbol.

Figure 1 shows an example of centre flange bearing. It represents centre flange bearings, which are ready to be installed, in the size ranges 9 to 28.

The symbols above Figure 1 explain only the type illustrated; the complete type required shall be specified in the below-mentioned sequence when ordering.

### 4.2 Housing

M Centre flange bearing with cooling fins

### 4.3 Heat dissipation

N Natural cooling

W Water cooling in oil sump

U Circulation pump and natural cooling ISO 11687-3:2020  
<https://standards.iteh.ai/catalog/standards/sist/25b2b5b7-aca8-44ed-87d9-622aa379c303/iso-11687-3-2020>

T Circulation pump and water cooling in oil sump

Z Recirculating oil lubrication with external cooling of oil

### 4.4 Shape of bore for journal bearing and type of lubrication

C Circular cylindrical bore without oil ring

L Circular cylindrical bore with split oil ring not fixed on a rotating shaft

Y Lobed bearing with two sliding surfaces without oil ring

V Lobed bearing with four sliding surfaces without oil ring

### 4.5 Thrust bearing

Q Without sliding surfaces [non-locating (free) bearing]

B Plain sliding surfaces with oil grooves (guide bearing)

K Wedge surfaces

A Tilting pads

} (design and dimensions at the manufacturer's discretion)

### 4.6 Seal

The type and dimensions shall be subjected to agreement.

## 5 Dimensions

The dimensions of [Table 1](#) (see [Figure 1](#)) shall apply.

The centre flange bearings are not expected to conform to the design illustrated in [Figure 1](#); conformance is only required with respect to the dimensions specified.

NOTE Unless otherwise specified, all dimensions are given in millimetres.

Details which are not specified shall be chosen as appropriate.

## 6 Shaft design

The dimensions of [Table 2](#) (see [Figures 2](#) and [3](#)) shall apply.

## 7 Materials

The materials shall meet the following criteria:

- The housing shall be of grade 300 in accordance with ISO 185; other materials may be used subject to agreement.
- Half-bearing: the bearing back shall be:

**iTeh STANDARD PREVIEW**

S235 B in accordance with ISO 630-2,

C10R or C15R in accordance with ISO 683-3, or

GE 200 or GS 200 in accordance with ISO 14737

<https://standards.iteh.ai/catalog/standards/ist/25b2b5b7-aca8-44ed-87d9-622ca379c303/iso-11687-3-2020>

Type of material at the manufacturer's discretion

- The bearing metal shall be tin-casting-alloy in accordance with ISO 4381, or subject to agreement.
- The seal shall be made of copper alloy, aluminium alloy or plastic, subject to agreement.
- The oil ring, not fixed on rotating shaft, shall be made of copper-zinc alloy in accordance with ASTM B124/B124M, or subject to agreement.

## 8 Design

### 8.1 General tolerances

- For machined surfaces, general tolerances shall be in accordance with ISO 2768-1 and ISO 2768-2 — mH.
- For unmachined surfaces, general tolerances shall be in accordance with ISO 8062-3 — DCTG 9 (for grade 300), or corresponding standards for other materials agreed upon.

### 8.2 Surface roughness

Surface roughness shall be in accordance with ISO 1302.

The flange bearing shall meet the following criteria:

- Mounted surfaces: Ra = 3,2 µm

- Sliding surfaces:  $R_a = 0,8 \mu\text{m}$

For the shaft, see [Table 2](#), footnote a.

### 8.3 Housing

The following applies to the housing.

- The centre flange bearing housing shall be equipped with lifting eye bolts or means of conveyance at the manufacturer's discretion.
- The inner surfaces of the housing shall be clean and shall have a coat of paint resistant to oil and solvents.
- The outer surfaces of the housing shall be protected against corrosion.
- For the purpose of pressure compensation, the individual oil spaces within the flange bearing housing shall be connected to each other by means of appropriate openings above the oil level.
- All bearing housing connections shall be provided on both sides; other connecting dimensions and arrangements than those given in [Figure 1](#) as well as additional connections shall be subject to agreement.
- The type of inspection plate shall be at the manufacturer's discretion.
- Bolts and screws for housing parts and seals shall be provided, at the manufacturer's discretion.
- Bolts and screws for the housing flange do not form part of the delivery.

### 8.4 General

- Particular agreements shall be made for applications under special conditions (e.g. inclined positions).
- For chamfered edges, the type of edge chamfering shall be at the manufacturer's discretion.
- If the bearing is only applicable to one direction of rotation, a directional arrow shall be provided.

## 9 Designation

EXAMPLE Designation of a centre flange bearing of size 14, shaft diameter 125 mm, housing with cooling fins (M), for recirculating oil lubrication with external cooling of oil (Z), circular cylindrical bore with split oil ring not fixed on a rotating shaft for emergency run (L) and thrust bearing with wedge surfaces (K):



Centre flange bearing ISO 11687-3 — 14 — 125 — MZLK

M.LB  
M.LK

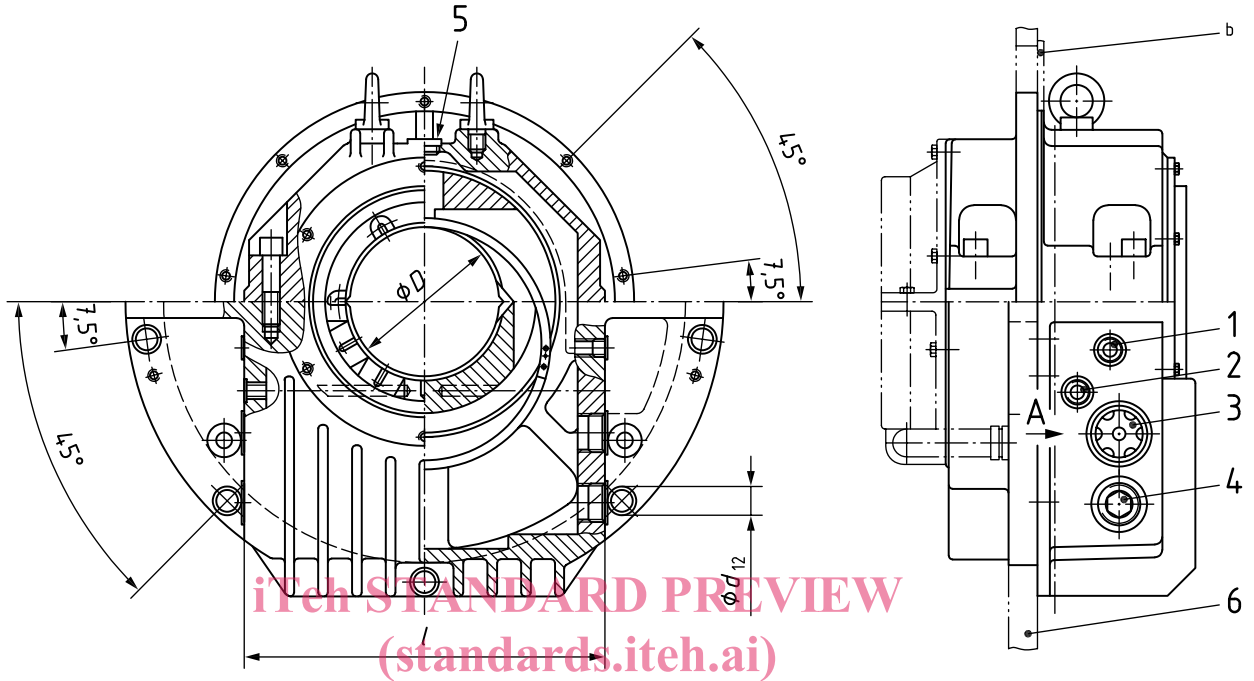

ISO 11687-3:2020  
<http://standards.iteh.ai/catalog/standards/sist/25b2b5b7-aca8-44ed-87d9-627773034111/iso-11687-3-2020>

