



Standard Specification for Protective Headgear with Faceguard Used in Bull Riding¹

This standard is issued under the fixed designation F2530; the number immediately following the designation indicates the year of original adoption or, in the case of revision, the year of last revision. A number in parentheses indicates the year of last reapproval. A superscript epsilon (ϵ) indicates an editorial change since the last revision or reapproval.

INTRODUCTION

Bull riding is a sport with intrinsic hazards. It is recognized that it is not possible to write a protective headgear with faceguard standard specification that will result in headgear with faceguards that can protect against injury or death in all accidents. Because of complex interactions of variables such as bull motion, bull size and weight, rider size, direction and point of impact, and individual differences in reaction to impact forces, it must be kept in mind that injuries are still possible. It is also recognized that serious injury or death can result from both low-energy and high-energy impacts, even when protective headgear with faceguard is worn. It is further recognized that protective headgear with faceguards must be acceptable to the user and to the regulating associations or agencies requiring its use.

In bull riding, where the force of impact between the bull and the face of the rider can cause head and facial injury, there is a need for both head and facial protection. After careful consideration of the mechanisms and forces involved in this context, this standard specification for headgear with faceguards has been prepared, using resources in medical, scientific, mechanical engineering, human factors, and biomechanical fields.

This specification is a series of laboratory tests of the protective headgear with faceguard. The headgear testing measures its ability to reduce head acceleration when impacting various shaped objects. The faceguard testing checks its ability to limit contact with the user face to reduce the potential for facial injuries.

This specification incorporates many aspects of other recognized headgear standard specifications.

Other intentions that were not amenable to testing or inspection are offered as guidelines:

- (1) The chin strap should be attached in a manner to enable the headgear with faceguard to remain in its normal position on the wearer's head during bull riding and impact conditions;
- (2) The physical characteristics of materials used in construction of the headgear with faceguard should retain their shock-absorbing characteristics under the influence of aging, use, or exposure to typical environmental conditions;
- (3) The faceguard should not significantly interfere with the vision of the wearer; and
- (4) In the event of injury, the headgear with faceguard should be removable without causing movement to the cervical spine. The access provided shall be sufficient for the administration of cardiopulmonary resuscitation to the wearer.

1. Scope

1.1 This specification covers performance requirements and describes test methods for protective headgear with faceguards for use in bull riding.

1.2 All testing and requirements of this specification shall be in accordance with Test Methods F1446, except where noted herein.

1.3 Partial utilization of this specification is prohibited. Any statement of compliance with this specification shall be a certification that the headgear with faceguard meets all of the requirements of the specification in their entirety. A headgear with faceguard that fails to meet any one of the requirements of this specification is considered to have failed the specification, and shall not be sold with any indication that it meets parts of the specification.

¹ This specification is under the jurisdiction of ASTM Committee F08 on Sports Equipment and Facilities and is the direct responsibility of Subcommittee F08.53 on Headgear and Helmets.

Current edition approved Nov. 15, 2005. Published December 2005. DOI: 10.1520/F2530-05.

Current edition approved April 1, 2011. Published May 2011. Originally approved in 2005. Last previous edition approved in 2005 as F2530 - 05. DOI: 10.1520/F2530-11.

1.4 Headgear with faceguards designed to comply with this and other standards may proclaim uses as certified by the manufacturer.

1.5 The values stated in SI units are to be regarded as standard.

1.6 *This standard does not purport to address all of the safety concerns, if any, associated with its use. It is the responsibility of the user of this standard to establish appropriate safety and health practices and determine the applicability of regulatory limitations prior to use.*

2. Referenced Documents

2.1 ~~ASTM Standards:~~

~~F910 Specification for Face Guards for Youth Baseball~~ ASTM Standards:²

F1163 Specification for Protective Headgear Used in Horse Sports and Horseback Riding

F1446 Test Methods for Equipment and Procedures Used in Evaluating the Performance Characteristics of Protective Headgear

F2220 Specification for Headforms

2.2 ~~NOCSAE Document:~~ CSA Document:³

~~NOCSAE DOC.001 Standard Drop Test Method and Equipment used in Evaluating the Performance Characteristics of Protective Headgear~~ CSA Z262.6 Specification for facially featured headforms

3. Terminology

3.1 Definitions as identified in Test Methods F1446.

3.2 *Definition of Term Specific to This Standard:*

3.2.1 *simulated horn*—a rigid metal rod that is a conservative representation of a bull’s horn.

4. Significance and Use

4.1 The purpose of this specification is to provide reliable and repeatable test methods for the evaluation of headgear with faceguards for bull riding. Headgear with faceguards satisfying this specification are intended to reduce forces reaching the head in some of the impacts that may occur in bull riding and to limit contact with the facial features of the rider.

5. Certification

5.1 This specification permits self-certification. It is recommended that each manufacturer employ an independent test laboratory at least annually to test each model and size of headgear with faceguard offered for sale.

6. Apparatus

6.1 Apparatus used for this testing shall be in accordance with Test Methods F1446 except as noted below.

6.2 *Reference or Full-facial Headform* to be used shall be as specified in:

6.2.1 The section on Other (Reference) Headforms of Specification F2220.

~~6.2.2 Standard drop test method and equipment used in evaluating the performance characteristics of protective headgear of NOCSAE DOC.001~~

6.2.2 Full-facial headforms of CSA Z262.6.⁴

6.3 *Simulated Horn*—A rigid steel rod representative of a bull’s horn, Fig. 1. The end of the rod is 30.4 mm (1.20 in.) in diameter, flat, and perpendicular to the axis of the rod with a 2 mm (0.08 in.) radius round. There is a 5° taper along the length of the rod with the diameter increasing. The overall length of the rod shall be at least 15 cm (6.0 in.) long. The hardness of the rod shall be Brinell Hardness 200 or greater.

6.4 *Simulated Horn Striker*—A 5 kg (11 lb) striker as identified in the chin bar rigidity test of Test Methods F1446 that has been modified by attaching the simulated horn to the impact face of the striker. The longitudinal axis of the simulated horn shall be perpendicular to the face of the striker.

TEST METHODS

7. Number of Samples

7.1 A minimum of four headgear with faceguards are required for testing for each shell/liner combination. Damage to the faceguard and its attachment to the headgear may occur during testing. This damage is not considered a failure unless the performance criteria are not met.

² For referenced ASTM standards, visit the ASTM website, www.astm.org, or contact ASTM Customer Service at service@astm.org. For *Annual Book of ASTM Standards* volume information, refer to the standard’s Document Summary page on the ASTM website.

³ Available from NOCSAE, P.O. Box 12290, Overland, KS 66282-2290, or www.nocsae.org.

³ Available from Canadian Standards Association (CSA), 5060 Spectrum Way, Mississauga, ON L4W 5N6, Canada, <http://www.csa.ca>.

⁴ The sole source of supply of the NOCSAE headforms known to the committee at this time is Southern Impact Research Center, 304 Dunavant Drive, Rockford, TN 37853, Canadian Standards Association (CSA), 5060 Spectrum Way, Mississauga, ON L4W 5N6, Canada, <http://www.csa.ca>. If you are aware of alternative suppliers, please provide this information to ASTM International Headquarters. Your comments will receive careful consideration at a meeting of the responsible technical committee, which you may attend.

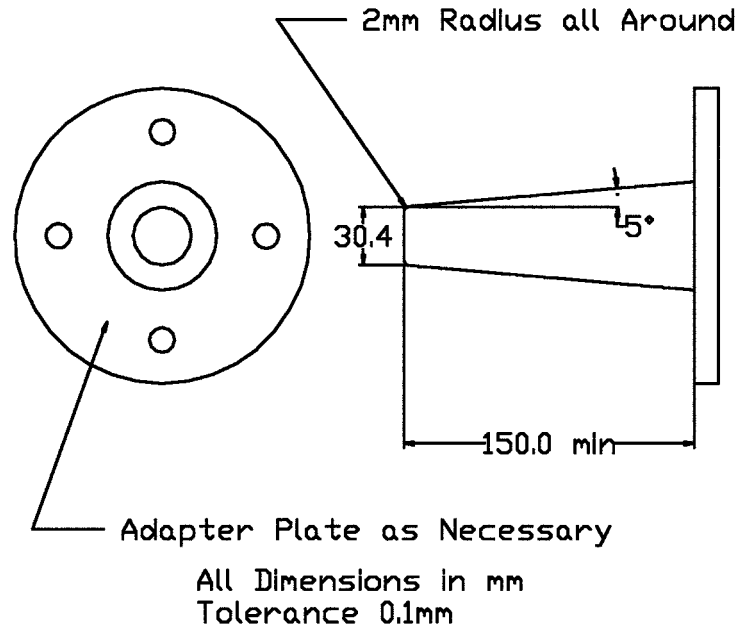

FIG. 1 Simulated Horn

7.2 Headgear with faceguard shall be tested complete, in the condition as offered for sale. The headgear with faceguard must satisfy all requirements of this specification with or without any included attachments.

8. Selection of Headform

8.1 The appropriate size headform shall be selected based on the headform size selection terminology of Test Methods F1446 for the headgear with faceguard to be tested.

9. Reference Marking

9.1 Marking the test line shall be in accordance with the Reference Marking requirements of Test Methods F1446.

9.2 Mark the test line on the headgear as shown in Fig. 2.

9.3 Mark the no contact area on the reference or full-facial headform as identified in Fig. 3. The no contact area is based on that identified in Specification F910. Indicator paste shall be applied to the no contact area of the headform used. The thickness of the indicator paste shall be no greater than 2.5 mm (0.1 in.).

10. Headgear with Faceguard Inspection

10.1 The configuration requirements of the section on Configuration of Test Methods F1446 shall be satisfied.

10.1.1 Ventilation ports are allowed, as long as all other requirements of this specification are satisfied.

10.1.2 Physical intrusion testing is based on use of the simulated horn. Physical intrusion testing shall be performed at any point on the headgear with faceguard. Mount and adjust the headgear with faceguard on the appropriately sized reference or full-facial headform in accordance with the instructions provided by the manufacturer. An attempt shall be made to enter the simulated horn, in all possible orientations, into all openings of the headgear with faceguard. The simulated horn shall be placed on the surface of the headgear with faceguard and a static force of 5 kg (11 lb) applied along the length of the simulated horn. The end of the simulated horn shall not intrude such that it contacts the no contact area nor the headform above the test line on the reference or full-facial headform.

10.2 The materials requirements of the section on Materials of Test Methods F1446 shall be satisfied.

10.3 *Labeling Requirements:*

10.3.1 Headgear shall contain labels that satisfy the labeling requirements of Test Methods F1446.

10.3.2 In addition, one of the interior labels of the headgear shall have the words "For the use in the Sport of Bull Riding."

10.3.3 Warning that the headgear with faceguard should not be worn before the user has carefully read the included fitting and care instructions.

10.3.4 Warning that the headgear with faceguard should be fitted prior to use.

10.3.5 Any other warnings, cautions, or instructions desired by the manufacturer should be included with the headgear.

10.4 The projections requirements in Test Methods F1446 shall be satisfied.

10.5 The peripheral vision requirements in Test Methods F1446 shall be satisfied. The headgear shall provide peripheral vision clearance of at least 105° to each side of the midsagittal plane when the headgear on the reference headform in accordance with