



Designation: E2472 – 06^{ε1}

Standard Test Method for Determination of Resistance to Stable Crack Extension under Low-Constraint Conditions¹

This standard is issued under the fixed designation E2472; the number immediately following the designation indicates the year of original adoption or, in the case of revision, the year of last revision. A number in parentheses indicates the year of last reappraisal. A superscript epsilon (ϵ) indicates an editorial change since the last revision or reappraisal.

^{ε1} NOTE—3.2.16 was editorially revised in May 2010.

1. Scope

1.1 This standard covers the determination of the resistance to stable crack extension in metallic materials in terms of the critical crack-tip-opening angle (CTOA_c), ψ_c and/or the crack-opening displacement (COD), δ_5 resistance curve (**1**).² This method applies specifically to fatigue pre-cracked specimens that exhibit low constraint (crack-length-to-thickness and uncracked ligament-to-thickness ratios greater than or equal to 4) and that are tested under slowly increasing remote applied displacement. The recommended specimens are the compact-tension, C(T), and middle-crack-tension, M(T), specimens. The fracture resistance determined in accordance with this standard is measured as ψ_c (critical CTOA value) and/or δ_5 (critical COD resistance curve) as a function of crack extension. Both fracture resistance parameters are characterized using either a single-specimen or multiple-specimen procedures. These fracture quantities are determined under the opening mode (Mode I) of loading. Influences of environment and rapid loading rates are not covered in this standard, but the user must be aware of the effects that the loading rate and laboratory environment may have on the fracture behavior of the material.

1.2 Materials that are evaluated by this standard are not limited by strength, thickness, or toughness, if the crack-length-to-thickness (a/B) ratio and the ligament-to-thickness (b/B) ratio are greater than or equal to 4, which ensures relatively low and similar global crack-front constraint for both the C(T) and M(T) specimens (**2**, **3**).

1.3 The values stated in SI units are to be regarded as the standard. The values given in parentheses (English) are for information purposes only.

1.4 *This standard does not purport to address all of the safety concerns, if any, associated with its use. It is the*

¹ This test method is under the jurisdiction of ASTM Committee E08 on Fatigue and Fracture and is the direct responsibility of Subcommittee E08.07 on Fracture Mechanics.

Current edition approved June 15, 2006. Published August 2006. DOI: 10.1520/E2472-06E01.

² The boldface numbers in parentheses refer to the list of references at the end of this standard.

responsibility of the user of this standard to establish appropriate safety and health practices and determine the applicability of regulatory limitations prior to use.

2. Referenced Documents

2.1 ASTM Standards:³

- E4 Practices for Force Verification of Testing Machines
- E8 Test Methods for Tension Testing of Metallic Materials
- E399 Test Method for Linear-Elastic Plane-Strain Fracture Toughness K_{Ic} of Metallic Materials
- E561 Test Method for $K-R$ Curve Determination
- E647 Test Method for Measurement of Fatigue Crack Growth Rates
- E1290 Test Method for Crack-Tip Opening Displacement (CTOD) Fracture Toughness Measurement
- E1820 Test Method for Measurement of Fracture Toughness
- E1823 Terminology Relating to Fatigue and Fracture Testing
- E2309 Practices for Verification of Displacement Measuring Systems and Devices Used in Material Testing Machines

2.2 ISO Standards:

- ISO/TC164/SC4-N413.4 Metallic Materials—Method of Test for the Determination of Resistance to Stable Crack Extension Using Specimens of Low Constraint⁴
- ISO 12135 Metallic Materials—Unified Method of Test for the Determination of Quasistatic Fracture Toughness⁴

3. Terminology

3.1 Terminology E1823 is applicable to this test standard.

3.2 Definitions:

3.2.1 *crack extension*, Δa [L], n —an increase in crack length.

3.2.1.1 *Discussion*—It should be noted that in thin-sheet and thick-plate materials under low constraint conditions, the crack extension observed on the surface of the specimen may be

³ For referenced ASTM standards, visit the ASTM website, www.astm.org, or contact ASTM Customer Service at service@astm.org. For *Annual Book of ASTM Standards* volume information, refer to the standard's Document Summary page on the ASTM website.

⁴ Available from American National Standards Institute (ANSI), 25 W. 43rd St., 4th Floor, New York, NY 10036.

significantly less than that in the interior of the specimen due to the effects of crack tunneling. This must be considered if direct optical techniques are used to monitor and measure free-surface crack extension. Indirect crack extension measurement techniques such as unloading compliance and electric-potential drop method may be used in place of (or to augment) the direct optical techniques to provide a measure of average crack extension. (See Test Method E647 for compliance methods for C(T) and M(T) specimens; and ISO 12135 for electric potential-drop methods for C(T) specimens.)

3.2.2 *crack length, a [L], n* —a linear measure of a principal planar dimension of a crack. This measure is commonly used in the calculation of quantities descriptive of the stress and displacement fields of cracked specimens.

3.2.2.1 *Discussion*—A measure of the crack length after the fatigue pre-cracking stage is denoted as the original crack length, a_o . The value for a_o may be obtained using surface measurement, unloading compliance, electric-potential drop or other methods where validation procedures for the measurements are available.

3.2.3 *crack-tip-opening angle (CTOA), ψ [deg], n* —relative angle of the crack surfaces measured (or calculated) at 1-mm behind current crack tip, where $\psi = 2 \tan^{-1}(\text{CTOD}/2)$.

3.2.4 *critical crack-tip-opening angle (CTOAc), ψ_c [deg], n* —steady-state value of CTOA measured (or calculated) at 1-mm behind the current crack tip, where $\text{CTOAc} = 2 \tan^{-1}(\text{CTOD}_c/2)$.

3.2.4.1 *Discussion*—The critical CTOA value tends to approach a constant, steady-state value after a small amount of crack extension (associated with crack tunneling and transition from flat-to-slant crack extension).

3.2.5 *crack-opening displacement, δ_5 [L], n* —relative displacement of the crack surfaces normal to the original (undeformed) crack plane at the tip of the fatigue pre-crack length, a_o . In this standard, δ_5 is measured at the original crack length location over a gage length of 5-mm as the crack stably tears.

3.2.6 *crack-tip-opening displacement (CTOD), δ [L], n* —relative displacement resulting from the total deformation (elastic plus plastic) at variously defined locations near the original (prior to force application) crack tip.

3.2.7 *critical crack-tip-opening displacement (CTOD_c), δ_c [L], n* —steady-state value of CTOD resulting from the total deformation (elastic plus plastic) measured (or calculated) at 1-mm behind current crack-tip location.

3.2.8 *crack extension resistance curve (R curve), n* —variation of δ_5 with crack extension, Δa .

3.2.9 *effective yield strength, σ_y [FL⁻²], n* —an assumed value of uniaxial yield strength that represents the influence of plastic yielding upon fracture test parameters.

3.2.9.1 *Discussion*—Effective yield strength is calculated as the average of the 0.2 % offset yield strength σ_{yS} , and the ultimate tensile strength, σ_{TS} as follows:

$$\sigma_y = (\sigma_{yS} + \sigma_{TS})/2 \quad (1)$$

NOTE 1—The yield and ultimate tensile strength are determined from Test Methods E8.

3.2.9.2 *Discussion*—In estimating σ_y , influences of testing conditions, such as loading rate and temperature, should be considered.

3.2.10 *final crack length, a_f [L], n* —crack extension at end of stable tearing ($a_f = a_o + \Delta a_p$).

3.2.11 *final remaining ligament, b_f [L], n* —distance from the tip of the final crack length to the back edge of the specimen, that is $b_f = W - a_f$.

3.2.12 *force, P [F], n* —force applied to specimen.

3.2.13 *minimum crack extension, Δa_{min} [L], n* —crack extension beyond which ψ_c is nearly constant.

3.2.14 *maximum crack extension, Δa_{max} [L], n* —crack extension limit for ψ_c and δ_5 controlled crack extension.

3.2.15 *maximum fatigue force, P_f [F], n* —maximum fatigue force applied to specimen during pre-cracking stage.

3.2.16 *modulus of elasticity, E [FL⁻²], n* —the ration of stress to corresponding strain below the proportional limit.

3.2.17 *notch length, a_n [L], n* —the distance from a reference plane to the tip of the machined notch, such as the load line in the compact-tension specimen to the notch tip or from the center line in the middle-crack tension specimen to the notch tip.

3.2.18 *original crack length, a_o [L], n* —the physical crack length at the start of testing.

3.2.19 *original remaining ligament, b_o [L], n* —distance from the original crack front to the back edge of the specimen, that is $b_o = W - a_o$.

3.2.20 *remaining ligament, b [L], n* —distance from the crack front to the back edge of the specimen, that is $b = W - a$.

3.2.21 *specimen thickness, B [L], n* —the side-to-side dimension of the specimen being tested (side grooving is not allowed).

3.2.22 *specimen width, W [L], n* —a physical dimension on a test specimen measured from a reference position, such as the load line in the compact-tension specimen or the center line in the middle-crack tension specimen to the edge of the specimen. (Note that the total width of the M(T) specimen is defined as $2W$.)

4. Summary of Test Method

4.1 The objective of this standard is to induce stable crack extension in a fatigue pre-cracked, low-constraint test specimen while monitoring and measuring the COD at the original fatigue pre-crack tip location (4, 5) or the CTOA (or CTOD) at 1-mm behind the stably tearing crack tip (6, 7), or both. The resistance curve associated with the δ_5 measurements and the critical limiting value of the CTOA measurements are used to characterize the corresponding resistance to stable crack extension. In contrast, the CTOD values determined from Test Method E1290 (high-constraint bend specimens) are values at one or more crack extension events, such as the CTOD at the onset of brittle crack extension with no significant stable crack extension.

4.2 Either of the fatigue pre-cracked, low-constraint test specimen configurations specified in this standard (C(T) or

M(T)) may be used to measure or calculate either of the fracture resistance parameters considered. The fracture resistance parameters, CTOA (or CTOD) and δ_5 , may be characterized using either a single-specimen or multiple-specimen procedure. In all cases, tests are performed by applying slowly increasing displacements to the test specimen and measuring the forces, displacements, crack extension and angles realized during the test. The forces, displacements and angles are then used in conjunction with certain pre-test and post-test specimen measurements to determine the material's resistance to stable crack extension.

4.3 Four procedures for measuring crack extension are: surface visual, unloading compliance, electrical potential, and multiple specimens.

4.4 Two techniques are presented for measuring CTOA: optical microscopy (OM) (8) and digital image correlation (DIC) (9).

4.5 Three techniques are presented for measuring COD: δ_5 clip gage (5), optical microscopy (OM) (8), and digital image correlation (DIC) (9).

4.6 Data generated following the procedures and guidelines contained in this standard are labeled qualified data and are insensitive to in-plane dimensions and specimen type (tension or bending forces), but are dependent upon sheet or plate thickness.

5. Significance and Use

5.1 This test method characterizes a metallic material's resistance to stable crack extension in terms of crack-tip-opening angle (CTOA), ψ and/or crack-opening displacement (COD), δ_5 under the laboratory or application environment of interest. This method applies specifically to fatigue pre-cracked specimens that exhibit low constraint and that are tested under slowly increasing displacement.

5.2 When conducting fracture tests, the user must consider the influence that the loading rate and laboratory environment may have on the fracture parameters. The user should perform a literature review to determine if loading rate effects have been observed previously in the material at the specific temperature and environment being tested. The user should document specific information pertaining to their material, loading rates, temperature, and environment (relative humidity) for each test.

5.3 The results of this characterization include the determination of a critical, lower-limiting value, of CTOA (ψ_c) or a resistance curve of δ_5 , a measure of crack-opening displacement against crack extension, or both.

5.4 The recommended specimens are the compact-tension, C(T), and middle-crack-tension, M(T), specimens.

5.5 Materials that can be evaluated by this standard are not limited by strength, thickness, or toughness, if the crack-length-to-thickness (a/B) ratio or ligament-to-thickness (b/B) ratio are equal to or greater than 4, which ensures relatively low and similar global crack-front constraint for both the C(T) and M(T) specimens (2, 3).

5.6 The values of CTOA (and COD (δ_5)) determined by this test method may serve the following purposes:

5.6.1 In research and development, CTOA_c (ψ_c) or COD (δ_5), or both, testing can show the effects of certain parameters on the resistance to stable crack extension of metallic materials significant to service performance. These parameters include, but are not limited to, material thickness, material composition, thermo-mechanical processing, welding, and thermal stress relief.

5.6.2 For specifications of acceptance and manufacturing quality control of base materials.

5.6.3 For inspection and flaw assessment criteria, when used in conjunction with fracture mechanics analyses. Awareness of differences that may exist between laboratory test and field conditions is required to make proper flaw assessment.

5.6.4 The critical CTOA (ψ_c) has been used with the elastic-plastic finite-element method to accurately predict structural response and force carrying capacity of simple and complex cracked structural components, see Appendix X1.

5.6.5 The δ_5 parameter has been related to the J-integral by means of the Engineering Treatment Model (ETM) (10) and provides an engineering approach to predict the structural response and force carrying capacity of cracked structural components.

5.6.6 The K-R curve method (Practice E561) is similar to the δ_5 -resistance curve, in that, the concept has been applied to both C(T) and M(T) specimens (under low-constraint conditions) and the K-R curve concept has been used successfully in industry (11). However, the δ_5 parameter has been related to the J-integral and the parameter incorporates the material non-linear effects in its measurement. Comparisons have also been made among various fracture criteria on fracture of C(T), M(T) and a structurally configured crack configuration (12) that were made of several different materials (two aluminum alloys and a very ductile steel), and the K-R curve concept was found to have limited application, in comparison to the critical CTOA_c (ψ_c) concept.

6. Apparatus

6.1 This procedure involves measurement of applied force, P , crack extension, Δa , and crack-opening displacement at the original fatigue crack tip location or crack-tip-opening angle at the current crack tip, or both. Testing is performed under crosshead displacement control in a tension-testing machine that conforms to the requirements of Practice E4.

6.1.1 *Calibration*—Calibration of all measuring apparatus shall be traceable either directly or indirectly via a hierarchical chain to an accredited calibration laboratory.

6.1.2 *Force Application*—The combined force sensing and recording devices shall conform to ASTM standards, such as Practices E4 and E2309. The test machine shall operate at a constant displacement rate. A force measuring system of nominal capacity exceeding $1.2P_L$ shall be used, where:

$$P_L = B (W - a_o)^2 \sigma_{TS} / (2W + a_o) \quad \text{for compact - tension specimen} \quad (2)$$

$$P_L = 2B (W - a_o) \sigma_{TS} \quad \text{for middle - crack - tension specimen} \quad (3)$$

6.2 *Fixturing for the Compact Tension [C(T)] Specimens*—Compact-tension specimens shall be loaded using a clevis and

pin arrangement designed to minimize friction. The arrangement shall ensure load train alignment as the specimen is loaded in tension. A loading clevis suitable for testing C(T) specimens is shown in Fig. 1. Each leg of the specimen is held by such a clevis and loaded through pins, in order to allow rotation of the specimen during testing. To provide rolling contact between the loading pins and the clevis holes, these holes are produced with small flats on the loading surfaces. Other clevis designs may be used if it can be demonstrated that they will accomplish the same result as the design shown. Round-bottomed holes shall not be allowed for single specimens (unloading compliance) tests because pin movement may be restricted. Clevises and pins should be fabricated from steels of sufficient strength and hardness (greater than 40 HRC (400 HV)) to elastically resist indentation forces. The critical tolerances and suggested proportions of the clevis and pins are given in Fig. 1. The pin diameter is $0.24W (+0.000W/-0.005W)$. The particular configuration and dimensions in the gripping area should be selected by the user to match the test machine fixtures and capabilities. These proportions are based on specimens having $W/B = 8$. If a 1900-MPa (275 000-psi) yield strength maraging or stainless steel is used for the clevis and pins, adequate strength will be obtained. If lower strength grip material is used, or if substantially larger specimens are required at a given σ_{YS}/E ratio, then heavier grips may be required. Attention should be given to achieving good alignment through careful machining of all auxiliary gripping fixtures. All specimens shall be tested with anti-buckling guide plates, as shown in Fig. 2. The anti-buckling guide plates must cover a large portion of the specimen. Placing thin sheets of a low friction material, such as TFE-fluorocarbon, between the anti-buckling plates and the specimen surface, and only hand-tightening the perimeter bolts has been shown to provide adequate stability while minimizing friction. As shown in Fig. 2, openings must be machined into the anti-buckling plates in the appropriate locations to allow for the monitoring and measuring of crack extension and the crack-tip-opening angles and δ_5 . Measurement of crack-mouth-opening displacements using a clip gage may be made to determine crack length using the unloading compliance method.

6.3 Fixturing for the Middle-Crack Tension [M(T)] Specimens—Middle-crack tension specimens shall be loaded using hydraulically-clamped or bolted grips designed to carry the applied force in friction. Bolt bearing should be avoided to minimize non-uniform loading. The arrangement shall ensure alignment of the specimen to minimize in-plane and out-of-plane bending. All specimens shall be tested with anti-buckling guide plates, as shown in Fig. 3. The anti-buckling guide plates must cover a large portion of the specimen. Support only along the crack plane has been shown to be insufficient to prevent buckling between the grip lines and the crack plane for thin-sheet materials. Flat plates, as shown in Fig. 3(a), are sufficient for small M(T) specimens ($2W < 600$ mm), but flat plates stiffened with I-beams, as illustrated in Fig. 3(b), have been shown to be required for M(T) specimens with widths ($2W$) larger than about 600 mm. As shown in Fig. 3, gap(s) are

left in the anti-buckling plates on either one or both sides of the specimen to allow for the monitoring and measuring of crack extension and the crack-tip-opening angles, and δ_5 . Measurement of crack-mouth opening displacements using a clip gage may also be made to determine crack length using the unloading compliance method.

6.4 Crack Extension Measurement—Several methods can be used to monitor and measure crack extension: (1) direct optical method, (2) unloading compliance method, (3) electric-potential-drop method, and (4) the multiple-specimen method. Indirect crack extension measurement techniques, such as unloading compliance and electric-potential-drop methods may be used in place of (or to augment) the direct optical method to provide a measure of average through-the-thickness crack extension. The multiple-specimen method is used to provide information on the extent of tunneling and to determine a three-point ($B < 5$ mm) or five-point ($B > 5$ mm) weighted average crack extension.

6.4.1 Direct Optical Method—The direct optical method measures the crack length and crack extension on the specimen free surface using optical microscopes. It should be noted that in thin-sheet materials and low constraint specimens, the crack extension observed on the free surface of the specimen may be significantly less than that on the interior of the specimen due to the effects of crack tunneling. This must be kept in mind if direct optical techniques are used to monitor and measure free-surface crack extension.

6.4.2 Unloading Compliance Method—By the unloading compliance method, a specimen is partially unloaded and then reloaded at specified intervals during the test. The unloading slopes, which tend to be linear and independent of prior plastic deformation, are used to estimate the crack length at each unloading from analytical elastic compliance relationships. The specimen compliance is determined from either crack-mouth-opening or load-point compliance, and the crack length is estimated using compliance equations (see Test Methods E647 and E1820). If the displacement is measured at an alternative point, then the appropriate compliance function must be developed and utilized. Errors may occur in the compliance measurement as a result of displacement-gage transducer non-linearity. Significant improvement in accuracy can be achieved by curve-fitting the lowest-order polynomial function possible through the calibration data. This method is ideally suited to computer control and subsequent analysis of the test data. However, it should be noted that the method requires careful experimentation and sophisticated test equipment in order to realize its full capability.

6.4.3 Electric Potential Drop Method—The electrical potential method (13-16) relies on the fact that the distribution of electrical potential in the vicinity of a crack changes with crack extension. With suitable instrumentation, the changes in potential can be detected and calibrated to provide an estimate of increase in crack length. The applied potential is either direct or alternating and the procedure referred to as either the D.C. or the A.C. potential technique, respectively. This method is ideally suited to computer control and subsequent analysis of

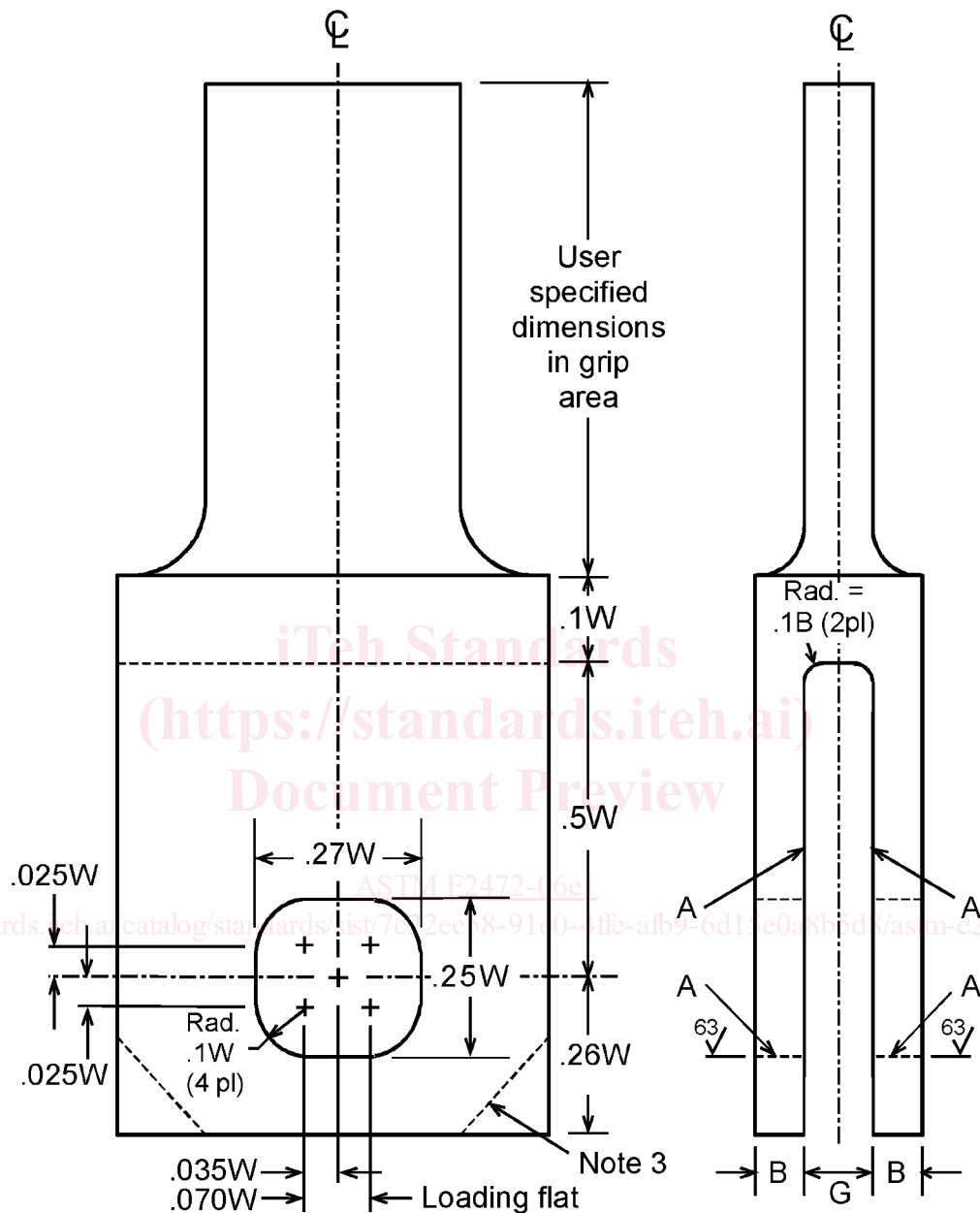

- Note 1 - A Surfaces must be flat, in-line and perpendicular, as applicable, to within 0.05 mm (0.002 in.) T.I.R.
- Note 2 - Value of G must include maximum expected specimen thickness, B, plus twice the guide plate thickness, and extra space for free fixture rotation.
- Note 3 - Corners may be removed as necessary to accomodate clip gage.

FIG. 1 Clevis for Compact Tension, C(T), Specimen Testing

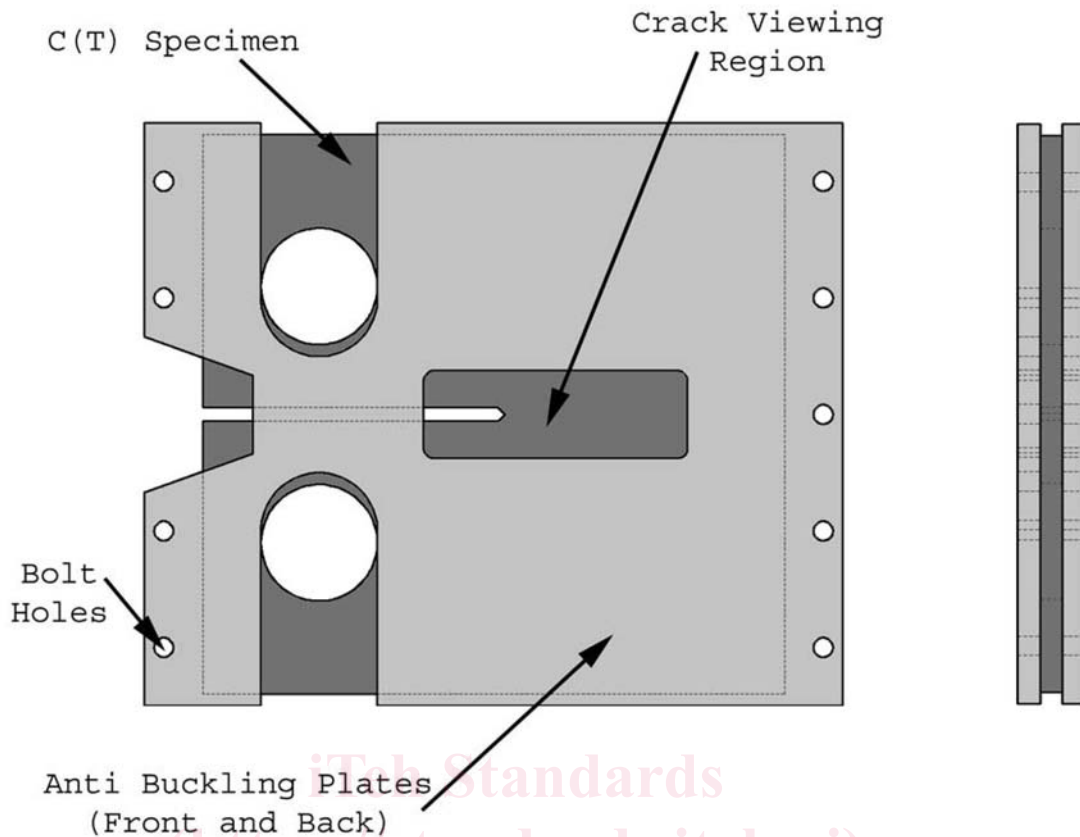

FIG. 2 Compact Tension, C(T), Specimen with Anti-Buckling Guides

the test data. However, it should be noted that the method requires careful experimentation and sophisticated test equipment in order to realize its full capability. (See ISO 12135 for descriptions of the electric-potential drop methods for the C(T) specimen.)

6.4.4 Multiple-Specimen Method—The multiple-specimen method relies on fatigue marking, heat-tinting, or other means to mark the crack front after stable tearing. The multiple-specimen method is used to provide information on the extent of tunneling and to determine a three-point ($B < 5$ mm) or five-point ($B > 5$ mm) weighted average crack extension.

6.5 Force Measurement—The sensitivity of the force-sensing device shall be sufficient to avoid distortion caused by over amplification. The combination of force sensing device and recording system shall permit the maximum force (P) to be determined from the test record within an accuracy of ± 1 %.

6.6 Displacement and Angle Measuring Technique—This test method covers the characterization of resistance to stable crack extension in fatigue pre-cracked (at low ΔK levels), low-constraint test specimens. Two methods are introduced to provide this characterization, the first is based on the crack-tip-opening angle (CTOA), ψ , and the second is based on a measure of crack-opening displacement (COD), δ_5 . Both methods can be carried out using either a single-specimen or multiple-specimen procedure. In the following sections, these two characterizations techniques will be discussed in parallel.

6.6.1 Crack-Tip-Opening Angle Measurement—This procedure involves the displacement-controlled loading of a fatigue pre-cracked, low-constraint specimen C(T) or M(T) while simultaneously measuring the applied force (P), crack extension (Δa) and crack-tip-opening angle (CTOA) measured 1 mm behind the current crack tip. Several methods can be used to determine CTOA: (1) direct measurements during stable tearing using optical methods (8, 9), (2) post test measurements (microtopography) (17-19), (3) finite element analyses (6-8, 20-26), and (4) indirect determination using δ_5 . The two techniques that are used for direct measurement of ψ (CTOA) during stable tearing of cracks are the Optical Microscopy (OM) (8) and Digital Image Correlation (DIC) (8, 9) methods. Both of these methods produce nearly identical CTOA results (8, 20).

6.6.1.1 Optical Microscopy (OM) Method—This method includes: (a) a long focal length microscope, (b) a high-resolution video camera with resolution of 512 by 512 pixels (or better) to obtain images of the stably tearing crack, (c) a recording mechanism to store the images (PC or video recorder), and (d) a personal computer with both monitor and software to precisely control the three-dimensional positioning of the long focal length microscope and also to analyze the images to obtain CTOA. A transverse magnification of approximately 320 pixels per mm has been shown to provide satisfactory results. To obtain clear images of the crack using

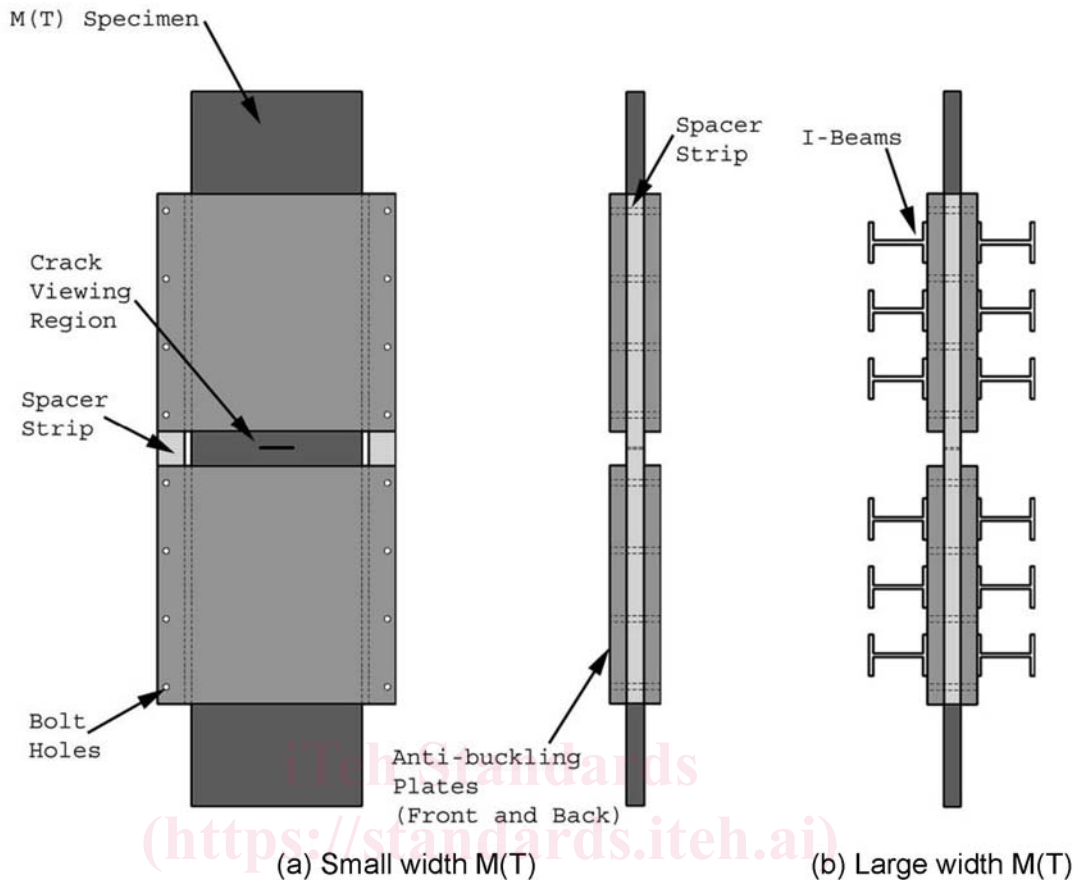

FIG. 3 Middle-Crack Tension, M(T), Specimen with Anti-Buckling Guides

OM, the surface of the specimen must be polished to a mirror finish and lighting of the crack region must be carefully controlled so that the crack tip region has optimum contrast and clarity. Recommended procedures to measure CTOA using this method will be discussed in 9.1.1 of this document.

6.6.1.2 *Digital Image Correlation (DIC) Method*—This method includes: (a) a video camera, (b) a lens system to obtain the appropriate level of magnification (for example, a 200 mm lens with 2× magnifier and several extension tubes has been used effectively in previous applications), (c) translation stage for positioning of the video camera and following the growing crack, (d) video monitor to view the crack tip region, (e) video board to digitize images, and (f) a microcomputer with software for controlling the image acquisition process and storing images. The DIC method is similar to previously reported image correlation systems, except that in this case the video camera is translated parallel to the specimen surface during the experiment so that the current crack tip remains within the field of view. Note that, after each translation of the video camera, the current image and previous image overlap by at least 50 pixels so that a continuous record of crack length is maintained if the crack grows beyond the current field of view. Recommended procedures to measure CTOA using this method will be discussed in 9.1.2 of this document.

6.6.2 *Crack-Opening Displacement, δ_5 , Measurement*—This procedure involves the displacement-controlled loading of

a fatigue pre-cracked, low-constraint specimen [C(T) or M(T)] while simultaneously measuring the applied force (P), crack extension (Δa), and crack-opening displacement (δ_5) measured at the original fatigue crack tip location.

6.6.2.1 *Clip-Gage Method*—This method includes a displacement gage for the determination of δ_5 at the original fatigue crack tip location and shall have an electrical output that represents the displacement between two precisely located gage positions 5-mm apart and spanning the crack at the original fatigue crack tip location. The basic arrangement for measuring δ_5 is shown in Fig. 4. The area around the expected fatigue pre-crack path is to be polished. After fatigue pre-cracking, Vickers hardness indentations are placed 2.5 mm to either side of the crack tip to give a gage length of 5 mm. A clip gage with needle tips is seated into the hardness indentations and held against the specimen using the lever mechanism shown in Fig. 5 for the compact-tension specimen. Similar arrangements and clip-gage fixtures are used for middle-crack-tension specimens. The recommended displacement gage configuration and dimensions are shown in Fig. 6. The displacement gage has a working range of not more than twice the displacement expected during the test. When the expected displacement is less than 3.75 mm (0.15 in.), the gage recommended in Fig. 6 may be used. When a greater working range is needed, an enlarged gage or the optical methods are recommended. Accuracy shall be within $\pm 1\%$ of the full

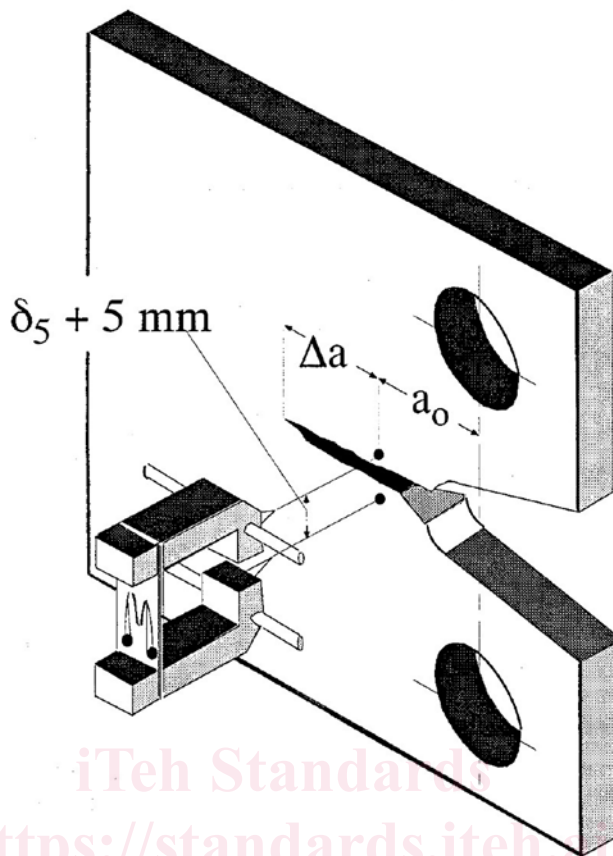

FIG. 4 Basic Clip Gage and Specimen Arrangement for Measuring δ_5

working range. In calibration, the maximum deviation of the individual data points from a linear fit to the data shall be less than $\pm 0.3\%$ of the working range of the gage. Vickers hardness indentations at 5-mm gage length are required for seating the gage. The displacement gage should be removed from the specimen before the specimen fails. Recommended procedures to measure δ_5 -resistance curves using this method will be discussed in 9.2 of this document.

6.6.2.2 *Digital Image Correlation (DIC) Method*—This method includes: (a) a video camera, (b) a lens system to obtain the appropriate level of magnification (for example, a 200 mm lens with 2 \times magnifier and several extension tubes has been used effectively in previous applications), (c) a translation stage for positioning of the video camera and following the growing crack, (d) video monitor to view the crack tip region, (e) video board to digitize images, and (f) microcomputer with software for controlling the image acquisition process and storing images. The DIC method is similar to previously reported systems, except that the video camera remains stationary so that the original crack tip remains within the field of view. Recommended procedures to measure δ_5 -resistance curves using this method will be discussed in 9.2 of this document.

6.6.2.3 *Optical Microscopy (OM) Method*—This method includes: (a) a long focal length microscope positioned at the original crack-tip location, (b) a high-resolution video camera with resolution of 512 by 512 pixels (or better) to obtain

images of the displacement field, (c) a recording mechanism to store the images (PC or video recorder), and (d) a personal computer with both monitor and software to measure the δ_5 -displacement. After fatigue pre-cracking, Vickers hardness indentations are placed 2.5 mm to either side of the crack tip to give a gage length of 5 mm. The displacement of the indentation marks is measured as a function of the applied force and crack extension. Recommended procedures to measure δ_5 -resistance curves using this method will be discussed in 9.2 of this document.

7. Specimen Configuration, Dimensions, and Preparation

7.1 Materials that can be evaluated by this standard are not limited by strength, thickness, or toughness, if the crack-length-to-thickness (a/B) ratio or ligament-to-thickness (b/B) ratio are equal to or greater than 4, which ensures relatively low and similar global crack-front constraint for both the C(T) and M(T) specimens.

NOTE 2—The total width of the M(T) specimen is defined as 2W.

7.2 *Specimen Configurations*—The crack configurations of the standard specimens are shown in Annex A1 and Annex A2. To produce a reliable critical CTOA (ψ_c) and a large amount of the δ_5 -resistance curve, the specimens have a minimum width (W) of 150 mm.

7.3 *Crack Plane Orientation*—The crack plane orientation shall be considered in preparing the test specimen. The

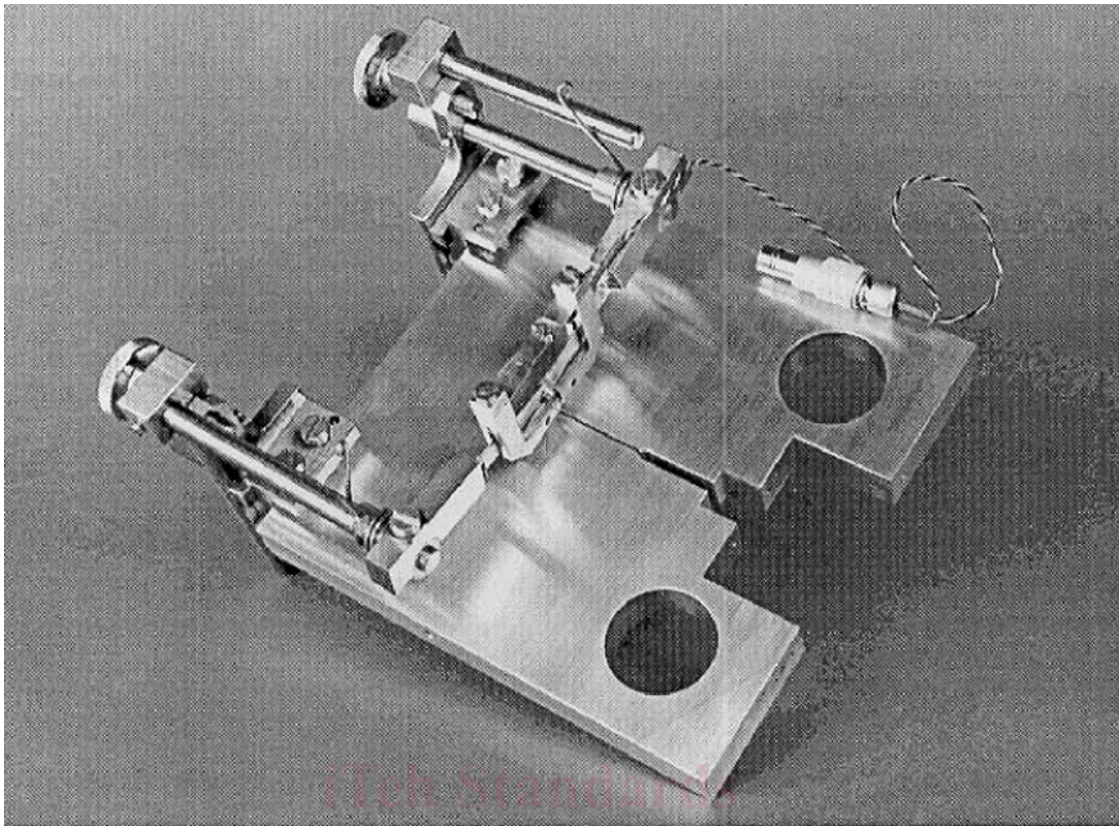

FIG. 5 Fixtures for Attachment of the δ_5 Clip Gage to Compact-Tension Specimen

orientation of the crack plane in the material of interest can affect the critical crack-opening displacement parameters considered in this standard. This is discussed in Terminology E1823.

7.4 *Specimen Pre-cracking*—All specimens shall be pre-cracked in fatigue. Experience has shown that it is impractical to obtain a reproducibly sharp, narrow machined notch that will simulate a natural crack well enough to provide a satisfactory fracture toughness test result. The most effective artifice for this purpose is a narrow notch from which extends a comparatively short fatigue crack, called the pre-crack. (A fatigue pre-crack is produced by cyclically loading the notched specimen for a number of cycles usually between about 10^4 and 10^6 depending on specimen size, notch preparation, and stress intensity level.) The dimensions of the notch and the pre-crack, and the sharpness of the pre-crack shall meet certain conditions that can be readily met with most engineering materials, since the fatigue cracking process can be closely controlled when careful attention is given to the known contributory factors. However, there are some materials that are too brittle to be fatigue-cracked, since they fracture as soon as the fatigue crack initiates; these are outside the scope of the present test method.

7.4.1 *Fatigue Crack Starter Notch*—Several forms of fatigue crack starter notches are shown in Fig. 7. The notch height, N , is equal to or less than 5 mm. The notch configurations shall not exceed the envelope, as shown by the dashed

lines in Fig. 7. In the case of an electrical-discharge machined slot or a slot with a drilled hole at the tip, it will be necessary to provide a sharp stress raiser at the end of the slot or hole. To facilitate fatigue cracking at low stress-intensity factor levels, the root radius for a straight-through slot terminating in a V-notch should be 0.08 mm (0.003 in.) or less.

7.4.2 *Fatigue Crack Length*—The fatigue crack length from the notch tip shall be equal to or exceed the envelope, as shown by the dashed lines in Fig. 7. The fatigue crack extension, Δa , shall be equal to or greater than $2N$, but not less than 1.3-mm in length.

7.4.3 *Equipment and Fixtures*—The equipment and fixtures used for fatigue cracking should be such that the stress distribution through the specimen thickness is uniform (no out-of-plane bending); otherwise the crack will not grow uniformly. The stress distribution should also be symmetrical about the plane of the prospective crack (no shear mode stress intensity factors); otherwise the crack may deviate from that plane and the test result can be significantly affected. Fixtures used for fatigue cracking should be machined with the same tolerances as those used for testing.

7.4.4 *Fatigue Pre-cracking Procedure*—Fatigue pre-cracking shall be performed with the material in the finally heat-treated, mechanically worked, or environmentally conditioned state. Intermediate treatments between fatigue pre-cracking and testing are acceptable only when such treatments are necessary to simulate the conditions of a specific structural

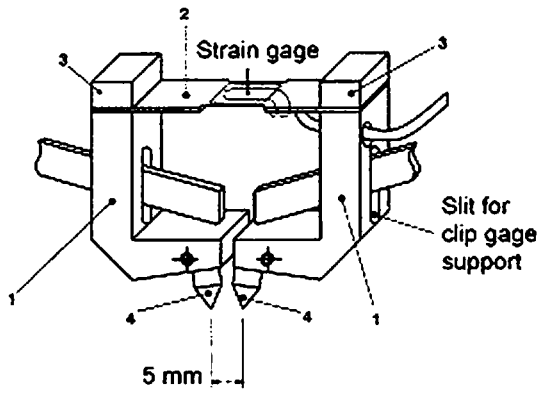

(a) Overall δ_5 clip gage design

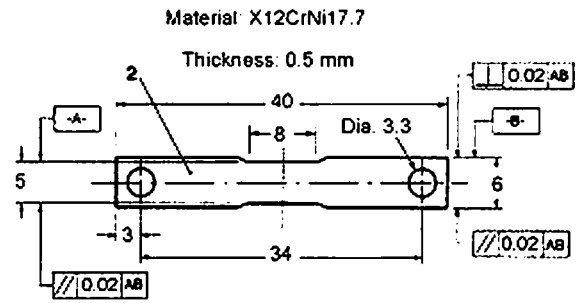

(b) Clip gage spring

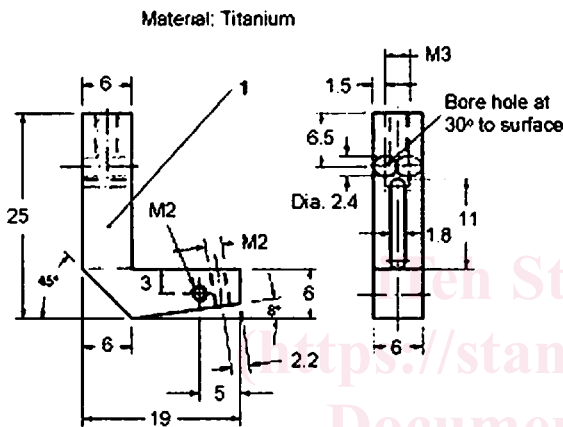

(c) Clip gage arms

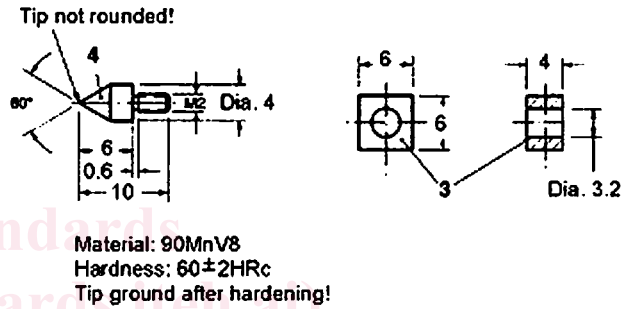

(d) Clip gage tips

(All dimensions in mm.)

FIG. 6 Crack-Opening Displacement, δ_5 , Clip Gage Design

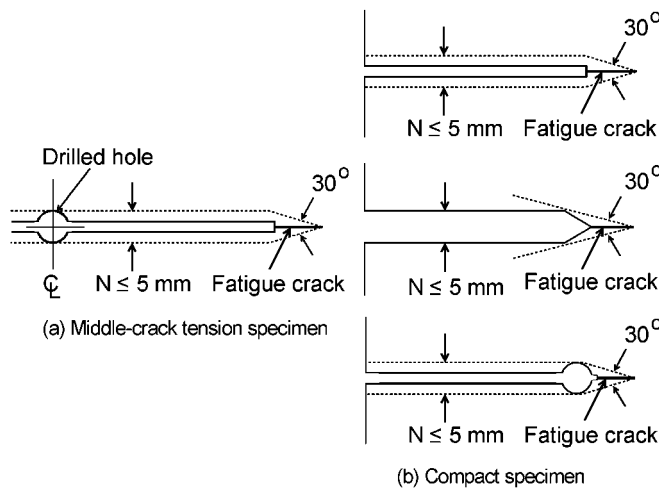

FIG. 7 Envelope of Fatigue Crack Starter Notch Configurations

application; such departure from recommended practice shall be explicitly reported.