



# Standard Specification for Helmets Used for Recreational Snow Sports<sup>1</sup>

This standard is issued under the fixed designation F2040; the number immediately following the designation indicates the year of original adoption or, in the case of revision, the year of last revision. A number in parentheses indicates the year of last reapproval. A superscript epsilon ( $\epsilon$ ) indicates an editorial change since the last revision or reapproval.

## 1. Scope\*

1.1 This specification defines performance requirements for helmets used in nonmotorized recreational snow sports (such as skiing, snowboarding, and other alpine sports). This specification is a performance standard and is not intended to restrict design. Although a helmet that meets this specification will help reduce the risk of some types of injuries to the head at slower speeds, the protection is limited. The user is responsible for participating in the sport within his/her abilities and the nature of the snow conditions which may vary widely. Compliance with the common sense rules of the sport's safety, including any applicable responsibility codes, is essential to help reduce the risk of personal injury.

1.2 All testing and requirements of this specification shall be in accordance with Test Methods F1446, except where noted herein.

1.3 Partial utilization of this specification is prohibited. Any statement of compliance with this specification shall be a certification that the product meets all of the requirements of the specification in its entirety. A product that fails to meet any one of the requirements of this specification is considered to have failed the standard and should not be sold with any indication that it meets parts of the standard.

## 2. Referenced Documents

2.1 *ASTM Standards*:<sup>2</sup>

F1446 Test Methods for Equipment and Procedures Used in Evaluating the Performance Characteristics of Protective Headgear

## 3. Headforms

3.1 Headforms to be used in this specification are as specified in the section on Test Headforms of Test Methods

<sup>1</sup> This specification is under the jurisdiction of ASTM Committee F08 on Sports Equipment, Playing Surfaces, and Facilities and is the direct responsibility of Subcommittee F08.53 on Headgear and Helmets.

Current edition approved April 1, 2011. Published May 2011. Originally approved in 2000. Last previous edition approved in 2006 as F2040 – 06. DOI: 10.1520/F2040-11.

<sup>2</sup> For referenced ASTM standards, visit the ASTM website, www.astm.org, or contact ASTM Customer Service at service@astm.org. For *Annual Book of ASTM Standards* volume information, refer to the standard's Document Summary page on the ASTM website.

F1446. The appropriate size headform shall be selected in accordance with the section on Headform Size Selection of Test Methods F1446 for the helmet to be tested.

## 4. Anvils and Impact Velocities

4.1 Anvils to be used for impact tests in this specification are described as follows:

4.1.1 *Flat Anvil*, as described in the section on Apparatus of Test Methods F1446.

4.1.2 *Hemispherical Anvil*, as described in the section on Apparatus of Test Methods F1446.

4.1.3 *Edge Anvil*, constructed of solid steel in accordance with Fig. 1.

### 4.2 Impact Velocities:

4.2.1 Impacts upon the flat anvil shall achieve a velocity of 6.2 m/s (corresponding to a theoretical drop height of 2.0 m).

4.2.2 Impacts upon the hemispherical anvil shall achieve a velocity of 4.8 m/s (corresponding to a theoretical drop height of 1.2 m).

4.2.3 Impacts upon the edge anvil shall achieve a velocity of 4.5 m/s (corresponding to a theoretical drop height of 1.0 m).

4.2.4 The impact velocity shall be measured during the last 40 mm of free-fall for each test and shall be within 3 % of the velocities specified in 4.2.1, 4.2.2, and 4.2.3.

## 5. Marking the Test Line

5.1 The test line is shown in Fig. 2 and shall be marked in accordance with Test Methods F1446.

## 6. Conditioning and Number of Samples

6.1 Four sample helmets are required for each shell/liner size combination.

6.2 Conditioning of the samples to be tested is described in the section on Conditioning Environment of Test Methods F1446, but differs as follows:

6.2.1 *Low Temperature*—The low temperature shall be -22 to -28°C.

6.2.2 *High Temperature*—The high temperature shall be 32 to 38°C.

## 7. Impact Sites

7.1 Centers of impact can be located anywhere on or above the test line with the anvils aligned in any orientation.

\*A Summary of Changes section appears at the end of this standard

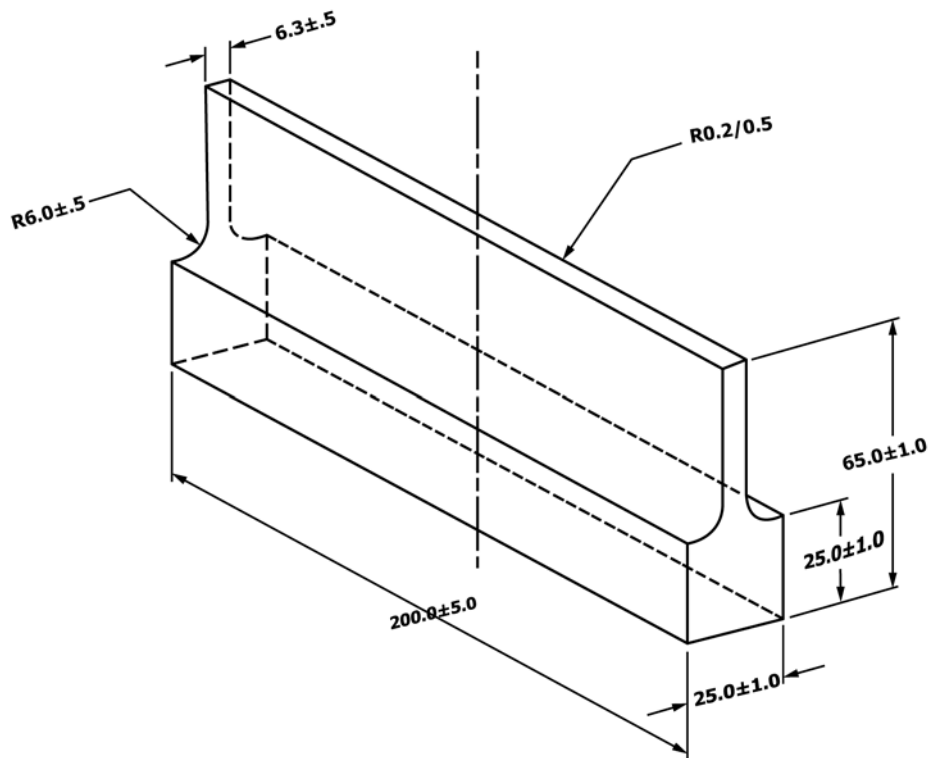

FIG. 1 Edge Anvil

7.2 The theoretical center<sup>3</sup> of each impact site shall be separated from the theoretical center of other impact sites by a minimum of 120 mm.

## 8. Impacting Schedule

8.1 All impacting shall be performed in accordance with the section on Impact Attenuation of Test Methods F1446.

8.2 Two of the four impact sites (as described in the section on Impact Attenuation of Test Methods F1446) will use the flat anvil.

8.3 One impact site will use the hemispherical anvil.

8.4 One impact site will use the edge anvil.

8.5 The impact sites and anvils can be selected in any sequence.

## 9. Peak Acceleration Requirements

9.1 The peak acceleration (g max) of the impulse during the impact shall be measured with equipment described in the section on Apparatus of Test Methods F1446.

9.2 The peak acceleration of any impact shall not exceed 300 g.

## 10. Retention System Testing

10.1 The Dynamic Strength Retention Test shall be completed in accordance with Test Methods F1446 prior to impact testing.

<sup>3</sup> The theoretical center of impact is the point of intersection of the Z-axis and the outer surface or projected surface of the helmet at  $x = 0$ ,  $y = 0$  (see X1.1 of Test Methods F1446).

10.2 *Dynamic Strength Retention Test*— The hot, cold, and wet helmets shall be subjected to the Dynamic Strength Retention Test. Place the helmet on the appropriate size headform on the test device described in the section on Apparatus of Test Methods F1446.

10.2.1 Place the twin bar (jaw) system with rod and drop weight attached within the fastened retention system.

10.2.2 Mark the position of the twin bar with preload and drop weights in position.

10.2.3 Drop a 4-kg sliding weight a distance of 0.6 m.

10.2.4 The retention system shall remain intact without elongating more than 30 mm.

10.3 The ambient helmet shall be subjected to the positional stability (roll-off) test in accordance with Test Methods F1446 using a 4 kg drop mass from a height of 0.6 m.

10.3.1 The retention system shall remain intact and the helmet shall remain on the headform.

## 11. Labels and Warnings

11.1 In addition to the labeling requirements of Test Methods F1446, the helmet shall have the words “for use in nonmotorized recreational snow sports (such as skiing, snowboarding, and other alpine sports)” inscribed on one of the interior permanent labels.

## 12. Keywords

12.1 helmet; protective headgear; skiing; snowboarding