



Standard Specification for Headforms¹

This standard is issued under the fixed designation F2220; the number immediately following the designation indicates the year of original adoption or, in the case of revision, the year of last revision. A number in parentheses indicates the year of last reapproval. A superscript epsilon (ϵ) indicates an editorial change since the last revision or reapproval.

INTRODUCTION

This specification identifies the headforms used for testing protective headgear in individual ASTM International test methods and performance standards (standard specifications). This specification was closely based on the ISO DIS 6220 that is no longer available (having been replaced by EN 960). It is not possible for ASTM International protective headgear standards to reference EN 960 because this standard makes no provisions for ASTM International impact headforms.

1. Scope

1.1 This standard specifies the materials, sizing, and manufacturing details of test headforms for use in the testing of protective headgear. Details of the exterior dimension of the headforms are included.

1.2 The values stated in SI units are to be regarded as standard. No other units of measurement are included in this standard.

2. Referenced Documents

2.1 *ASTM Standards:*²

B92/B92M [Specification for Unalloyed Magnesium Ingot and Stick For Remelting](#)

2.2 *Other Standards:*

EN 960 Headforms for Use in the Testing of Protective Helmets

3. Terminology

3.1 *Definitions:*

3.1.1 *basic plane, n*—an anatomical plane that includes the superior rim of the external auditory meatus (upper edge of the external openings of the ear) and the inferior margin of the orbit (the lowest point of the floor of the eye socket) (see Figs. 1 and 2).

3.1.2 *coronal plane, n*—an anatomical plane perpendicular to both the basic and midsagittal planes and passing through the superior rims of the right and left external auditory meatuses. The transverse plane corresponds to the coronal plane (see Figs. 1 and 2).

3.1.3 *impact headforms, n*—headforms used for impact testing of protective headgear. Impact headforms shall conform to the external dimension defined in this specification. These headforms shall meet the material, dimensions, mass, and center of gravity requirements of this specification. These headforms shall include surface markings corresponding to the basic, coronal, midsagittal, and reference planes.

3.1.4 *midsagittal plane, n*—an anatomical plane perpendicular to the basic plane and containing the midpoint of the line connecting the notches of the right and left inferior orbital ridges and the midpoint of the line connecting the superior rims of the right and left external auditory meatuses (see Figs. 1 and 2).

3.1.5 *other (reference) headforms, n*—headforms used for other testing, other than impact, of protective headgear. They shall conform to the external dimension requirements of each particular headform size, as specified in this specification. Reference headforms shall be made of material of sufficient strength and stiffness to maintain their geometry during testing. Full-chin headforms will be used as necessary. Reference headforms shall include surface markings corresponding to the basic, coronal,

¹ This specification is under the jurisdiction of ASTM Committee F08 on Sports Equipment and Facilities and is the direct responsibility of Subcommittee F08.53 on Headgear and Helmets.

Current edition approved Feb. 1, 2009. Published September 2009. Originally approved in 2002. Last previous edition approved in 2002 as F2220-02. DOI: 10.1520/F2220-02R09.

Current edition approved April 1, 2011. Published May 2011. Originally approved in 2002. Last previous edition approved in 2009 as F2220-02 (2009). DOI: 10.1520/F2220-11.

² For referenced ASTM standards, visit the ASTM website, www.astm.org, or contact ASTM Customer Service at service@astm.org. For *Annual Book of ASTM Standards* volume information, refer to the standard's Document Summary page on the ASTM website.

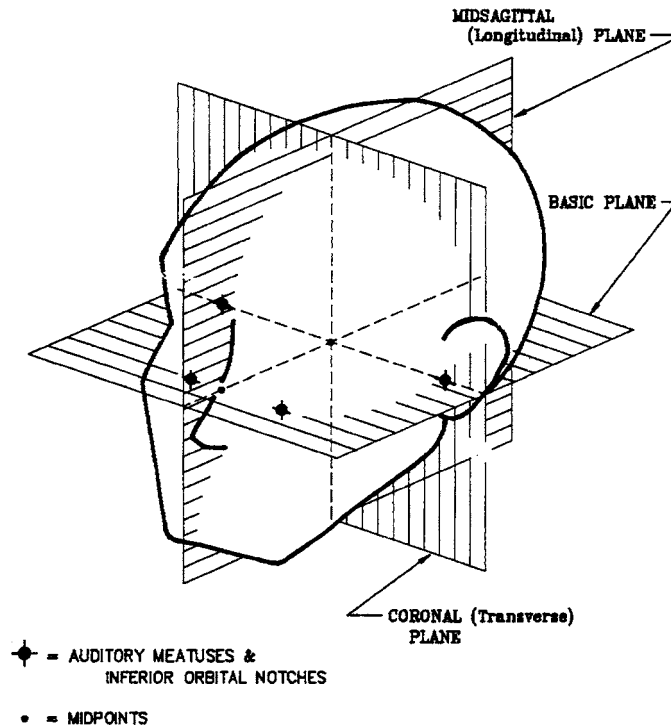

FIG. 1 Anatomical Planes

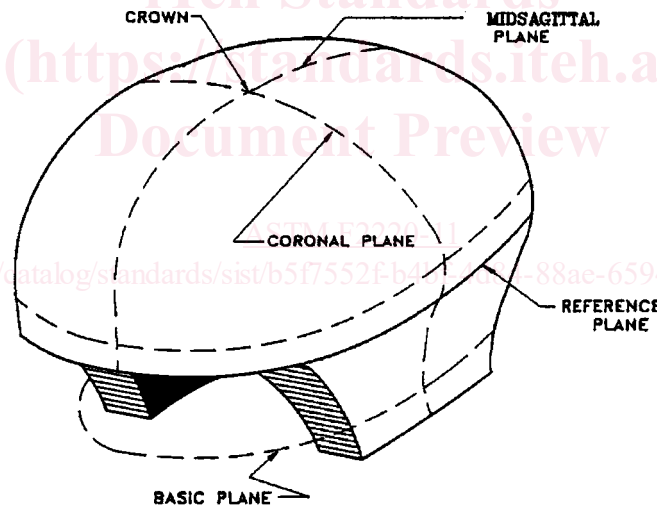

FIG. 2 Impact Headform—Basic, Reference, Midsagittal Planes

midsagittal, and reference planes and the vision points.

3.1.6 *reference plane, n*—a plane marked on the headforms at a specified distance above and parallel to the basic plane (see Fig. 2).

4. Classification

4.1 This specification identifies the requirements for five^{six} test headform sizes: A, C, E, J, M, and O. The size codes used for headforms relate to the nominal inside circumference of helmets (see Table 1). The nominal inside circumference values refer to the internal circumference of the helmet measured at a datum level 12.7 mm above the reference plane.

5. Dimensions

5.1 *Datum Levels*—All datum levels are quoted relative to the reference plane (“0” level) and are given in mm.

5.2 *Dimensions*—The external dimensions that the headforms must conform to are identified in Annex A1 and Annex A2. The headforms shall be symmetrical about the midsagittal plane. Internal geometry may be defined to satisfy the requirements of the individual test specifications. The resulting headform must still comply with the other requirements of this specification.

TABLE 1 Measurement for Headform Size

Headform-Size Label	Nominal Inside Circumference (circumference, mm)	Nominal Inside Circumference of Helmet (mm)
A		500
A	495	500
C	515	520
E		540
E	535	540
J		570
J	575	570
M		600
M	605	600
O	625	620

5.3 *Tolerances*—The tolerance on all linear dimensions is ± 0.25 mm.

6. Impact Headforms

6.1 *Materials and Manufacture*—The impact headforms shall be made of K1A-F magnesium (nominal composition 0.7 % Zr, balance Mg; Specification B92/B92M, Grade 9980A).

6.2 *External Dimensions*—Impact headforms shall comply with the exterior dimensions given in Annex A1. The polar coordinates of the horizontal half-sections at each datum level above the reference plane are given.

6.3 *Performance Requirements*—The impact headforms shall not have resonant frequencies below 2000 Hz.

6.4 *Mass*—The total mass of the drop assembly (including the instrumented headform and supporting assembly) shall be described in the specific test method for evaluating protective headgear. The mass of the impact headform may be adjusted to accommodate the specific test method requirements.

6.5 *Center of Gravity*—The center of gravity of the impact headform shall lie at a point on the central vertical axis, 12.7 mm above the reference plane.

6.6 *Product Marking*—All impact headforms shall be marked with:

6.6.1 Headform size;

6.6.2 Basic plane;

6.6.3 Reference plane; and

6.6.4 Midsagittal (longitudinal) and coronal (transverse) planes through the vertical axis.

7. Other (Reference) Headforms

7.1 *Materials and Manufacture*—Other headforms shall be made of material of sufficient strength and stiffness to maintain their geometry during testing.

7.2 *External Dimensions*—Other headforms shall comply with the external dimensions given in Annex A1 and Annex A2. The polar coordinates of the horizontal half-sections at each datum level are given.

7.2.1 *Product Marking*—All headforms shall be marked with:

7.2.1.1 Headform size;

7.2.1.2 Basic plane;

7.2.1.3 Reference plane;

7.2.1.4 Midsagittal (longitudinal) and coronal (transverse) planes through the vertical axis; and

7.2.1.5 Two points located on the basic plane equally spaced 31 mm each side of the point defined by the intersection of the basic and midsagittal planes at the front of the headform.

8. Keywords

8.1 headform(s); helmet(s); protective headgear

ANNEXES

(Mandatory Information)

A1. HEADFORM DATA ABOVE THE REFERENCE PLANE

A1.1

Dimensions in millimetres

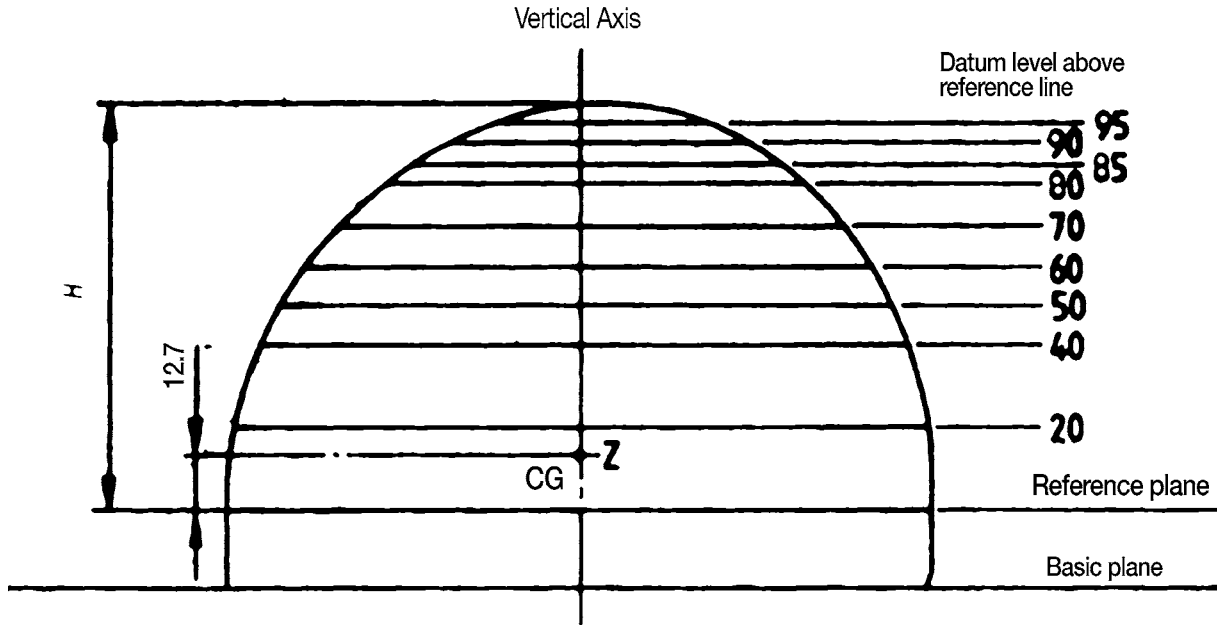

FIG. A1.1 Headform Datum Levels Above the Basic Plane

iteh Standards
 (https://standards.iteh.ai)
 Document Preview

[ASTM F2220-11](https://standards.iteh.ai/catalog/standards/sist/b5f7552f-b4bf-4d84-88ae-6594b1a0a84e/astm-f2220-11)

<https://standards.iteh.ai/catalog/standards/sist/b5f7552f-b4bf-4d84-88ae-6594b1a0a84e/astm-f2220-11>

Dimensions in millimetres

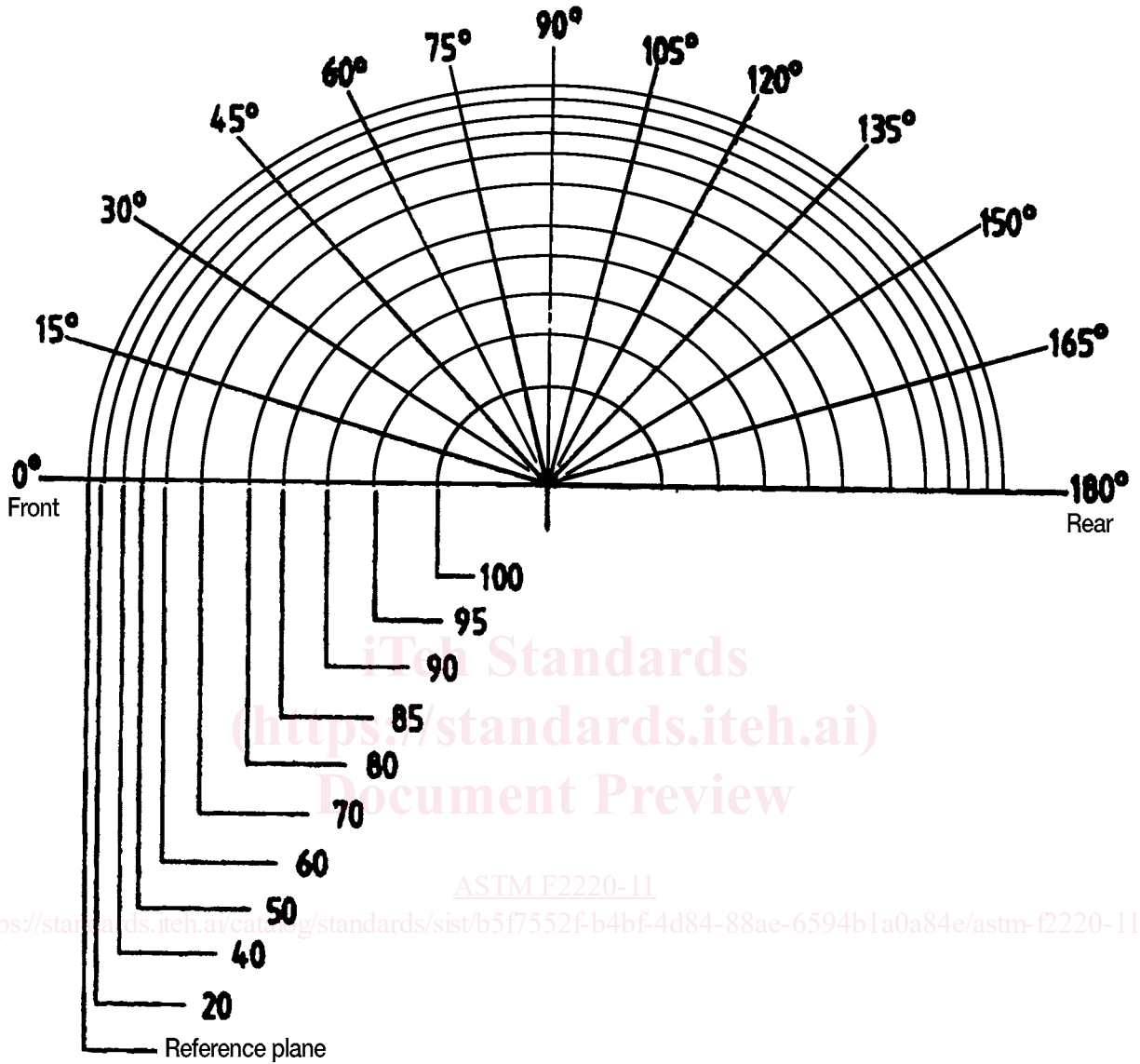

FIG. A1.2 Horizontal Half-Sections at Datum Levels

TABLE A1.1 Polar Coordinates of Horizontal Half-Sections for Size A Headform

Angle	0° Front	15°	30°	45°	60°	75°	90°	105°	120°	135°	150°	165°	180° Back
Height above reference plane (mm)	Radius (mm)												
0.0	88.0	86.5	83.0	75.5	70.0	67.0	66.5	69.5	73.5	78.5	84.0	87.0	88.0
20.0	85.5	84.5	82.5	75.5	70.0	67.0	66.5	69.5	73.5	78.5	84.0	87.0	87.0
40.0	80.0	79.5	79.0	72.0	67.5	65.0	64.5	67.0	71.0	76.0	80.5	82.0	81.5
50.0	75.0	75.0	74.5	68.5	63.5	61.0	60.5	63.5	67.0	72.0	76.0	77.0	77.0
60.0	68.0	68.0	67.5	62.5	57.5	55.5	55.0	58.0	61.5	66.0	70.0	70.0	70.5
70.0	56.0	56.0	56.5	53.0	49.5	47.0	47.0	49.0	53.0	57.0	61.5	61.0	61.0
80.0	37.0	37.5	37.0	36.5	35.5	34.0	34.0	36.0	39.5	44.5	49.0	49.0	48.5
85.0	23.0	24.0	23.0	22.0	22.0	23.0	24.0	24.5	29.5	33.5	36.0	36.5	37.0

Dimension H: 89.7 mm, Depth to Basic Plane: -24.0 mm.

TABLE A1.2 Polar Coordinates of Horizontal Half-Sections for Size C Headform

Angle	0° Front	15°	30°	45°	60°	75°	90°	105°	120°	135°	150°	165°	180° Back
Height above reference plane (mm)	Radius (mm)												
0.0	91.5	89.5	86.0	79.0	72.5	70.0	69.5	72.5	77.0	82.0	87.5	90.5	91.5
20.0	90.0	88.0	85.5	79.0	72.5	70.0	69.5	72.5	77.0	82.0	87.0	90.0	90.5
40.0	84.5	83.0	82.0	76.0	70.0	68.0	68.0	70.5	74.5	79.5	83.5	85.5	86.5
50.0	77.0	77.0	76.0	70.0	65.5	63.0	62.5	65.0	68.5	73.5	77.5	78.5	78.5
60.0	69.5	70.0	70.0	64.0	59.0	57.0	57.5	59.5	62.5	67.5	72.0	72.0	72.0
70.0	59.5	58.5	59.0	54.0	50.0	48.0	48.0	50.5	54.0	59.0	63.5	64.0	63.5
80.0	41.5	42.0	42.0	39.0	37.5	37.0	37.0	39.0	42.0	47.0	51.5	51.5	51.0
85.0	28.0	28.5	29.0	28.0	26.5	27.0	27.5	29.0	32.5	37.0	41.5	41.0	41.5
90.0	7.0	6.5	7.0	7.5	8.0	9.5	11.5	13.5	17.0	19.5	23.0	22.5	21.0

Dimension H: 91.2 mm, Depth to Basic Plane: -25.0 mm.

TABLE A1.23 Polar Coordinates of Horizontal Half-Sections for Size E Headform

Angle	0° Front	15°	30°	45°	60°	75°	90°	105°	120°	135°	150°	165°	180° Back
Height above reference plane (mm)	Radius (mm)												
0.0	94.5	93.0	90.0	82.0	76.5	73.5	79.0	76.0	80.0	85.0	91.0	94.0	94.5
20.0	92.5	91.5	89.0	82.0	76.5	73.5	79.0	76.0	80.0	85.0	90.5	93.5	94.0
40.0	87.0	87.5	85.0	79.5	74.0	71.0	71.5	74.0	77.5	82.5	88.0	89.0	89.0
50.0	82.5	83.0	81.0	76.0	71.0	68.0	68.0	70.5	74.0	79.5	83.5	84.5	84.5
60.0	76.5	76.5	75.5	71.0	66.5	63.5	63.5	66.0	69.5	74.0	78.5	79.0	79.0
70.0	66.5	66.5	66.5	63.0	59.0	56.5	56.5	58.5	62.0	66.5	70.5	71.0	71.0
80.0	52.0	52.0	52.0	50.0	47.5	46.0	46.5	48.0	51.0	56.0	59.5	60.0	60.0
85.0	41.5	42.5	41.5	40.5	39.5	39.0	39.5	41.0	44.0	48.0	51.5	58.0	52.0
90.0	28.0	28.0	28.5	28.5	28.5	29.0	30.0	31.0	34.0	37.5	41.5	42.0	42.0
95.0	10.0	10.0	10.0	10.0	10.0	10.5	11.0	12.0	13.5	15.0	16.0	16.0	16.0

Dimension H: 96.0 mm, Depth to Basic Plane: -26.0 mm.