



SLOVENSKI STANDARD
SIST ISO 24496:2025

01-marec-2025

Pisarniško pohištvo - Pisarniški stoli - Metode za določanje mer

Office furniture - Office chairs - Methods for the determination of dimensions

Mobilier de bureau - Sièges de travail pour bureau - Méthodes pour déterminer les dimensions

Ta slovenski standard je istoveten z: **ISO 24496:2021**

ICS:

97.140

Pohištvo

Furniture

SIST ISO 24496:2025

en,fr,de

INTERNATIONAL STANDARD

**ISO
24496**

Second edition
2021-02

Office furniture — Office chairs — Methods for the determination of dimensions

*Mobilier de bureau — Sièges de travail pour bureau — Méthodes
pour déterminer les dimensions*

iTeh Standards
(<https://standards.itih.ai>)
Document Preview

[SIST ISO 24496:2025](https://standards.itih.ai/catalog/standards/sist/c531c0f1-f95f-4b66-81d9-d2ef3c904ae0/sist-iso-24496-2025)

<https://standards.itih.ai/catalog/standards/sist/c531c0f1-f95f-4b66-81d9-d2ef3c904ae0/sist-iso-24496-2025>



Reference number
ISO 24496:2021(E)

© ISO 2021

ISO 24496:2021(E)

iTeh Standards
(<https://standards.iteh.ai>)
Document Preview

[SIST ISO 24496:2025](https://standards.iteh.ai/catalog/standards/sist/c531c0f1-f95f-4b66-81d9-d2ef3c904ae0/sist-iso-24496-2025)

<https://standards.iteh.ai/catalog/standards/sist/c531c0f1-f95f-4b66-81d9-d2ef3c904ae0/sist-iso-24496-2025>



COPYRIGHT PROTECTED DOCUMENT

© ISO 2021

All rights reserved. Unless otherwise specified, or required in the context of its implementation, no part of this publication may be reproduced or utilized otherwise in any form or by any means, electronic or mechanical, including photocopying, or posting on the internet or an intranet, without prior written permission. Permission can be requested from either ISO at the address below or ISO's member body in the country of the requester.

ISO copyright office
CP 401 • Ch. de Blandonnet 8
CH-1214 Vernier, Geneva
Phone: +41 22 749 01 11
Email: copyright@iso.org
Website: www.iso.org

Published in Switzerland

Contents

	Page
Foreword	iv
Introduction	v
1 Scope	1
2 Normative references	1
3 Terms and definitions	1
4 General measurement conditions	22
4.1 General.....	22
4.2 Preliminary preparation.....	22
4.3 Tolerances.....	22
4.4 Measurement uncertainty.....	23
4.5 Angle — Origin and sign convention.....	23
5 Test equipment	24
6 Measurement methods and procedures	26
6.1 General.....	26
6.2 Chair set-up and placement of CMD.....	26
6.2.1 Chair set-up.....	26
6.2.2 Initial placement of CMD on chair.....	27
6.2.3 Final placement of CMD on chair.....	29
6.3 Measuring procedures.....	29
6.3.1 Initial chair measurements.....	29
6.3.2 Measurements with the chair components adjusted to their minimum positions.....	39
6.3.3 Measurements with the chair components in their maximum positions.....	44
6.3.4 Measurements without the CMD in the chair.....	44
7 Test report	47
Annex A (normative) Drawings and specifications, PDF files for CMD with 18 stacked segment lumbar support measurement method	48
Annex B (informative) Anthropometric equivalents of terms and definitions	52
Annex C (informative) Rationale	59
Bibliography	62

ISO 24496:2021(E)

Foreword

ISO (the International Organization for Standardization) is a worldwide federation of national standards bodies (ISO member bodies). The work of preparing International Standards is normally carried out through ISO technical committees. Each member body interested in a subject for which a technical committee has been established has the right to be represented on that committee. International organizations, governmental and non-governmental, in liaison with ISO, also take part in the work. ISO collaborates closely with the International Electrotechnical Commission (IEC) on all matters of electrotechnical standardization.

The procedures used to develop this document and those intended for its further maintenance are described in the ISO/IEC Directives, Part 1. In particular, the different approval criteria needed for the different types of ISO documents should be noted. This document was drafted in accordance with the editorial rules of the ISO/IEC Directives, Part 2 (see www.iso.org/directives).

Attention is drawn to the possibility that some of the elements of this document may be the subject of patent rights. ISO shall not be held responsible for identifying any or all such patent rights. Details of any patent rights identified during the development of the document will be in the Introduction and/or on the ISO list of patent declarations received (see www.iso.org/patents).

Any trade name used in this document is information given for the convenience of users and does not constitute an endorsement.

For an explanation of the voluntary nature of standards, the meaning of ISO specific terms and expressions related to conformity assessment, as well as information about ISO's adherence to the World Trade Organization (WTO) principles in the Technical Barriers to Trade (TBT) see www.iso.org/iso/foreword.html.

This document was prepared by Technical Committee ISO/TC 136 *Furniture*.

Any feedback or questions on this document should be directed to the user's national standards body. A complete listing of these bodies can be found at www.iso.org/members.html.

This second edition cancels and replaces the first edition (ISO 24496:2017), which has been technically revised. The main changes compared to the previous edition are as follows:

- term [3.2](#) "Angle – Origin and sign convention" has been turned into a new [Clause 4.5](#); numbering of terms and definitions was adapted accordingly, as well as numbering of [Figures 2](#) to [27](#);
- symbols used in [Figures 3](#) to [7](#), [9](#), [10](#), [13](#) to [15](#), [18](#) to [22](#), [24](#) to [26](#), [52](#) to [55](#), and [61](#) were revised;
- the definition of backrest width has been revised; [3.10](#), [Figure 9](#) and 6.3.4.4 have been changed accordingly;
- in [6.3.1.1](#), a specification of the most prominent point has been given and the tolerances adapted;
- specification of the measurement has been described in [6.3.2.2](#);
- values given in [3.3](#) and [Figure 3](#), 6.3.4.8 and [Figure 61](#) have been corrected;
- [Figure 56](#) has been revised;
- [Annex C](#) has been fully revised;
- Bibliography has been updated.

Introduction

A new office chair measurement method and a new chair measuring device (CMD) was developed in order to end the use of numerous sometimes conflicting chair measurement methods and CMDs with their particular weaknesses used in different countries around the world and make it easier to compare office chairs. The measurement methods and designs of CMDs considered during the development of this standard were from BIFMA CMD-1; BS 5940-1; DIN 4551; EN 1335-1; Sedometer according to 2 PFG 947; NF D 61040; SS 83 91 40 and UNI 7498.

The measurement method and the CMD developed in this standard used the strengths of the above mentioned measurement methods and CMDs.

The list of chair dimensions that can be measured using this standard are the dimensions measured in the standards listed above as well as additional ones which are based on the ergonomic factors listed in ISO 9241-5.

The test methods in this document are based on the manner in which anthropometric dimensions are measured.

Therefore, in order to be able to relate the dimensions of office seating to the anthropometric dimensions, a theoretical reference seating posture has been adopted. However, this posture does not automatically correspond to the ideal or optimum seating posture.

The reference seating posture is as follows:

- the sole of the foot placed on the floor;
- the foot forms an angle of approximately 90° with the lower leg;
- the lower leg is approximately vertical;
- the lower leg forms an angle of approximately 90° with the thigh;
- the thigh is almost horizontal;
- the thigh forms an angle of approximately 90° with the trunk;
- the trunk is erect.

Further information on the anthropometric dimensions can be found in ISO 7250-1, the ISO 20685 series and ISO 14738.

This document describes measurement methods. It can be used in conjunction with other relevant documents giving dimensional requirements.

For the rationale for the provisions contained in this document, see [Annex C](#).

Office furniture — Office chairs — Methods for the determination of dimensions

1 Scope

This document specifies methods for the determination of the dimensions of office chairs.

This document does not contain dimensional specifications or requirements.

2 Normative references

There are no normative references in this document.

3 Terms and definitions

For the purposes of this document, the following terms and definitions apply.

ISO and IEC maintain terminological databases for use in standardization at the following addresses:

- ISO Online browsing platform: available at <https://www.iso.org/obp>
- IEC Electropedia: available at <http://www.electropedia.org/>

NOTE For the anthropometric equivalents of the terms and definitions, see [Annex B](#).

3.1

angle between backrest and seat

γ

angle between the loaded backrest and the loaded seat

Note 1 to entry: See [Figure 1](#).

ISO 24496:2021(E)

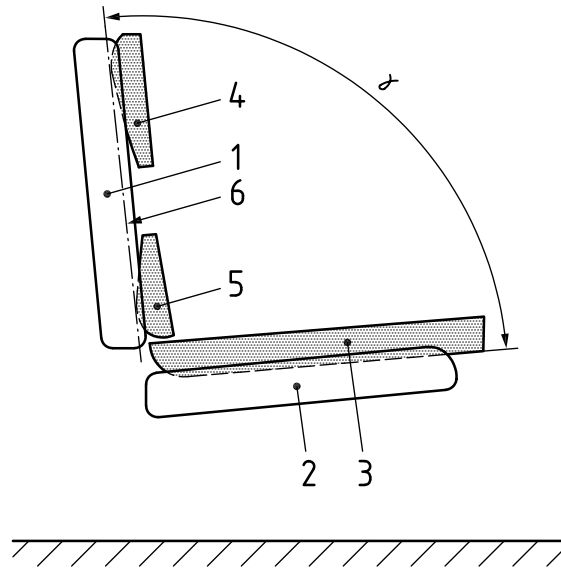
**Key**

- 1 backrest
- 2 seat
- 3 chair measurement device (CMD) buttocks pad
- 4 CMD thoracic pad
- 5 CMD pelvic pad
- 6 backrest line
- γ angle between backrest and seat

Figure 1 — Angle between backrest and seat

3.2 armrest height [sist-iso-24496-2025](https://standards.iteh.ai/catalog/standards/sist/c531c0f1-f95f-4b66-81d9-d2ef3c904ae0/sist-iso-24496-2025)
 distance from the top surface of the armrest to the bottom of the loaded CMD buttocks pad parallel to the backrest line at a distance of 214 mm from the backrest line

Note 1 to entry: See [Figure 2](#).

Dimensions in millimetres

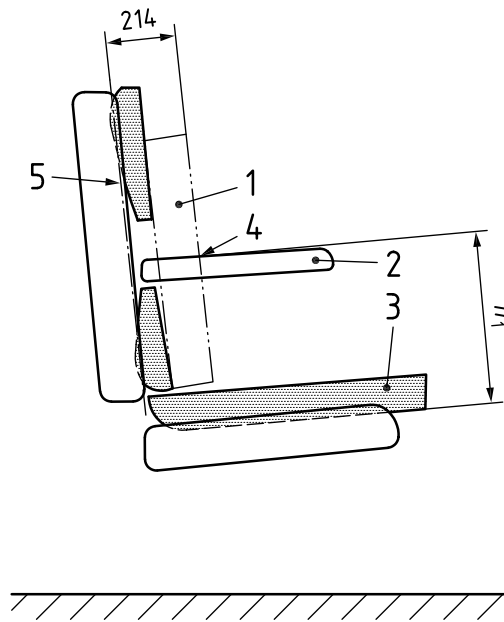
**Key**

- 1 CMD vertical member
- 2 armrest
- 3 CMD buttocks pad
- 4 intersection of projection of vertical member front face and armrest
- 5 backrest line
- h_1 armrest height

iTeh Standards
<https://standards.itih.ai>
 Document Preview

Figure 2 — Armrest height

SIST ISO 24496:2025

<https://standards.itih.ai/catalog/standards/sist/c531c0f1-f95f-4b66-81d9-d2ef3c904ae0/sist-iso-24496-2025>

3.3**armrest length**

distance along the armrest within an envelope down from the top of the armrest that is 20 mm deep

Note 1 to entry: See [Figure 3](#).

Dimensions in millimetres

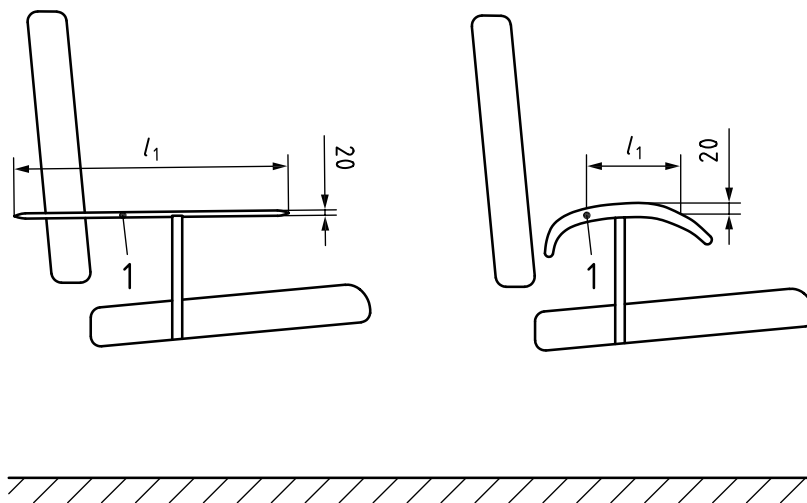
**Key**

- 1 armrest
 l_1 armrest length

Figure 3 — Armrest length**3.4****distance between armrests**

horizontal distance between armrests from the rear of the seat surface width zone forward to the front edge of the seat within the measurement zone 5 mm down from the top of the armrest

Note 1 to entry: See [Figure 4](#), [Figure 6](#) and [seat surface width zone \(3.27\)](#).

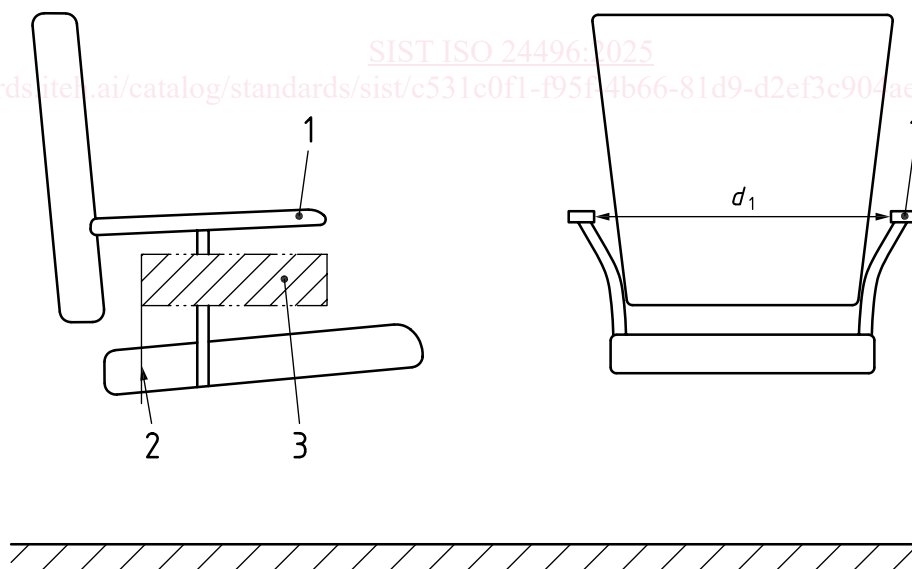
**Key**

- 1 armrest
 2 rear of seat width zone
 3 armrest pad measurement zone
 d_1 distance between armrests

Figure 4 — Distance between armrests

3.5

front of armrest position

perpendicular distance from the backrest line to the front of the armrest that is in the measurement zone 120 mm and greater above the top surface of the loaded CMD buttocks pad

Note 1 to entry: See [Figure 5](#).

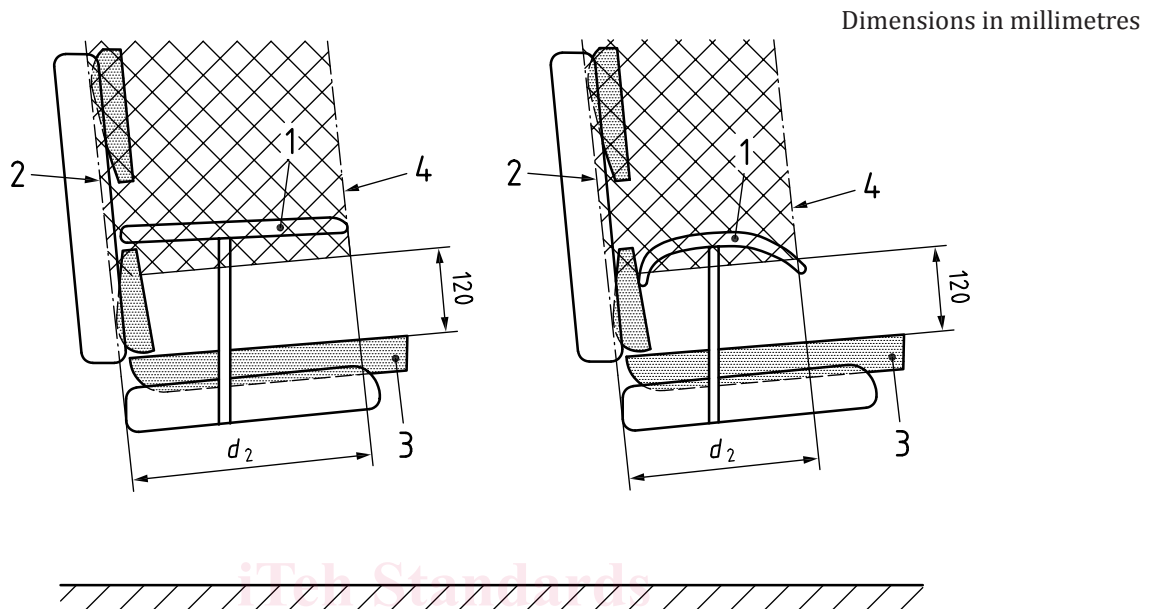

Key

- 1 armrest
- 2 backrest line
- 3 CMD buttocks pad
- 4 measurement zone
- d_2 front of armrest position

SIST ISO 24496:2025
<https://standards.iteh.ai/catalog/standards/sist/c531c0f1-f95f-4b66-81d9-d2ef3c904ae0/sist-iso-24496-2025>

Figure 5 — Front of armrest position

3.6

armrest width

horizontal distance across the armrest within the measurement zone 5 mm down from the top of the armrest

Note 1 to entry: See [Figure 6](#).

ISO 24496:2021(E)

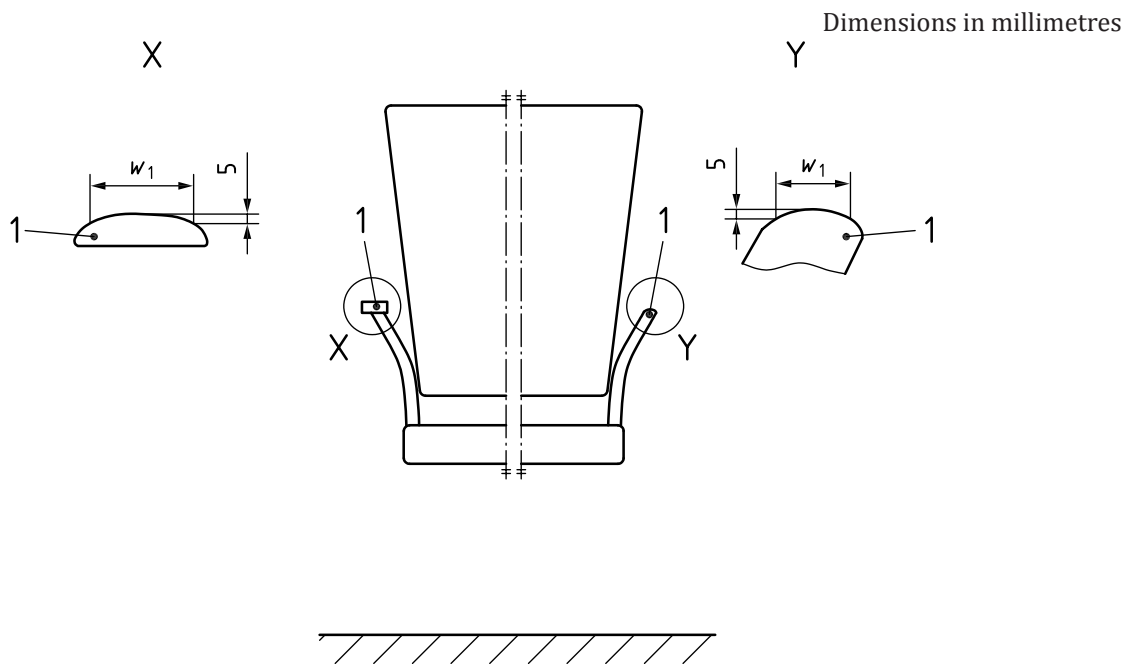
**Key**

1 armrest

 w_1 armrest width**Figure 6 — Armrest width****3.7
backrest to seat movement ratio**

ratio of change of the backrest angle relative to the change of angle of the seat that occurs when a seat and backrest move concurrently

SIST ISO 24496:2025

Note 1 to entry: Does not apply to chairs with seat and/or back angles that only move independently.

**3.8
backrest angle to vertical** β

angle between vertical and the loaded backrest

Note 1 to entry: See [Figure 7](#).