**Electrically propelled road vehicles —
Test specification for electric
propulsion components —**

**Part 4:
Performance testing of the DC/DC
converter**

iTeh STANDARD PREVIEW

(standards.iteh.ai)
*Véhicules à propulsion électrique — Spécification d'essai pour les
composants de propulsion électrique —*

Partie 4: Essais de performance pour le convertisseur DC/DC

<https://standards.iteh.ai/catalog/standards/sist/6a817116-cd56-44b7-aa0f-287973f02499/iso-prf-21782-4>

PROOF / ÉPREUVE



iTeh STANDARD PREVIEW
(standards.iteh.ai)

[ISO/PRF 21782-4](https://standards.iteh.ai/catalog/standards/sist/6a817116-cd56-44b7-aa0f-287973f02499/iso-prf-21782-4)

<https://standards.iteh.ai/catalog/standards/sist/6a817116-cd56-44b7-aa0f-287973f02499/iso-prf-21782-4>



COPYRIGHT PROTECTED DOCUMENT

© ISO 2021

All rights reserved. Unless otherwise specified, or required in the context of its implementation, no part of this publication may be reproduced or utilized otherwise in any form or by any means, electronic or mechanical, including photocopying, or posting on the internet or an intranet, without prior written permission. Permission can be requested from either ISO at the address below or ISO's member body in the country of the requester.

ISO copyright office
CP 401 • Ch. de Blandonnet 8
CH-1214 Vernier, Geneva
Phone: +41 22 749 01 11
Email: copyright@iso.org
Website: www.iso.org

Published in Switzerland

Contents

	Page
Foreword	iv
1 Scope	1
2 Normative references	1
3 Terms and definitions	1
4 Symbols and abbreviated terms	1
5 Tests	1
5.1 Measurement of loss and efficiency	1
5.1.1 General	1
5.1.2 Test diagram	1
5.1.3 Test conditions	2
5.1.4 Test procedure	3
5.2 Temperature rise test	3
5.2.1 General	3
5.2.2 Test diagram	3
5.2.3 Test conditions	4
5.2.4 Test procedure	5
6 Test report	5
Annex A (informative) Test report	6
Annex B (normative) Operating points	8

iTech STANDARD PREVIEW
(standards.itech.ai)

[ISO/PRF 21782-4](https://standards.itech.ai/catalog/standards/sist/6a817116-cd56-44b7-aa0f-287973f02499/iso-prf-21782-4)

<https://standards.itech.ai/catalog/standards/sist/6a817116-cd56-44b7-aa0f-287973f02499/iso-prf-21782-4>

Foreword

ISO (the International Organization for Standardization) is a worldwide federation of national standards bodies (ISO member bodies). The work of preparing International Standards is normally carried out through ISO technical committees. Each member body interested in a subject for which a technical committee has been established has the right to be represented on that committee. International organizations, governmental and non-governmental, in liaison with ISO, also take part in the work. ISO collaborates closely with the International Electrotechnical Commission (IEC) on all matters of electrotechnical standardization.

The procedures used to develop this document and those intended for its further maintenance are described in the ISO/IEC Directives, Part 1. In particular, the different approval criteria needed for the different types of ISO documents should be noted. This document was drafted in accordance with the editorial rules of the ISO/IEC Directives, Part 2 (see www.iso.org/directives).

Attention is drawn to the possibility that some of the elements of this document may be the subject of patent rights. ISO shall not be held responsible for identifying any or all such patent rights. Details of any patent rights identified during the development of the document will be in the Introduction and/or on the ISO list of patent declarations received (see www.iso.org/patents).

Any trade name used in this document is information given for the convenience of users and does not constitute an endorsement.

For an explanation of the voluntary nature of standards, the meaning of ISO specific terms and expressions related to conformity assessment, as well as information about ISO's adherence to the World Trade Organization (WTO) principles in the Technical Barriers to Trade (TBT), see www.iso.org/iso/foreword.html.

This document was prepared by Technical Committee ISO/TC 22, *Road vehicles*, Subcommittee SC 37, *Electrically propelled vehicles*.

A list of all parts in the ISO 21782 series can be found on the ISO website.

Any feedback or questions on this document should be directed to the user's national standards body. A complete listing of these bodies can be found at www.iso.org/members.html.

Electrically propelled road vehicles — Test specification for electric propulsion components —

Part 4: Performance testing of the DC/DC converter

1 Scope

This document specifies performance tests and each evaluation for the DC/DC converter in the voltage class B electric propulsion system of electrically propelled road vehicles.

2 Normative references

The following documents are referred to in the text in such a way that some or all of their content constitutes requirements of this document. For dated references, only the edition cited applies. For undated references, the latest edition of the referenced document (including any amendments) applies.

ISO 21782-1:2019, *Electrically propelled road vehicles — Test specification for electric propulsion components — Part 1: General test conditions and definitions*

ISO 21498-1, *Electrically propelled road vehicles — Specification of voltage sub-classes for voltage class B*

3 Terms and definitions

For the purposes of this document, the terms and definitions given in ISO 21782-1 apply.

ISO and IEC maintain terminological databases for use in standardization at the following addresses:

- ISO Online browsing platform: available at <https://www.iso.org/obp>
- IEC Electropedia: available at <http://www.electropedia.org/>

4 Symbols and abbreviated terms

For the purposes of this document, the symbols and abbreviated terms given in ISO 21782-1 apply.

5 Tests

5.1 Measurement of loss and efficiency

5.1.1 General

The purpose of this test is to operate the DC/DC converter under the specified conditions and to measure the loss and the efficiency of the DC/DC converter in order to ensure the performance is as designed.

5.1.2 Test diagram

The test diagram is shown in [Figure 1](#).

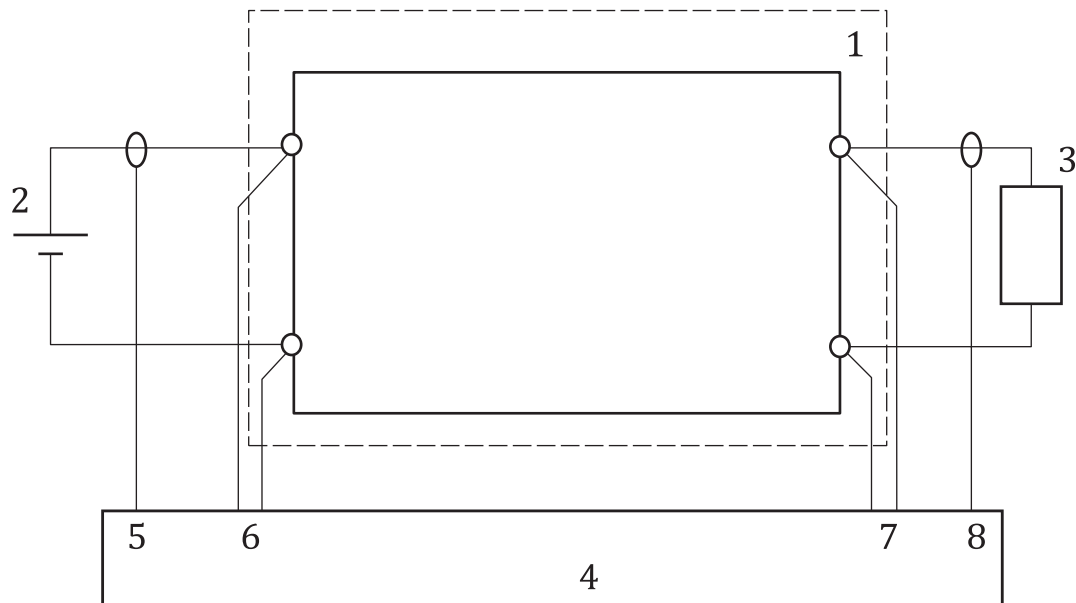

Key

- 1 DUT
- 2 DC power supply
- 3 load
- 4 power meter
- 5 DC/DC converter input current (in A)
- 6 DC/DC converter input voltage (in V)
- 7 DC/DC converter output voltage (in V)
- 8 DC/DC converter output current (in A)

iTeh STANDARD PREVIEW
(standards.iteh.ai)

<https://standards.iteh.ai/catalog/standards/sist/6a817116-cd56-44b7-aa0f-287973f02499/iso-prf-21782-4>
ISO/PRF 21782-4

Figure 1 — Diagram for loss and efficiency test of the DC/DC converter

5.1.3 Test conditions

Test conditions are shown in [Table 1](#).

Table 1 — Conditions for loss and efficiency test of the DC/DC converter

Test conditions	Value	Remark
DC/DC converter input voltage	<ul style="list-style-type: none"> — Maximum voltage for unlimited operating capability (ISO 21498-1) — Minimum voltage for unlimited operating capability (ISO 21498-1) — Rated voltage as defined in ISO 21782-1:2019, 3.22. 	For DC/DC converter input voltage tolerance, see ISO 21782-1:2019, 5.3.
Operating points	Test points as defined in Figure B.1. <ul style="list-style-type: none"> — “p₁” to “p₁₈” 	
Ambient conditions	Room temperature (RT) and humidity as defined in ISO 21782-1:2019, 5.4.	

Table 1 (continued)

Test conditions		Value	Remark
Coolant temperature	Liquid	Maximum temperature for unlimited operating capability	— Ethylene glycol and propylene glycol as examples of coolant — If technically feasible, the tests shall be performed at coolant temperature of 65 °C. Otherwise the deviation shall be documented in the test report.
	Air	Maximum temperature for unlimited operating capability	
Coolant flow rate	Liquid	Minimum flow rate for unlimited operating capability	
	Air	Minimum flow rate for unlimited operating capability	
Operating time	"p ₁ " to "P ₁₅ "	1 800 s	
	"p ₁₆ " to "P ₁₈ "	2 s or 10 s (Optional 30 s, 60 s)	

5.1.4 Test procedure

The test shall be carried out as follows.

- a) The test DC/DC converter shall be operated at specified operating points for the operating time defined in Table 1. Averages of the input power and output power during the last 1 s of the operating time shall be recorded.
- b) The loss and efficiency shall be calculated by the following formulae.

$$P_{dl} = P_{di} - P_{do} \quad (1)$$

$$\eta_d = \frac{P_{do}}{P_{di}} \times 100 \quad (2)$$

where

P_{dl} is loss of DC/DC converter (in W);

P_{do} is DC/DC converter output power (in W);

P_{di} is DC/DC converter input power (in W);

η_d is efficiency of DC/DC converter (in %).

5.2 Temperature rise test

5.2.1 General

This test is to operate the DC/DC converter under the specified conditions and to measure the temperature rise in the DC/DC converter in order to ensure the thermal performance is as designed.

5.2.2 Test diagram

The test diagram is shown in Figure 2.

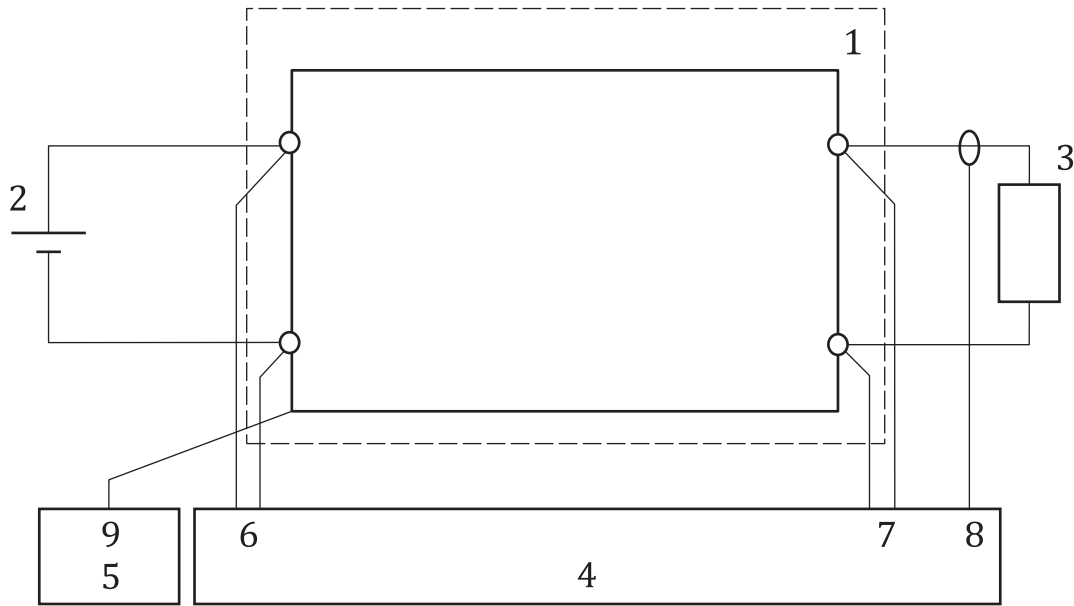

Key

- 1 DUT
- 2 DC power supply
- 3 load
- 4 power meter
- 5 thermometer
- 6 DC/DC converter input voltage (in V)
- 7 DC/DC converter output voltage (in V)
- 8 DC/DC converter output current (in A)
- 9 measurement points temperatures (in °C)

iTeh STANDARD PREVIEW
(standards.iteh.ai)

ISO/PRF 21782-4
<https://standards.iteh.ai/catalog/standards/sist/6a817116-cd56-44b7-aa0f-287973f02499/iso-prf-21782-4>

Figure 2 — Diagram for temperature rise test of the DC/DC converter

5.2.3 Test conditions

The test conditions are shown in [Table 2](#).

Table 2 — Conditions for temperature rise test of the DC/DC converter

Test conditions	Value	Remark
DC/DC converter input voltage	Maximum and minimum voltage for unlimited operating capability (ISO 21498-1) Rated voltage as defined in ISO 21782-1:2019, 3.22	For DC/DC converter input voltage tolerance, see ISO 21782-1:2019, 5.3
DC/DC converter output voltage	Design value	
DC/DC converter output current	The points as defined in B.1 — "p ₅ ", "p ₁₆ "	
Ambient conditions	RT and humidity as defined in ISO 21782-1:2019, 5.4	

Table 2 (continued)

Test conditions		Value	Remark
Coolant temperature	Liquid	Maximum temperature for unlimited operating capability	— Ethylene glycol and propylene glycol as examples of coolant — If technically feasible the tests shall be performed at coolant temperature of 65 °C. Otherwise the deviation shall be documented in the test report
	Air	Maximum temperature for unlimited operating capability	
Coolant flow rate	Liquid	Minimum flow rate for unlimited operating capability	
	Air	Minimum flow rate for unlimited operating capability	
Operating time		— The operating point "p ₅ ": 1 800 s — The operating point "p ₁₆ ": 2 s or 10 s (optional 30 s, 60 s)	

5.2.4 Test procedure

- a) The DC/DC converter shall be operated by the $I_{t=t_0}$, and the temperature of each part of the DC/DC converter shall be recorded after specified time (t_0) passes.
- b) The temperature shall be measured by the thermometer method. The temperature measurement points are shown below:
- electrode part of power semiconductor or specified point of the cooling components closely connected to these parts;
 - inlet and outlet of coolant (in case of liquid cooling);
 - inlet and outlet of air (in case of air cooling).

Some points may be added by the agreement between the supplier and customer.

6 Test report

Each test shall be reported with a test report, containing information on test conditions and results. Examples for test reports on conditions and results are given in [Tables A.1](#) and [A.2](#).

Annex A (informative)

Test report

A.1 Measurement of loss and efficiency

Table A.1 — Loss and efficiency of the DC/DC converter

1 Common conditions				
	Items		Value	Remark
Ambient conditions	Temperature (in °C)			
	Humidity (in %)			
Cooling type			Liquid/Air	
Coolant temperature (in °C)				
Coolant flow rate (in l/min)				
2 Results and individual conditions				
	Items		Value	Remark
Operating point				
Operating time (in s)				
DC/DC converter input current (in A)				
DC/DC converter input voltage (in V)	Target			
	Measured			
Power (in W)				
DC/DC converter output current (in A)	Target			
	Measured			
DC/DC converter output voltage (in V)				
DC/DC converter output power (in W)				
Calculated results	Loss (in W)			
	Efficiency (in %)			

A.2 Temperature rise test

Table A.2 — Temperature rise test of the DC/DC converter

1 Common conditions				
	Items		Value	Remark
Ambient conditions	Temperature (in °C)			
	Humidity (in %)			
Cooling type			Liquid/Air	
Coolant temperature (in °C)				
Coolant flow rate (in l/min)				
2 Results and individual conditions				
	Items		Value	Remark