

---

---

**Industrial trucks — Verification of  
stability —**

**Part 15:  
Counterbalanced trucks with  
articulated steering**

**iTeh STANDARD PREVIEW**  
*Chariots de manutention — Vérification de la stabilité —  
Partie 15: Chariots avec dispositif de direction articulé travaillant en  
porte-a-faux*  
(standards.iteh.ai)

[ISO 22915-15:2020](https://standards.iteh.ai/catalog/standards/sist/7bc297a6-f512-4800-a59a-5e8333b8d281/iso-22915-15-2020)

<https://standards.iteh.ai/catalog/standards/sist/7bc297a6-f512-4800-a59a-5e8333b8d281/iso-22915-15-2020>



**iTeh STANDARD PREVIEW**  
**(standards.iteh.ai)**

ISO 22915-15:2020  
<https://standards.iteh.ai/catalog/standards/sist/7bc297a6-f512-4800-a59a-5e8333b8d281/iso-22915-15-2020>



**COPYRIGHT PROTECTED DOCUMENT**

© ISO 2020

All rights reserved. Unless otherwise specified, or required in the context of its implementation, no part of this publication may be reproduced or utilized otherwise in any form or by any means, electronic or mechanical, including photocopying, or posting on the internet or an intranet, without prior written permission. Permission can be requested from either ISO at the address below or ISO's member body in the country of the requester.

ISO copyright office  
CP 401 • Ch. de Blandonnet 8  
CH-1214 Vernier, Geneva  
Phone: +41 22 749 01 11  
Fax: +41 22 749 09 47  
Email: [copyright@iso.org](mailto:copyright@iso.org)  
Website: [www.iso.org](http://www.iso.org)

Published in Switzerland

# Contents

	Page
Foreword .....	iv
<b>1 Scope .....</b>	<b>1</b>
<b>2 Normative references .....</b>	<b>1</b>
<b>3 Terms and definitions .....</b>	<b>1</b>
<b>4 Test conditions .....</b>	<b>1</b>
4.1 General .....	1
4.2 Position of truck on the tilt table .....	1
4.2.1 Load and rear axles .....	1
4.2.2 Test 1 .....	2
4.2.3 Test 2 .....	2
4.2.4 Test 3, 4 and 5 .....	2
4.3 Datum point positions .....	2
4.4 Lift height for tests simulating travel .....	4
<b>5 Verification of stability .....</b>	<b>4</b>

## iTeh STANDARD PREVIEW (standards.iteh.ai)

[ISO 22915-15:2020](https://standards.iteh.ai/catalog/standards/sist/7bc297a6-f512-4800-a59a-5e8333b8d281/iso-22915-15-2020)

<https://standards.iteh.ai/catalog/standards/sist/7bc297a6-f512-4800-a59a-5e8333b8d281/iso-22915-15-2020>

## Foreword

ISO (the International Organization for Standardization) is a worldwide federation of national standards bodies (ISO member bodies). The work of preparing International Standards is normally carried out through ISO technical committees. Each member body interested in a subject for which a technical committee has been established has the right to be represented on that committee. International organizations, governmental and non-governmental, in liaison with ISO, also take part in the work. ISO collaborates closely with the International Electrotechnical Commission (IEC) on all matters of electrotechnical standardization.

The procedures used to develop this document and those intended for its further maintenance are described in the ISO/IEC Directives, Part 1. In particular, the different approval criteria needed for the different types of ISO documents should be noted. This document was drafted in accordance with the editorial rules of the ISO/IEC Directives, Part 2 (see [www.iso.org/directives](http://www.iso.org/directives)).

Attention is drawn to the possibility that some of the elements of this document may be the subject of patent rights. ISO shall not be held responsible for identifying any or all such patent rights. Details of any patent rights identified during the development of the document will be in the Introduction and/or on the ISO list of patent declarations received (see [www.iso.org/patents](http://www.iso.org/patents)).

Any trade name used in this document is information given for the convenience of users and does not constitute an endorsement.

For an explanation of the voluntary nature of standards, the meaning of ISO specific terms and expressions related to conformity assessment, as well as information about ISO's adherence to the World Trade Organization (WTO) principles in the Technical Barriers to Trade (TBT), see [www.iso.org/iso/foreword.html](http://www.iso.org/iso/foreword.html).

This document was prepared by Technical Committee ISO/TC 110, *Industrial trucks*, Subcommittee SC 2, *Safety of powered industrial trucks*.

This second edition cancels and replaces the first edition (ISO 22915-15:2013), which has been technically revised.

The main change compared to the previous edition is the update of normative references.

A list of all parts in the ISO 22915 series can be found on the ISO website.

Any feedback or questions on this document should be directed to the user's national standards body. A complete listing of these bodies can be found at [www.iso.org/members.html](http://www.iso.org/members.html).

# Industrial trucks — Verification of stability —

## Part 15: Counterbalanced trucks with articulated steering

### 1 Scope

This document specifies the tests for verifying the stability of counterbalanced fork-lift trucks with articulating steering and with mast, equipped with fork arms or load-handling attachments.

It is not applicable to trucks with retractable devices such as a retractable mast or fork.

### 2 Normative references

The following documents are referred to in the text in such a way that some or all of their content constitutes requirements of this document. For dated references, only the edition cited applies. For undated references, the latest edition of the referenced document (including any amendments) applies.

ISO 5053-1, *Industrial trucks — Terminology and classification — Part 1: Types of industrial trucks*

ISO 22915-1, *Industrial trucks — Verification of stability — Part 1: General*

### 3 Terms and definitions

ISO 22915-15:2020

For the purposes of this document, the terms and definitions given in ISO 5053-1 and ISO 22915-1 apply.

ISO and IEC maintain terminological databases for use in standardization at the following addresses:

- ISO Online browsing platform: available at <https://www.iso.org/obp>
- IEC Electropedia: available at <http://www.electropedia.org/>

### 4 Test conditions

#### 4.1 General

See ISO 22915-1.

#### 4.2 Position of truck on the tilt table

##### 4.2.1 Load and rear axles

The load and rear axles are defined by [Figure 1](#).

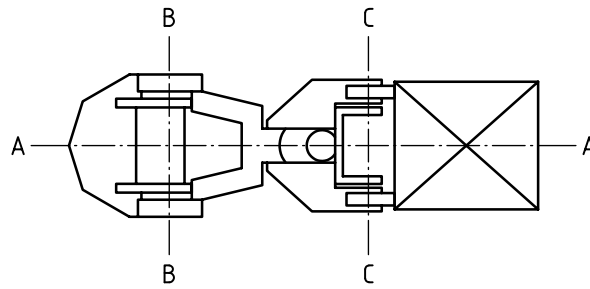

**Key**

- A-A longitudinal centre plane of truck
- B-B rear axle
- C-C load axle

**Figure 1 — Load and rear axles**

**4.2.2 Test 1**

The truck shall be positioned on the tilt table so that the load axle is parallel to the tilt axis, X-Y, of the tilt table, with the steering at maximum articulation (see [Table 1](#)).

**4.2.3 Test 2**

The truck shall be positioned on the tilt table so that the load axle and the rear axle are parallel to X-Y (see [Table 1](#)).



**4.2.4 Test 3, 4 and 5**

ISO 22915-15:2020  
<https://standards.iteh.ai/catalog/standards/sist/7bc297a6-f512-4800-a59a-c333b15116/c72915-15:2020>

The lateral stability tests according to [Table 1](#) shall be conducted on the side of the truck which is the least stable.

The truck shall be positioned on the tilt table at maximum articulation with line M-N parallel to X-Y (see [Table 1](#)).

Point M is defined as the centre point of the area of contact between the tilt table surface and the rear wheel nearest to the tilt axis, X-Y, of the tilt table.

Point N is defined as the centre point of the area of contact between the tilt table surface and the load wheel nearest to the tilt axis, X-Y, of the tilt table.

**4.3 Datum point positions**

Test 1 shall be conducted with the horizontal position of the load datum point, E, unchanged when elevated from its lowered position, as shown in [Figure 2](#).

With the prescribed test load, set the mast vertical and then elevate to approximately 300 mm above the tilt table. With the shank of the front face of the fork arm set vertical, establish point E, as shown in [Figure 2 a](#)), on the fork arms or fork carrier having a fixed relationship to the centre of gravity of the test load. E shall be used to provide a reference datum point, F, on the tilt table. When the mast is elevated, a new point, F1, on the tilt table may occur, as shown in [Figure 2 b](#)). This new point may be returned to the original location of F, as shown in [Figure 2 c](#)), by varying the tilt of the mast within the limits provided by the design of the truck.

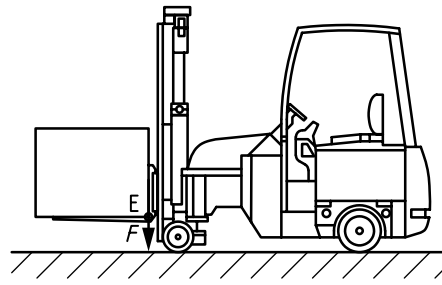

a)

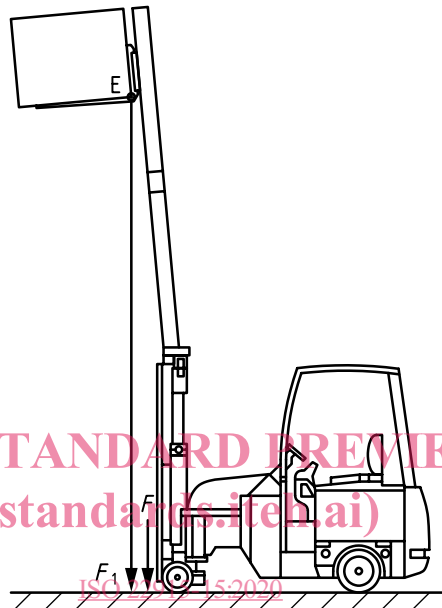

iTeh STANDARD PREVIEW  
(standards.iteh.ai)

ISO 22915-15:2020  
<https://standards.iteh.ai/catalog/standards/sist/7bc297a6-f512-4800-a59a-5e8333b8d281/iso-22915-15-2020>

b)

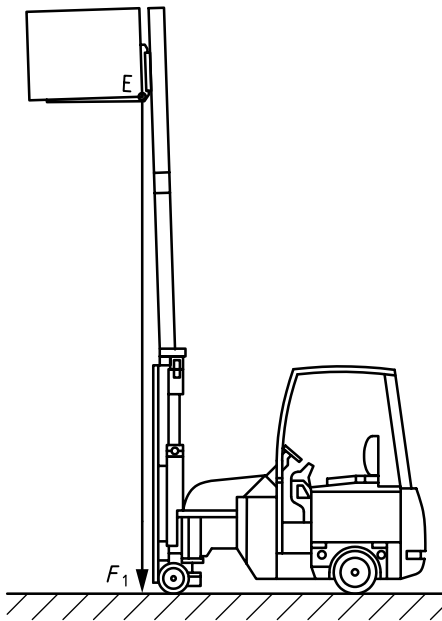

c)

Figure 2 — Datum point positions

#### 4.4 Lift height for tests simulating travel

For tests simulating travel (Tests 2 and 5), the upper face of the fork arms, measured at the heel of the fork arm when fully tilted rearward, shall be positioned 300 mm above the tilt table for trucks with a rated capacity  $\leq 10$  t, and 500 mm for trucks with a rated capacity of  $>10$  t.

### 5 Verification of stability

The stability of a truck shall be verified in accordance with [Table 1](#).

**iTeh STANDARD PREVIEW**  
**(standards.iteh.ai)**

ISO 22915-15:2020

<https://standards.iteh.ai/catalog/standards/sist/7bc297a6-f512-4800-a59a-5e8333b8d281/iso-22915-15-2020>



Table 1 — Verification of stability

Test criteria	Test 1	Test 2	Test 3	Test 4	Test 5
<b>Direction of test</b>					
Longitudinal		x			
Lateral	x		x	x	x
<b>Direction of load handling device</b>					
Load leading		x			
Load trailing			x		
<b>Mode of operation</b>					
Travelling		x			x
Stacking/ retrieving	x		x	x	
<b>Load at load centre</b>					
With	x	x	x		
Without				x	x
<b>Lift height</b>					
Maximum	x		x	x	
Travel		x			x
<b>Position of mast</b>					
Vertical	x				
Full rearward		x	x	x	x
<b>Tilt-table angle for actual capacity</b>					
<5 000 kg	4 %	18 %	6 %	8 %	(15 + 1,4 · v) % <sup>a</sup>
≥5 000 kg	3,5 %			6 %	(15 + 1,4 · v) % <sup>b</sup>

v is the maximum travel speed of the truck (unladen or laden with the actual load), in km/h.

<sup>a</sup> 50 % maximum.

<sup>b</sup> 40 % maximum.

iTeh STANDARD PREVIEW  
(standards.iteh.ai)

ISO 22915-15:2020  
<https://standards.iteh.ai/catalog/standards/sist/712297a6-f512-4800-a59a-5e833388d281/iso-22915-15-2020>