



Designation: D5969 – 11

Standard Test Method for Corrosion-Preventive Properties of Lubricating Greases in Presence of Dilute Synthetic Sea Water Environments¹

This standard is issued under the fixed designation D5969; the number immediately following the designation indicates the year of original adoption or, in the case of revision, the year of last revision. A number in parentheses indicates the year of last reappraisal. A superscript epsilon (ϵ) indicates an editorial change since the last revision or reappraisal.

1. Scope*

1.1 This test method covers the determination of the corrosion-preventive properties of greases using grease-lubricated tapered roller bearings exposed to various concentrations of dilute synthetic sea water stored under wet conditions. It is based on Test Method D1743, which is practiced using a similar procedure and distilled water. The reported result is a pass or fail rating as determined by at least two of three bearings.

1.2 *Apparatus Dimensions*—The values stated in inch-pound units are to be regarded as standard. The values given in parentheses are mathematical conversions to SI units that are provided for information only and are not considered standard.

1.3 *All Other Values*—The values stated in SI units are to be regarded as standard. No other units of measurement are included in this standard.

1.4 *This standard does not purport to address all of the safety concerns, if any, associated with its use. It is the responsibility of the user of this standard to establish appropriate safety and health practices and determine the applicability of regulatory limitations prior to use.*

2. Referenced Documents

2.1 *ASTM Standards:*²

D665 Test Method for Rust-Preventing Characteristics of Inhibited Mineral Oil in the Presence of Water

D1193 Specification for Reagent Water

D1743 Test Method for Determining Corrosion Preventive Properties of Lubricating Greases

3. Terminology

3.1 *Definitions of Terms Specific to This Standard:*

¹ This test method is under the jurisdiction of ASTM Committee D02 on Petroleum Products and Lubricants and is the direct responsibility of Subcommittee D02.G0.06 on Functional Tests - Contamination.

Current edition approved May 1, 2011. Published May 2011. Originally approved in 1996. Last previous edition approved in 2008 as D5969-08. DOI: 10.1520/D5969-11.

² For referenced ASTM standards, visit the ASTM website, www.astm.org, or contact ASTM Customer Service at service@astm.org. For *Annual Book of ASTM Standards* volume information, refer to the standard's Document Summary page on the ASTM website.

3.1.1 *corrosion*—the chemical or electrochemical reaction between a material, usually a metal, and its environment that produces a deterioration of the material and its properties.

3.1.1.1 *Discussion*—In this test method, corrosion is manifested by red rust or black stains on the bearing race. Stains, through which the underlying metal surface is still visible, are not considered corrosion in Test Method D5969 and shall be ignored. **D1743**

4. Summary of Test Method

4.1 New, cleaned, and lubricated bearings are run under a light thrust load for 60 ± 3 s to distribute the lubricant in a pattern that might be found in service. The bearings are exposed to a solution of synthetic sea water at some percentage in distilled water, then stored for $24 \pm \frac{1}{2}$ h at $52 \pm 1^\circ\text{C}$ and 100 % relative humidity. After cleaning, the bearing cups are examined for evidence of corrosion.

5. Significance and Use

5.1 This test method differentiates the relative corrosion-preventive capabilities of lubricating greases under the test conditions.

6. Apparatus

6.1 *Bearings*, Timken bearing cone and roller assembly LM11949 and cup LM11910.³

6.2 *Motor*, 1750-rpm (approximate) speed, $\frac{1}{15}$ hp (min).

6.3 *Bearing Holder*, (see Fig. 1) consists of a 1 ± 0.01 -kg mass, upper and lower plastic collars for the bearing cone (Parts A and B), a metal screw, and a plastic collar for the cup (Part C).

6.4 *Plastic Test Jar*, as shown in Fig. 2.

6.5 *Run-in Stand*,⁴ as shown in Fig. 3.

6.6 *Spindle/Thrust Loading Device*,³ as shown in Fig. 4.

³ Manufactured by the Timken Co., Canton, OH 44706.

⁴ The sole source of supply of the apparatus known to the committee at this time is Falex Corp., 1020 Airpark Drive, Sugar Grove, IL, 60554. If you are aware of alternative suppliers, please provide this information to ASTM International Headquarters. Your comments will receive careful consideration at a meeting of the responsible technical committee,¹ which you may attend.

*A Summary of Changes section appears at the end of this standard

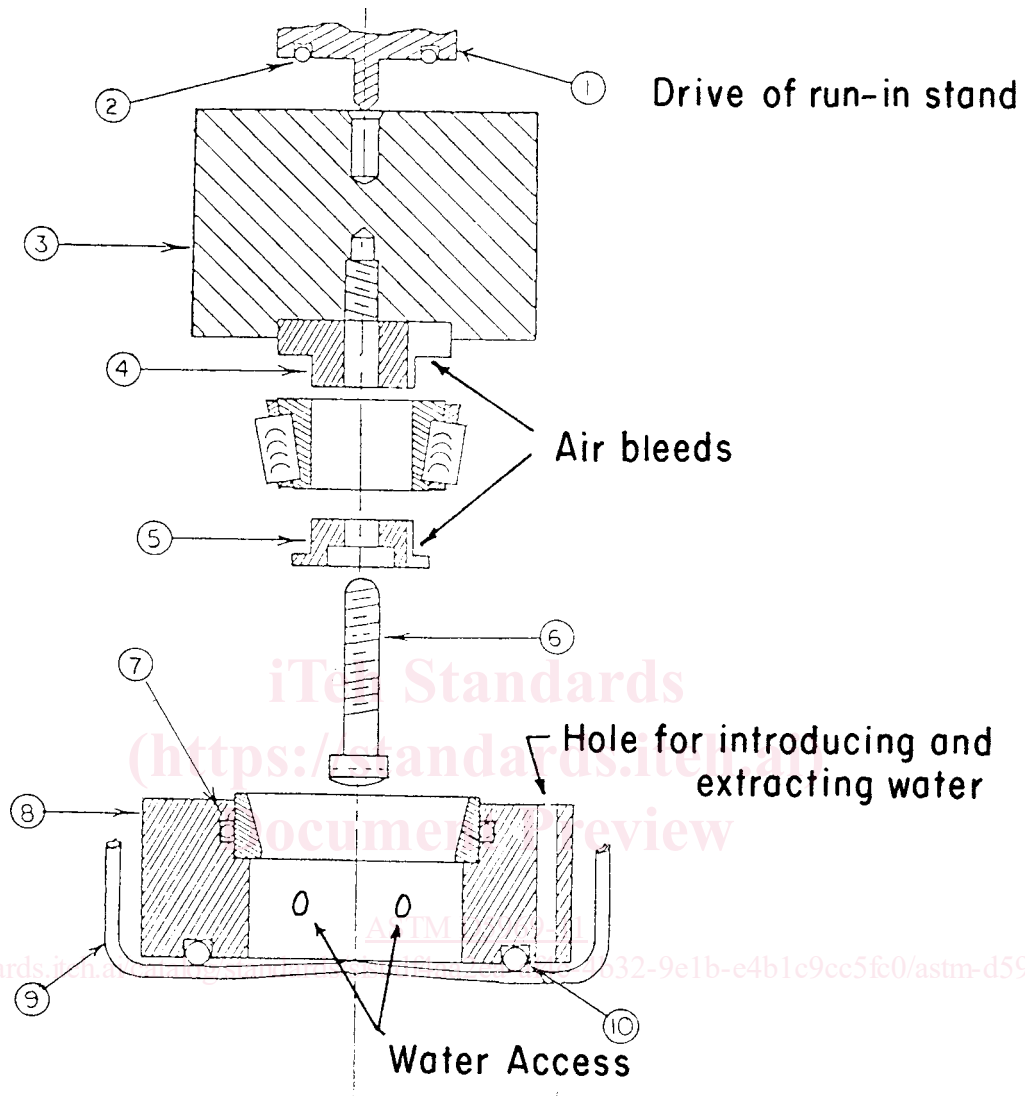

KEY	DESCRIPTION	QUANTITY
1	PISTON	1
2	O RING	1
3	WEIGHT	1
4	UPPER FLANGE	1
5	LOWER FLANGE	1
6	1/4 - 20 x 1-1/4 FILLISTER HD. MACH. SCREW S.S.	1
7	O RING	1
8	BEARING HOLDER	1
9	PLASTIC JAR	1
10	O RING	1

FIG. 1 Test Method D1743 Bearing Holder Assembly

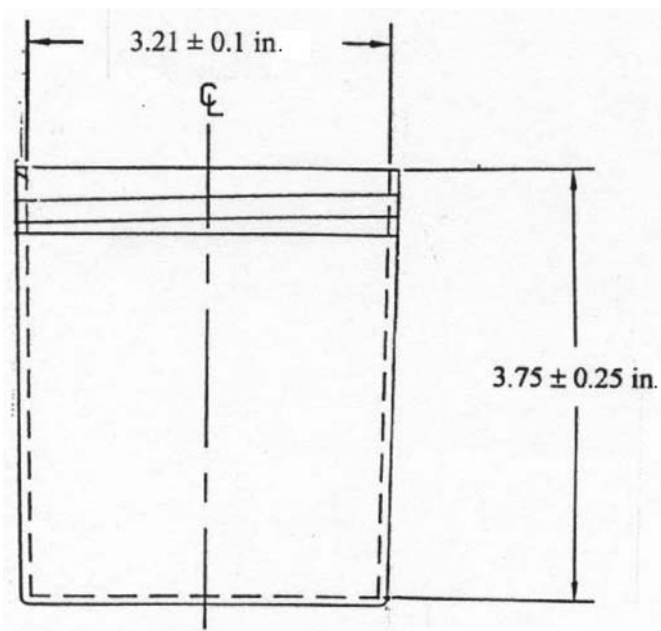

Test Jar Specifications
 Inner Diameter Range: 3.11–3.31 in. (79–84 mm)
 Inner Height Range: 3.5–4.0 in. (89–102 mm)

FIG. 2 Plastic Test Jar

6.7 *Mechanical Grease Packer*, as shown in Fig. 5.

6.8 *Pliers*,⁵ as shown in Fig. 6.

6.9 *Syringe*, of at least 100 ± 5 mL volume and with a needle of at least 16 gauge and a minimum length of 100 mm (4 in.).

6.10 *Timer*, capable of measuring a 60 ± 3 -s interval.

6.11 *Oven*, a laboratory oven, essentially free of vibration, capable of maintaining $52 \pm 1^\circ\text{C}$.

7. Reagents

7.1 *Purity of Reagents*—Reagent grade chemicals shall be used in all tests. Unless otherwise indicated, it is intended that all reagents shall conform to the specifications of the Committee on Analytical Reagents of the American Chemical Society, where such specifications are available.⁶ Other grades may be used, provided that it is first ascertained that the reagent is of sufficiently high purity to permit its use without lessening the accuracy of the determination.

7.2 *Purity of Water*—Unless otherwise indicated, references to water shall be understood to mean reagent water conforming to Specification D1193, Type III.

7.3 *Isopropyl Alcohol*. (**Warning**—Flammable.)

⁵ A Waldes Truarc Plier No. 4, available from Truarc Co., or similar, modified as in Fig. 6.

⁶ *Reagent Chemicals, American Chemical Society Specifications*, American Chemical Society, Washington, DC. For Suggestions on the testing of reagents not listed by the American Chemical Society, see *Annual Standards for Laboratory Chemicals*, BDH Ltd., Poole, Dorset, U.K., and the *United States Pharmacopeia and National Formulary*, U.S. Pharmacopeial Convention, Inc. (USPC), Rockville, MD.

7.4 *Solvent Rinse Solution*, of the following composition by volume:

7.4.1 *Isopropyl Alcohol*, 90 %,

7.4.2 *Distilled Water*, 9 %, and

7.4.3 *Ammonium Hydroxide*, 1 %. (**Warning**—Poison. Causes burns. Vapor extremely irritating. May be fatal if swallowed. Harmful if inhaled.)

7.5 *Mineral Spirits*, reagent grade, minimum purity. (**Warning**—Combustible. Vapor harmful.)

7.6 *Synthetic Sea Water*, prepared as described in Test Method D665. (**Warning**—Poison. May be fatal if swallowed.)

8. Standardization of Thrust Loading Device

8.1 Pack a bearing, and install it into the holder. Place the assembly into a plastic jar as described in 10.1-10.4. Place the jar onto the base of the motor drive spindle and center it under the indexing pin of the drive. Lower the drive until the O-ring just contacts the 1-kg weight. Run the bottom nut of the depth gauge (see Fig. 3) down to the stop. Place a 3-mm spacer on top of this nut. Bring the top nut down to the spacer. While holding the top nut in position, remove the spacer and run the bottom nut up and tighten it against the top nut. When the O-ring is compressed against the 1-kg weight until the adjustment nut hits the stop, there will be a 29-N load added, giving a total load of 39 N on the bearing. (The loads described are provided by the forces of the spring in the thrust loading spindle and the sum of the 1-kg weight and spring, respectively. These loads are approximate. The 1-kg weights should be within 0.010 kg of their stated values. The thrust loading spindle should be calibrated by some suitable method when it is first put into service, recalibrated periodically, and replaced if its spring does not provide sufficient force to spin the test bearings without slippage during the 60-s run to distribute the grease.) Examine the O-ring periodically, and replace it if it shows any cracks or other signs of deterioration.

8.2 The thrust loading device should be standardized before use, once per day if used daily, and again if there is reason to believe that the standardization has changed. The thrust loading device may be standardized using one of the greases to be tested.

9. Preparation of Bearings

9.1 Examine the test bearings carefully and select only bearings that have outer races (cups) and rollers entirely free of corrosion. During the bearing preparation, handle the bearings with tongs or rubber or plastic gloves. Do not touch bearings with the fingers at any time.

9.2 Wash the selected bearings thoroughly in hot (52 to 66°C) mineral spirits, reagent grade (**Warning**—see 7.5) to remove the rust preventive. To ensure complete removal of the rust preventive, subject the bearings to a second wash in fresh hot mineral spirits, reagent grade.

NOTE 1—The washing temperatures specified are considerably above the flash point of the solvent. Accordingly, the washing operation should be carried out in a well-ventilated hood where no flames or other ignition sources are present.