



Designation: E 953 – 88 (Reapproved 1998)

Standard Test Method for Fusibility of Refuse-Derived Fuel (RDF) Ash¹

This standard is issued under the fixed designation E 953; the number immediately following the designation indicates the year of original adoption or, in the case of revision, the year of last revision. A number in parentheses indicates the year of last approval. A superscript epsilon (ϵ) indicates an editorial change since the last revision or reapproval.

1. Scope

1.1 This test method covers the observation of the temperatures at which triangular pyramids (cones) prepared from RDF ash attain and pass through certain stages of fusing and flow when heated at a specific rate in controlled, mildly-reducing, and oxidizing atmospheres.

1.2 The test method is empirical, and strict observance of the requirements and conditions is necessary to obtain reproducible temperatures and enable different laboratories to obtain concordant results.

1.3 The values stated in SI units are to be regarded as the standard. The values given in parentheses are for information only.

1.4 *This standard does not purport to address all of the safety problems, if any, associated with its use. It is the responsibility of the user of this standard to establish appropriate safety and health practices and determine the applicability of regulatory limitations prior to use.* See Section 6 for additional hazard information.

2. Referenced Documents

2.1 ASTM Standards:

- E 180 Practice for Determining the Precision Data of ASTM Methods for Analysis and Testing of Industrial Chemicals²
- E 829 Practice for Preparing Refuse-Derived Fuel (RDF) Laboratory Samples for Analysis³

3. Terminology

3.1 Definitions and Symbols:

3.1.1 The critical temperature points to be observed are as follows, denoting the atmosphere used:

3.2 *initial deformation temperature, IT*—the temperature at which the first rounding of the apex of the cone occurs. Shrinking or warping of the cone is ignored if the tip remains sharp. In Fig. 1, the first cone shown is an unheated one; the second cone, IT, is a typical cone at the initial deformation stage.

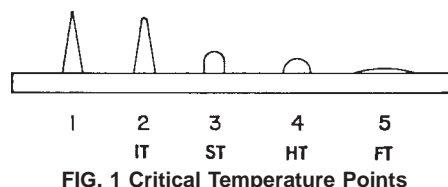

FIG. 1 Critical Temperature Points

3.3 *softening temperature, ST*—the temperature at which the cone has fused down to a spherical lump in which the height is equal to the width at the base as shown by the third cone, ST, in Fig. 1.

3.4 *hemispherical temperature, HT*—the temperature at which the cone has fused down to a hemispherical lump at which point the height is one half the width of the base as shown by the fourth cone, HT, in Fig. 1.

3.5 *fluid temperature, FT*—the temperature at which the fused mass has spread out in a nearly flat layer with a maximum height of 1.6 mm (1/16 in.) as shown in the fifth cone, FT, in Fig. 1.

3.6 forms of refuse-derived fuel (RDF):

- RDF-1—Waste used as a fuel in as-discarded form.
- RDF-2—Waste processed to coarse particle size with or without ferrous metal separation.
- RDF-3—Shredded fuel derived from municipal solid waste (MSN) that has been processed to remove metal, glass, and other inorganics. This material has a particle size such that 95 weight % passes through a 2-in. square mesh screen.
- RDF-4—Combustible waste processed into powder form, 95 weight % passing a 10-mesh screening.
- RDF-5—Combustible waste densified (compressed) into the form of pellets, slugs, cubettes, or briquettes.
- RDF-6—Combustible waste processed into liquid fuel.
- RDF-7—Combustible waste processed into gaseous fuel.

4. Significance and Use

4.1 The standard is available to producers and users of RDF to use in determining the fusibility of ash produced from RDF.

4.2 *Limitations of Ash Fusibility Data*—Ash fusibility data are too often over-interpreted. In practice, types of burning equipment, rate of burning, temperature and thickness of fire bed or ball, distribution of ash forming mineral matter in the RDF, and viscosity of the molten ash may influence ash behavior more than the ash fusibility characteristics determined by the laboratory test. Furthermore, conditions existing during

¹ This test method is under the jurisdiction of ASTM Committee D34 on Waste Management and is the direct responsibility of Subcommittee D34.03 on Treatment. Current edition approved March 25, 1988. Published May 1988. Originally published as E 953 – 83. Last previous edition E 953 – 83.

² *Annual Book of ASTM Standards*, Vol 15.05.

³ *Annual Book of ASTM Standards*, Vol 11.04.

applied combustion of RDF are so complex that they are impossible to duplicate completely in a small-scale laboratory test. Therefore, the test should be considered an empirical one and the data, at best, only qualitative.

5. Apparatus

5.1 *Furnace*—Any gas-fired or electric furnace conforming to the following requirements may be used.

5.1.1 The furnace shall be capable of maintaining a uniform temperature zone in which to heat the ash cones. This zone shall be such that the difference in the melting point of 12.7 mm (1/2 in.) pieces of pure gold wire when mounted in place of the ash cones on the cone support shall be not greater than 11°C (20°F) in a reducing atmosphere test run.

5.1.2 The furnace shall be capable of maintaining the desired atmosphere surrounding the cones during heating. The composition of the atmosphere, reducing or oxidizing, shall be maintained within the limits specified in Section 7. The desired atmosphere in the gas-fired furnace surrounding the cones shall be obtained by regulation of the ratio of gas to air in the combustion mixture. The desired atmosphere in the electric furnace shall be obtained by means of gases introduced into the heating chamber. The muffle shall be gas-impervious, free from cracks, and the closure-plug tight fitting. Since state-of-the-art furnaces vary somewhat in design, the gas supply inlet tube shall be installed per instructions of furnace manufacturer.

5.1.3 The furnace shall be capable of regulation so that the rate of temperature rise shall be $8 \pm 3^\circ\text{C}$ ($15 \pm 5^\circ\text{F}$) per minute.

5.1.4 The furnace shall provide a means of observing the ash cones during the heating. Observation shall be on the same horizontal plane as the cone-support surface.

5.2 *Cone Mold*—A commercially available cone mold as shown in Fig. 2 shall be used. The cone shall be 19 mm (3/4 in.) in height and 6.4 mm (1/4 in.) in width at each side of the base which is an equilateral triangle.

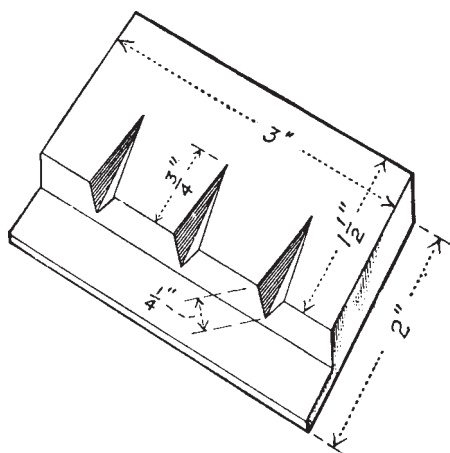

U.S. Customary Units. in.	SI Units, mm
1/4	6.4
3/4	19.1
1 1/2	38.1
2	50.2
3	76.2

FIG. 2 Brass Cone Mold

5.2.1 A steel spatula with a pointed tip, ground off to fit the cone depression in the mold, is suitable for removal of the ash cone.

5.3 *Optical Pyrometer or Thermocouple*, for temperature measurements, conforming to the following requirements:

5.3.1 *Optical Pyrometer*—An optical pyrometer of the disappearing filament type shall be used. The instrument shall have been calibrated to be accurate within 11°C (20°F) up to 1400°C (2550°F) and within 16°C (30°F) from 1400 to 1600°C (2550°F to 2900°F) (Note 2). The pyrometer filament shall be sighted on the cones until the softening point temperature (Fig. 1) has been passed, and then sighted on the cone support. The pyrometer shall have readable graduations not larger than 5.5°C (10°F).

NOTE 1—The pyrometer equipment shall be standardized periodically by a suitably equipped standardizing laboratory such as that of the National Bureau of Standards, or checked periodically against equipment certified by the National Bureau of Standards.

5.3.2 *Thermocouple*—A thermocouple of platinum and platinum-rhodium, protected from the furnace gases by a glazed porcelain sheath, shall be used with a high-resistance millivoltmeter or potentiometer accurate and readable to within 5.5°C (10°F). The sheath shall be sealed to the furnace wall by alundum cement. The hot junction of the thermocouple shall touch the end of the sheath and shall be located in the center of the muffle and immediately to the rear of the cones. The thermocouple protective sheath shall be checked periodically for cracks. The thermocouple and its meter shall meet the requirements of Section 10. The potentiometer or millivoltmeter shall be located or shielded adequately as to prevent radiant or convection heating of the cold junction. The room temperature compensator shall be adjusted to the existing temperature.

5.4 *Ash-Cone Refractory Support*—The ash cone shall be mounted on a refractory base composed of a mixture of equal parts by weight of kaolin and alumina conforming to the following requirements:

5.4.1 *Kaolin*—NF-Grade powder passing a No. 200 (0.074 mm) sieve.

5.4.2 *Aluminum Oxide*—Reagent grade powder passing a No. 100 (0.149 mm) sieve.

5.5 *Refractory Support Mold*—A mold with flat top and bottom surfaces to provide a refractory support of suitable thickness to minimize warping shall be used. A side mold not over 1/4 in. (6.4 mm) high of any convenient shape, placed on an iron plate so that the top surface of the refractory mix can be struck off flat and parallel to the base by means of a straightedge, is satisfactory. For electric furnace use, legs not over 3 mm (1/8 in.) long may be provided on the corners of the cone support by suitable holes bored in the iron base plate of the mold.

5.6 *Gold Wire*,⁴ Twenty-four gage or larger round wire of 99.98 % purity, but drawn from metal of 99.99 % purity, and having a melting point of 1063°C (1945°F).

⁴ Gold wire of this purity can be purchased from the Baker Dental Division of Engelhard Industries, Inc., 850 Passaic Ave., East Newark, NJ 07029.