



Designation: D6880-05 Designation: D6880/D6880M - 11

Standard Specification for Wood Boxes¹

This standard is issued under the fixed designation D6880/D6880M; the number immediately following the designation indicates the year of original adoption or, in the case of revision, the year of last revision. A number in parentheses indicates the year of last reapproval. A superscript epsilon (ϵ) indicates an editorial change since the last revision or reapproval.

1. Scope

1.1 This specification covers the fabrication of wood boxes. These wood boxes, when constructed, filled and closed, shall be used for the packing of contents not exceeding ~~1,000~~1000 pounds [454 kg].

1.2 If the use of other construction methods or techniques is acceptable and permitted (see 5.1), the resulting boxes shall be of equal or better performance than would result from the use of the specified materials and procedures. An appropriate distribution cycle, specified in Practice D4169, can be used to develop comparative procedures and criteria.

1.3 The values stated in either inch-pound or SI units are to be regarded separately as standard. Within the text, the SI units are shown in brackets. The values stated in each system are not exact equivalents; therefore, each system must be used independently of the other. Combining values from the two systems may result in nonconformance with the standard. See ~~IEEE/ASTM SI-10~~ IEEE/ASTM SI-10 for conversion of units.

1.4 *This standard does not purport to address all of the safety concerns, if any, associated with its use. It is the responsibility of the user of this standard to establish appropriate safety and health practices and determine the applicability of regulatory limitations prior to use.*

2. Referenced Documents

2.1 ASTM Standards:²

D996 Terminology of Packaging and Distribution Environments

D3951 Practice for Commercial Packaging

D3953 Specification for Strapping, Flat Steel and Seals

D4169 Practice for Performance Testing of Shipping Containers and Systems

D4675 Guide for Selection and Use of Flat Strapping Materials

D6199 Practice for Quality of Wood Members of Containers and Pallets

D6253 Practice for Treatment and/or Marking of Wood Packaging Materials

F1667 Specification for Driven Fasteners: Nails, Spikes, and Staples

~~IEEE/ASTM SI-10~~IEEE/ASTM SI-10 Standard for Use of the International System of Units (SI): The Modernized Metric System

2.2 Federal Specification:

~~PPP-B-621~~Boxes, Wood, Nailed and Lock-Corner American Society of Mechanical Engineers (ASME) Standards:³

B18.2.1 Square and Hex Bolts and Screws-Inch Series

B18.2.2 Square and Hex Nuts (Inch Series)

B18.2.3.8M Metric Hex Lag Screws

B18.2.4.2M Metric Hex Nuts, Style 2

B18.5 Round Head Bolts (Inch Series)

B18.5.2.2M Metric round head Square Neck Bolts

B18.22M Metric Plain Washers

B18.22.1 Plain Washers

¹ This specification is under the jurisdiction of ASTM Committee D10 on Packaging and is the direct responsibility of Subcommittee D10.12 on Shipping Containers, Crates, Pallets, Skids, and Related Structures.

Current edition approved April 1, 2005. Published April 2005. DOI: 10.1520/D6880-05 on Shipping Containers, Crates, Pallets, Skids and Related Structures.

Current edition approved April 1, 2011. Published May 2011. Originally approved in 2005. Last previous edition approved in 2005 as D6880 - 05. DOI:10.1520/D6880_D6880M-11.

² For referenced ASTM standards, visit the ASTM website, www.astm.org, or contact ASTM Customer Service at service@astm.org. For Annual Book of ASTM Standards volume information, refer to the standard's Document Summary page on the ASTM website.

³ Available from the Federal Supply Service Bureau, Specification Section, Suite 8100, 480 L'Enfant Plaza, SW, Washington, DC 20408

³ Available from American Society of Mechanical Engineers (ASME), ASME International Headquarters, Three Park Ave., New York, NY 10016-5990, http://www.asme.org.

2.3 *American Softwood Lumber Standard PS-20*

National Institute of Standards and Technology (NIST) Standard:
PS-20 American Softwood Lumber Standard⁴

2.4 *American Wood Preservers' Association Standard*

National Hardwood Lumber Association (NHLA) Standard:
Rules for the Measurement and Inspection of Hardwood and Cypress⁵

2.5 *National Design Specification for Wood Construction American Wood Protection Association (AWPA) Standard:*⁶

P36 Standard for Copper Naphththenate (CuN)

P37 Standard for Oxine Copper (Copper-8-Quinolinolate) (Cu8)

2.6 *U.S Army Research, Development and Engineering Center (ARDEC):*

MIL-DTL-2427H Box, ammunition packing: Wood, nailed⁷

2.7 *International Standards for Phytosanitary Measures (ISPM) Publication:*

ISPM 15 Regulation of Wood Packaging Material in International Trade⁸

3. Terminology

3.1 *Definitions*—General definitions for packaging and distribution environments are found in Terminology D996.

3.2 *Definitions of Terms Specific to This Standard:*

3.2.1 *part*—a section of the box, such as top, bottom, side or end. *batten*—reinforcement on a box used to hold a series of boards together to create rigidity – generally set in from each end to prevent board splitting.

3.2.2 *piece*—a single solid piece of wood. *box*—a container with structural framework fastened together to form a rigid enclosure.

3.2.3 *cleat*—lumber used to strengthen or support the framework of a box.

3.2.4 *diagonal*—angle members placed between vertical and horizontal members within a component to provide rigidity to the box

4. Classification

4.1 Classes

Class 1 – Light Duty

Class 2 – Heavy Duty

4.2 Styles

Style 1 - Uncleated Ends (Fig. 1)

Style 2 - Full Cleated Ends, Butt Joints (Fig. 2)

Style 2-1/2 - Full Cleated Ends, Notched Cleats (Fig. 3)

Style 4 - Exterior End Cleats (Fig. 4)

Style 4 1/2 - Horizontal Exterior End Cleats (Fig. 4)

Style 5 - Interior End Cleats (Fig. 5)

Style 7 - Skidded Base with Separate Hood (Fig. 6)

4.3 Water-Repellent Wood Preservative Treatment

Treatment A - Without treatment

Treatment B - With treatment

5. Ordering Information

5.1 Purchasers should include the following information in procurement documents:

5.1.1 Specification title, number and date.

5.1.2 Box class, style and treatment (see 4.1-4.3).

5.1.3 Description of contents and contents weight, if known.

5.1.4 When alternate materials and construction methods are acceptable and permitted (see 1.2).

5.1.5 Inside box dimensions. (see

5.1.5 Inside box dimensions specified in inches [mm] in order of length by width by height. (see 7.1).

5.1.6 When cleats are cut or notched for water drainage (see 7.3).

⁴ Available from National Institute of Standards and Technology, U.S. Department of Commerce, 100 Bureau Dr, Stop 3460, Gaithersburg, MD 20899-3460

⁴ Available from National Institute of Standards and Technology (NIST), 100 Bureau Dr., Stop 1070, Gaithersburg, MD 20899-1070, <http://www.nist.gov>.

⁵ Available from American Wood Preservers' Association (AWPA), P.O. Box 5690, Granbury, TX 76049-0690

⁵ Available from National Hardwood Lumber Association (NHLA), 6830 Raleigh LaGrange Rd., Memphis, TN 38134, <http://www.natllhardwood.org>

⁶ Available from American Forest and Paper Association, American Wood Council, 1111 19th St. NW, Suite 800 Washington, DC 20036

⁶ Available from American Wood Protection Association (AWPA), P.O. Box 361784, Birmingham, AL 35236-1784, <http://www.awpa.org>.

⁷ Available from ASSIST Quick search, <http://assist.daps.dla.mil>.

⁸ Available from the International Plant Protection Convention, <http://www.ippc.int>.

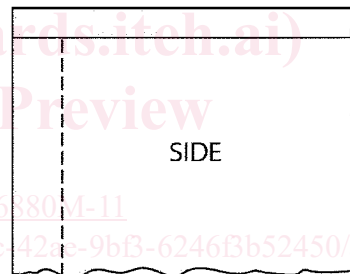
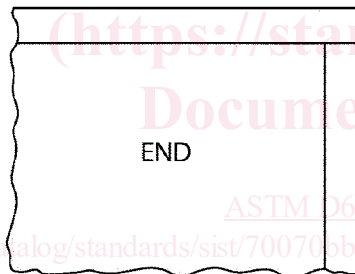
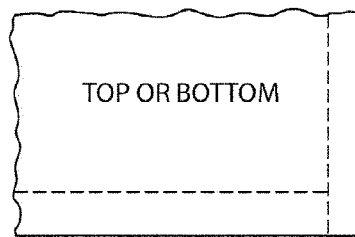
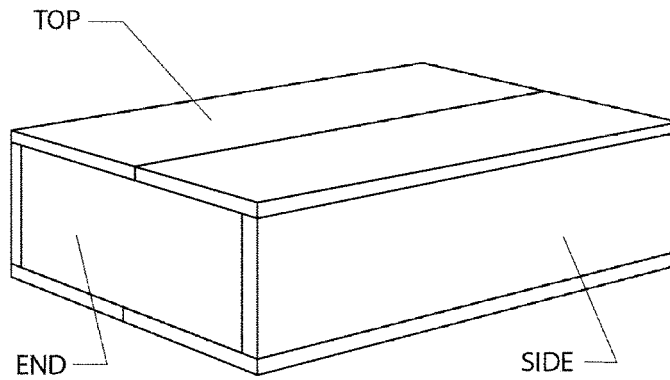

FIG. 1 Style 1 Box (Uncleated Ends)

- ~~5.1.7~~When skids are required (see 5.1.7).
- 5.1.7 When 2- or 4-way entry skids are required (see 7.4).
- ~~5.1.8~~When 4-way entry skids are required (see 7.4):
- 5.1.9
- 5.1.8 When rubbing strips are required (see 7.4).
- 5.1.10
- 5.1.9 When beveled skids are required (see 7.4).
- 5.1.10 When re-closable top panel closure is required (see 7.5-17.2.1).
- ~~5.1.12~~When marking of boxes is required (see 7.9).
- 5.1.11 When water-repellant wood preservative treatment is required (see 7.6).
- 5.1.12 When boxes are shipped assembled or knocked down (see 8.1).
- 5.1.13 When special packing and marking of boxes are required (see 7.9).
- ~~5.1.13~~When boxes are shipped assembled or knocked down (see 7.12 and 7.13).
- 5.1.14 When ISPM 15-compliance is required (see 8.3).

6. Material

6.1 *Materials*: ~~All materials shall meet the requirements of this specification and referenced documents. Materials shall not affect or be affected by the product being packed. The use of recycled material is encouraged.~~ All materials shall meet the requirements of this specification and referenced documents. Materials shall be free of defects, which adversely affect performance or serviceability of the finished box. Materials shall not affect or be affected by the product being packed. The use of recycled

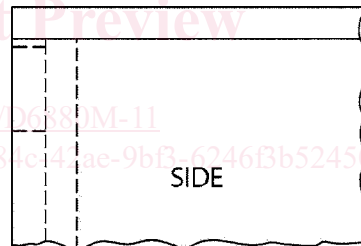
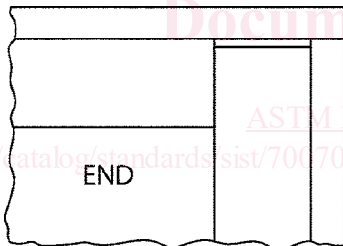
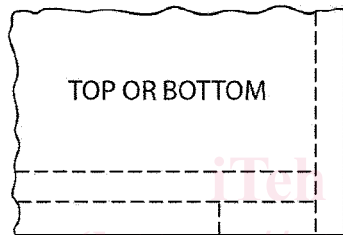
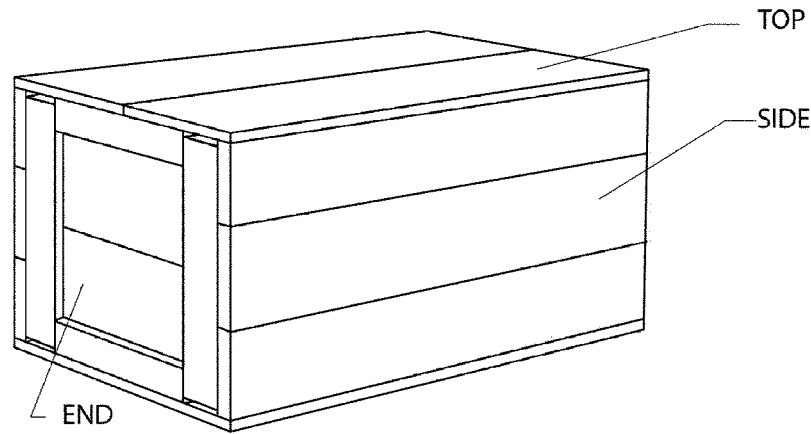

FIG. 2 Style 2 Box (Full Cleated Ends, Butt Joints)

material is encouraged. All virgin, recycled and repair materials used in box manufacturing shall meet the requirements of this specification and the referenced documents.

6.1.1 *Wood Lumber*. Wood Lumber shall conform to Practice D6199 or the American Softwood Lumber Standard PS-20, as applicable, PS-20, or the NHLA rules, as applicable. Tables 1 and 2 cite nominal dimensions for wood pieces (commercial tolerances will apply). Thicker or wider pieces of wood are acceptable. For cleats, battens and diagonals, the wood shall conform to Class 1 or 2 of Practice D6199. cite nominal dimensions for wood pieces (commercial tolerances will apply). Thicker or wider pieces is acceptable.

6.1.2 *Fasteners*. Fasteners (bolts, nuts, screws, staples, and so forth) shall meet the stress design criteria of the National Design Specification for Wood Construction. Fasteners are classified as nails, lag bolts, bolts, nuts, screws, staples, and straps.

6.1.2.1 *Nails*. Nails shall conform to Specification F1667 :

6.1.2.1.1 *and other industry standards*. Nails are classified as plainshank, helically threaded, annularly threaded, fluted, or twisted square wire.

6.1.2.2 *Lag bolts, bolts, screws, nuts and washers*. Lag bolts, bolts, screws, nuts and washers conform to ASME B18.2.1, (B18.2.3.8M), ASME B18.5 (B18.5.2.2M), ASME B18.2.2 (B18.2.4.2M), ASME B18.22.1 (B18.22M), and other industry standards.

6.1.2.3 *Metallic Straps*—Strapping used to reinforce box shall conform to Specification D3953, Guide D4675, and other industry standards.

6.1.3 *Preservatives*. Preservatives shall conform to the properties and formulations of either copper naphthenate, zinc naphthenate or oxine copper (copper-8-quinolinolate) as cited in American Wood Preservers' Association (AWPA) Standard P8 and

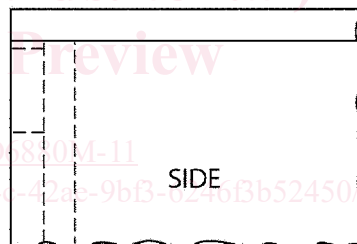
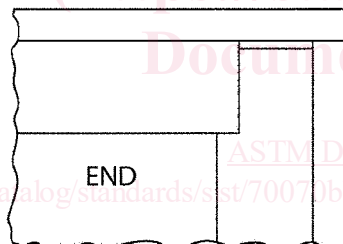
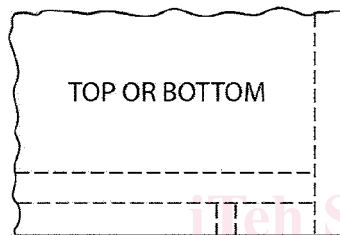
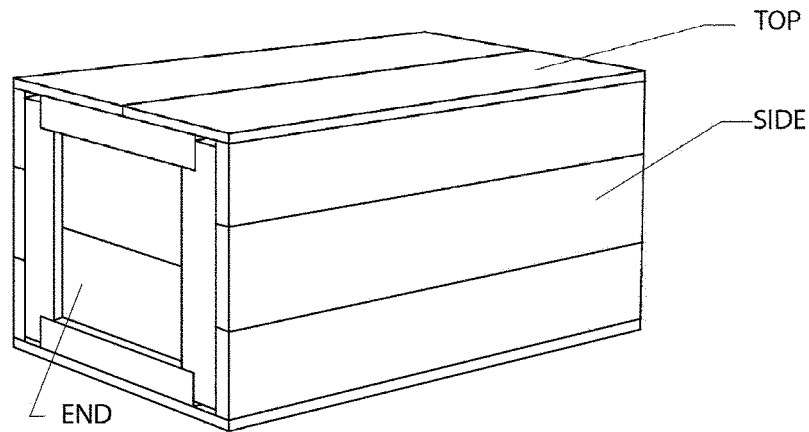

FIG. 3 Style 2-½ Box (Full Cleated Ends; Notched Cleats)

P9. Water-repellent wood preservatives shall be a solution containing either copper naphthenate, conforming with Practice D6253, MIL-DTL-2427H and AWWA Standards P36 with a minimum concentration of 2.0 % copper metal, oxine copper (formerly referred to as copper-8-quinolinolate) conforming with Practice D6253, MIL-DTL-2427H and AWWA Standard P37 with a minimum concentration of 1.8 % copper metal, or 3 % zinc naphthenate conforming with Practice D6253 and MIL-DTL-2427H.

7. Construction

7.1 *Dimensions.* Boxes shall be designed to the cited inside length, width and depth (see 5.1.4). A tolerance of $-0, +\frac{1}{4}$ inch [6 mm] shall be permitted.

7.2 *Box sides, tops, bottoms and ends.* Wood thickness shall be as specified in Tables 1 and 2. ~~No piece shall be less than 3 in. [76 mm] wide. When a side, top, bottom or end is constructed from more than one piece, the pieces shall be joined with fasteners or adhesive.~~ No piece shall be less than 2 in. [50 mm] wide. When a side, top, bottom or end is constructed from more than one piece, the pieces shall be joined with fasteners or adhesive.

7.2.1 *Re-closable top panel closure.* The top shall be constructed with cleats on the underside that fits snugly inside the box sides and ends. Closure can be completed with strapping, screws, bolts or other fasteners to allow easy opening and reclosure.

7.3 *Cleats, battens and diagonals.* Tables 1 and 2 cite the required wood thickness and width. ~~Pieces~~ Wood shall be one piece up to 12 ft [3.7 m] in length. Longer cleats shall be no more than two pieces, with no piece less than 3 ft [91 cm] long. Cleats may be cut or notched to provide for water drainage (see 5.1.6). ~~drainage.~~

7.4 *Skids.* When a box is intended for use with loads resulting in a gross weight in excess of 200 pounds [91 kg] or boxes with a gross weight in excess of 100 pounds [45 kg] and a box length and width of 48 inches [1219 mm] by 24 inches [610 mm]

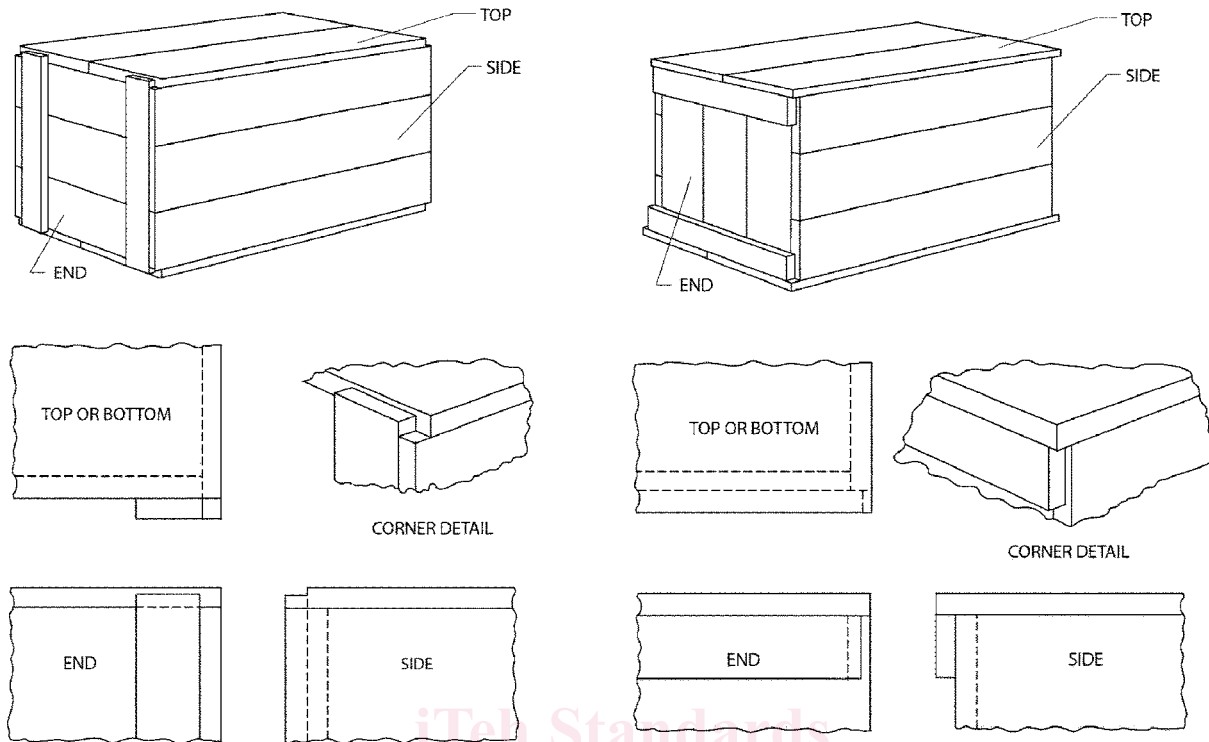

FIG. 4 Style 4 and 4-1/2 (Exterior End Cleats)

or more, the box shall be fitted with skids. Skids shall measure a minimum of 2-1/2 inches [64 mm] high and 3-1/2 inches [89 mm] wide. Skids shall be placed parallel to and extend the full width of the box and shall be positioned not closer than 2-1/2 inches [64 mm] nor more than 1/4 the box length from each end of the box. The distance between inside edges of skids shall not exceed 48 inches [1219 mm]. Additional skids, as required, shall be positioned so as to divide the distance between skids into equal distances. When bolt fastening is provided for the item being packed, skids shall be located to enable the item to be bolted to the skids. Skids shall be fastened to the box. When 4-way fork entry is required, skids shall be a minimum of 3-1/2 by 3-1/2 inches [89 by 89 mm], and cut out a minimum of 2 inches [51 mm] in depth and of such width as to accommodate forks and slings for handling. Note that forks are normally 6 by 2 inches in shape and are set 27 inches apart, outside to outside dimension. Skids may be built with rubbing strips (see 5.1.105.1.8). Skids may be beveled to facilitate pushing or dragging of loads (see 5.1.105.1.9).

7.5 Fastening of pieces and parts. Fastener spacing shall not exceed 4 inches [102 mm]; except tops, where spacing shall not exceed 6 inches. Nails shall be located to minimize splitting of wood. Overdriving of fasteners is discouraged. If fasteners are overdriven, protruding points shall be clinched or covered.

7.5.1 Re-closable top panel closure. The top shall be constructed with cleats on the underside that fit snugly inside the box sides and ends. Closure can be completed with strapping (see Guide D4675), screws, bolts or other fasteners to allow easy opening and re-closure:

7.6 Fastener spacing shall not exceed 4 in. [102 mm]; except tops, where spacing shall not exceed 6 inches. Nails shall be located to minimize splitting of wood. Overdriving of fasteners is discouraged. If fasteners are overdriven, protruding points shall be clinched or covered.

7.6 Preservation. When boxes are treated with preservative, all exterior surfaces of the box shall be treated. All safety and environmental regulations shall be followed.

7.7 Box styles.

7.7.1 Style 1, Uncleated Ends (Fig. 1). A recommended maximum box size is the sum of the length, width and height should not exceed 50 inches (1.3 m) in. [1.3 m].

7.7.2 Style 2, Full Cleated Ends, Butt Joints (Fig. 2). The sides, top, and bottom shall be flush with the outside surface of the four cleats at each end.

7.7.3 Style 2-1/2, Full Cleated Ends, Notched Cleats (Fig. 3). The four cleats at each end shall be notched. The sides, top, and bottom shall be flush with the outside surface of the four cleats at each end.

7.7.4 Style 4, Exterior End Cleats (Fig. 4). Each end shall have two vertical exterior cleats.

7.7.5 Style 4 1/2, Horizontal Exterior End Cleats (Fig. 4). Each end shall have two horizontal exterior cleats.