

---

---

**Road vehicles — Tachograph  
systems —**

**Part 1:  
Electromechanical components**

*Véhicules routiers — Systèmes tachygraphes —  
Partie 1: Composants électromécaniques*

iTeh STANDARD PREVIEW  
(standards.iteh.ai)

[ISO 16844-1:2022](https://standards.iteh.ai/catalog/standards/sist/f6c40de-f66e-4a59-9571-c9c4b433b8c6/iso-16844-1-2022)

<https://standards.iteh.ai/catalog/standards/sist/f6c40de-f66e-4a59-9571-c9c4b433b8c6/iso-16844-1-2022>



iTeh STANDARD PREVIEW  
(standards.iteh.ai)

ISO 16844-1:2022

<https://standards.iteh.ai/catalog/standards/sist/f6ec40de-f66e-4a59-9571-c9c4b433b8c6/iso-16844-1-2022>



**COPYRIGHT PROTECTED DOCUMENT**

© ISO 2022

All rights reserved. Unless otherwise specified, or required in the context of its implementation, no part of this publication may be reproduced or utilized otherwise in any form or by any means, electronic or mechanical, including photocopying, or posting on the internet or an intranet, without prior written permission. Permission can be requested from either ISO at the address below or ISO's member body in the country of the requester.

ISO copyright office  
CP 401 • Ch. de Blandonnet 8  
CH-1214 Vernier, Geneva  
Phone: +41 22 749 01 11  
Email: [copyright@iso.org](mailto:copyright@iso.org)  
Website: [www.iso.org](http://www.iso.org)

Published in Switzerland

# Contents

	Page
Foreword.....	iv
Introduction.....	v
<b>1 Scope</b> .....	<b>1</b>
<b>2 Normative references</b> .....	<b>1</b>
<b>3 Terms and definitions</b> .....	<b>1</b>
<b>4 Abbreviated terms</b> .....	<b>1</b>
<b>5 Connector dimensions</b> .....	<b>1</b>
<b>6 Contact allocation</b> .....	<b>3</b>
6.1 Connector parts A and B.....	3
6.2 Connector parts C and D.....	4
<b>7 Performance — Tests and requirements</b> .....	<b>4</b>
7.1 General.....	4
7.2 Temperature/humidity cycling.....	5
7.3 Combined temperature/vibration.....	5
7.4 Dielectric strength.....	5
7.5 Mechanical shock and chemical fluids.....	5
<b>Bibliography</b> .....	<b>6</b>

ITeH STANDARD PREVIEW  
(standards.iteh.ai)

[ISO 16844-1:2022](https://standards.iteh.ai/catalog/standards/sist/f66e-4a59-9571-c9c4b433b8c6/iso-16844-1-2022)

<https://standards.iteh.ai/catalog/standards/sist/f66e-4a59-9571-c9c4b433b8c6/iso-16844-1-2022>

## Foreword

ISO (the International Organization for Standardization) is a worldwide federation of national standards bodies (ISO member bodies). The work of preparing International Standards is normally carried out through ISO technical committees. Each member body interested in a subject for which a technical committee has been established has the right to be represented on that committee. International organizations, governmental and non-governmental, in liaison with ISO, also take part in the work. ISO collaborates closely with the International Electrotechnical Commission (IEC) on all matters of electrotechnical standardization.

The procedures used to develop this document and those intended for its further maintenance are described in the ISO/IEC Directives, Part 1. In particular, the different approval criteria needed for the different types of ISO documents should be noted. This document was drafted in accordance with the editorial rules of the ISO/IEC Directives, Part 2 (see [www.iso.org/directives](http://www.iso.org/directives)).

Attention is drawn to the possibility that some of the elements of this document may be the subject of patent rights. ISO shall not be held responsible for identifying any or all such patent rights. Details of any patent rights identified during the development of the document will be in the Introduction and/or on the ISO list of patent declarations received (see [www.iso.org/patents](http://www.iso.org/patents)).

Any trade name used in this document is information given for the convenience of users and does not constitute an endorsement.

For an explanation of the voluntary nature of standards, the meaning of ISO specific terms and expressions related to conformity assessment, as well as information about ISO's adherence to the World Trade Organization (WTO) principles in the Technical Barriers to Trade (TBT), see [www.iso.org/iso/foreword.html](http://www.iso.org/iso/foreword.html).

This document was prepared by Technical Committee ISO/TC 22, *Road vehicles*, Subcommittee SC 31, *Data communication*.

This third edition cancels and replaces the second edition (ISO 16844-1:2013), which has been technically revised.

The main changes are as follows:

- part 5 of this series (ISO 16844-5) has been removed due to its technical irrelevance,
- correction of the typos and mistakes in the text,
- adoption of the content according to the new version of the ISO guidelines,
- adoption of the content according to the new technical requirements,
- alignment of the content regarding to the referred standards.

A list of all parts in the ISO 16844 series can be found on the ISO website.

Any feedback or questions on this document should be directed to the user's national standards body. A complete listing of these bodies can be found at [www.iso.org/members.html](http://www.iso.org/members.html).

## Introduction

This document supports and facilitates the communication between electronic control units (ECUs) and a digital tachograph.

The digital tachograph concept is based upon a recording equipment storing data, related to the activities of the various drivers driving the vehicle, on which it is installed.

During the normal operational status of the recording equipment, data stored in its memory are accessible to different entities (drivers, authorities, workshops, transport companies) in different ways (displayed on a screen, printed by a printing device, downloaded to an external device). Access to stored data is controlled by a smart card inserted in the tachograph.

A typical tachograph system is shown in [Figure 1](#).

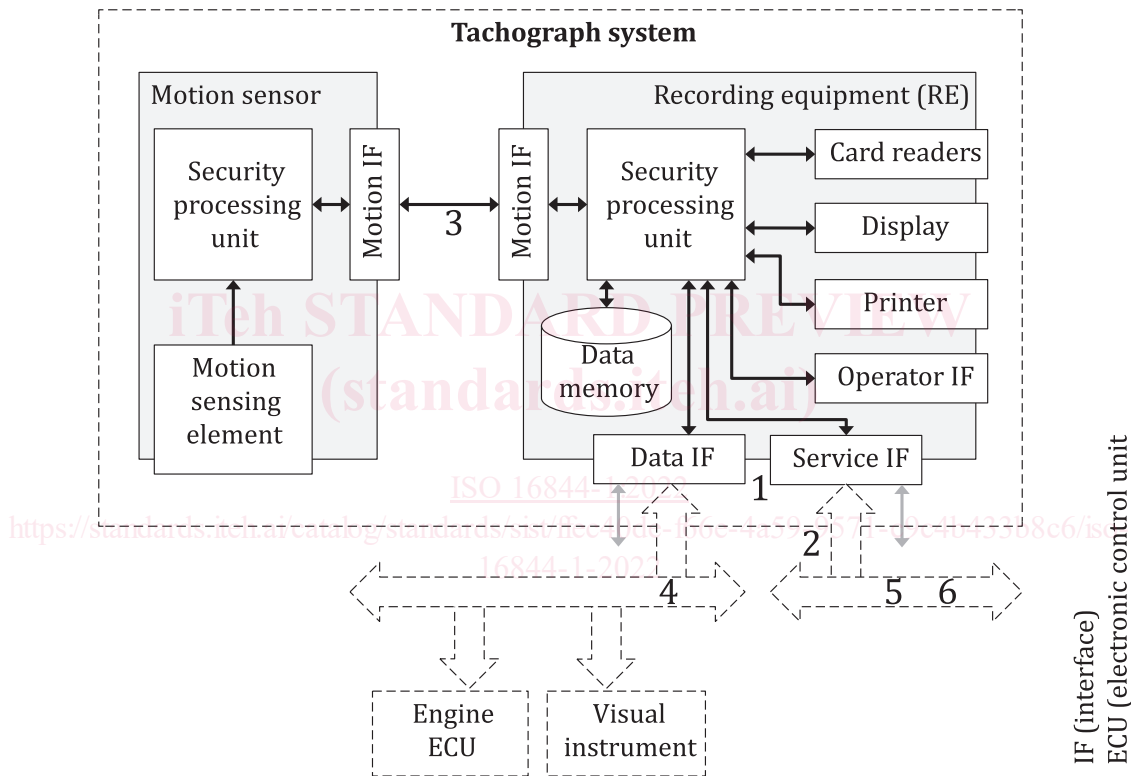

### Key

- |  |   |
|--|---|
| 1 data and service IF connector standardized in ISO 16844-1                        | 4 CAN-based data IF including parameter groups standardized in ISO 16844-4                    |
| 2 electrical data and service IF requirements standardized in ISO 16844-2          | 5 optional CAN-based service IF standardized in ISO 16844-6                                   |
| 3 communication interface between motion sensor and RE standardized in ISO 16844-3 | 6 data identifier (DID) specification for the optional service IF standardized in ISO 16844-7 |

**Figure 1 — Typical ISO 16844-conformant tachograph system**



# Road vehicles — Tachograph systems —

## Part 1: Electromechanical components

### 1 Scope

This document specifies the mechanical dimensions of mandatory connectors and optional connectors used by the recording equipment for the data and the service interfaces. This includes, in particular, the connection to the CAN-based in-vehicle networks.

### 2 Normative references

The following documents are referred to in the text in such a way that some or all of their content constitutes requirements of this document. For dated references, only the edition cited applies. For undated references, the latest edition of the referenced document (including any amendments) applies.

ISO 8092-2:2005, *Road vehicles — Connections for on-board electrical wiring harnesses — Part 2: Definitions, test methods and general performance requirements*

### 3 Terms and definitions

For the purposes of this document, the following terms and definitions apply.

ISO and IEC maintain terminology databases for use in standardization at the following addresses:

- ISO Online browsing platform: available at <https://www.iso.org/obp>
- IEC Electropedia: available at <https://www.electropedia.org/>

#### 3.1

##### **tachograph**

intended for installation in road vehicles to display, record, print, store and output automatically or semi-automatically details of the movement, including the speed, of such vehicles, and details of certain periods of activity of their drivers

#### 3.2

##### **recording equipment**

equipment which includes a *tachograph* (3.1), cables and a motion sensor

### 4 Abbreviated terms

CAN controller area network

ECU electronic control unit

IF interface

### 5 Connector dimensions

[Figure 2](#) specifies dimensions of the connectors of a recording equipment.

Dimensions in millimetres

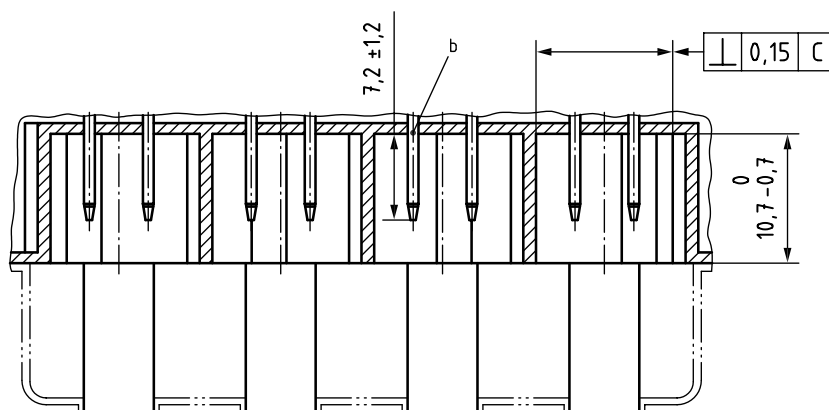
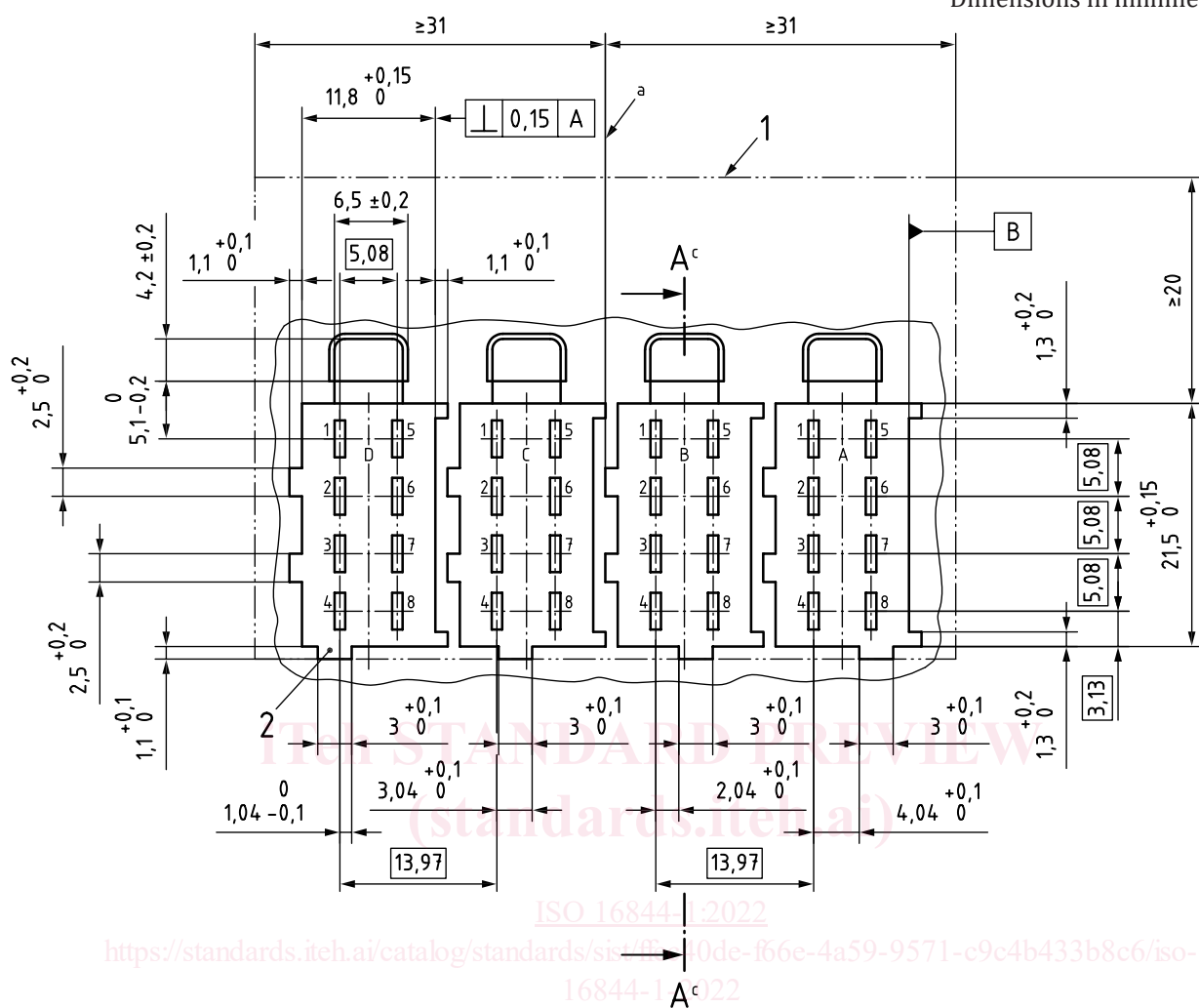

**Key**

- 1 free space to decouple the connector parts                      2 coding key
- a Module A and module B as well as module C and module D may be separated. In case of separation, dimension 13,97 becomes 2 × 6,985.
- b Contact tab according to ISO 8092-3, 2,8 × 0,8. A tab width up to 3,1 mm may be used for existing units, but the length is limited to 6,8 mm max.
- c Section A-A, see [Figure 3](#).

**Figure 2 — Recording equipment connector dimensions**



Dimensions in millimetres (minimum and maximum values are given, where applicable)

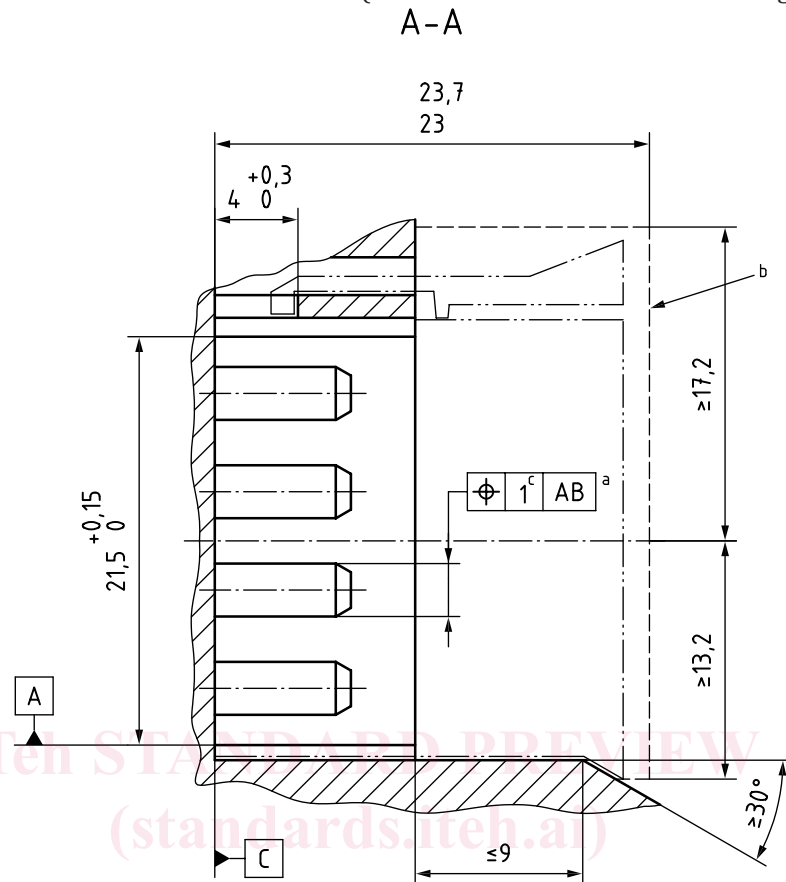

**Key**

- a All contact tabs.
- b Requested space for socket housing (space for disconnection and cable not shown).
- c Linear increase from 0,12 at the level of datum plane “C” up to 0,4 at the top of the tabs.

Figure 3 — Section A-A (see Figure 2)

## 6 Contact allocation

### 6.1 Connector parts A and B

The contact allocation of the connector, parts A and B, are specified in Table 1. The connector parts D, C, and contact B8 may be used.

Table 1 — Contact allocation of connector, parts A and B

Connector contact No.	Description
A1	Permanent power +
A2	Illumination
A3	Ignition
A4	CAN1_H
A5	Battery minus
A6	Ground, GND

**Table 1** (continued)

Connector contact No.	Description
A7	CAN1_GND
A8	CAN1_L
B1	Positive supply
B2	Battery minus
B3	Speed signal, real time
B4	Data signal
B5	Manufacturer-specific
B6	Speed pulse output
B7	Speed pulse output
B8	Distance signal, 4 pulses/m

## 6.2 Connector parts C and D

The contact allocation of the optional connector, parts C and D, and contact B8 shall be as given in [Table 1](#) and [Table 2](#).

**Table 2 — Contact allocation of connector, parts C and D**

Connector contact No.	Description
C1	Manufacturer-specific
C2	Manufacturer-specific
C3	Manufacturer-specific
C4	Manufacturer-specific
C5	CAN2_H
C6	CAN2_GND
C7	CAN2_L
C8	Manufacturer-specific
D1	Status input 1
D2	Status input 2
D3	Manufacturer-specific
D4	General tachograph warning output
D5	Manufacturer-specific
D6	Speed pulse output for instrument
D7	Data communication I/O
D8	Manufacturer-specific

## 7 Performance — Tests and requirements

### 7.1 General

The connector shall be tested according to and fulfil the requirements according to ISO 8092-2 with the following provisions and exceptions.