

INTERNATIONAL STANDARD

ISO
2725

Second edition
1987-08-01



INTERNATIONAL ORGANIZATION FOR STANDARDIZATION
ORGANISATION INTERNATIONALE DE NORMALISATION
МЕЖДУНАРОДНАЯ ОРГАНИЗАЦИЯ ПО СТАНДАРТИЗАЦИИ

Assembly tools for screws and nuts — Machine- and hand-operated square drive sockets — Metric series

Outils de manœuvre pour vis et écrous — Douilles à carré conducteur femelle, à machine et à main — Série métrique

(standards.iteh.ai)

ISO 2725:1987

<https://standards.iteh.ai/catalog/standards/sist/bdd419dc-8428-4e39-8e1d-afe1fd0f280/iso-2725-1987>

Reference number
ISO 2725 : 1987 (E)

Foreword

ISO (the International Organization for Standardization) is a worldwide federation of national standards bodies (ISO member bodies). The work of preparing International Standards is normally carried out through ISO technical committees. Each member body interested in a subject for which a technical committee has been established has the right to be represented on that committee. International organizations, governmental and non-governmental, in liaison with ISO, also take part in the work.

Draft International Standards adopted by the technical committees are circulated to the member bodies for approval before their acceptance as International Standards by the ISO Council. They are approved in accordance with ISO procedures requiring at least 75 % approval by the member bodies voting.

International Standard ISO 2725 was prepared by Technical Committee ISO/TC 29, *Small tools*.

This second edition cancels and replaces the first edition (ISO 2725:1973), of which it constitutes a technical revision. <https://standards.iteh.ai/catalog/standards/sist/bdd419dc-8428-4e39-8e1d-afe1ff0f280/iso-2725-1987>

Users should note that all International Standards undergo revision from time to time and that any reference made herein to any other International Standard implies its latest edition, unless otherwise stated.

Assembly tools for screws and nuts — Machine- and hand-operated square drive sockets — Metric series

iTeh STANDARD PREVIEW
(standards.iteh.ai)

1 Scope and field of application

This International Standard, relating to assembly tools for screws and nuts, lays down the dimensions of machine- and hand-operated square drive sockets (for socket wrenches) with operating end having a hexagon and double hexagon form.

The driving squares are in conformity with ISO 1174.

The hand-operated sockets shall satisfy the technical specifications given in ISO 1711.

The figures in this International Standard are given only as examples. They not intended to influence the manufacturer's design.

2 References

ISO 691, *Wrench and socket openings — Metric series — Tolerances for general use.*

ISO 1174, *Assembly tools for bolts and screws — Driving squares for power socket wrenches and hand socket wrenches.*

ISO 1711, *Hand operated wrenches and sockets — Technical specifications.*

3 Tolerances across flats

Tolerances across flats, s , shall be in conformity with the tolerances for socket openings given in ISO 691. Manufacturers are free to choose the series of deviations.

4 Machine-operated square drive sockets (IMPACT)

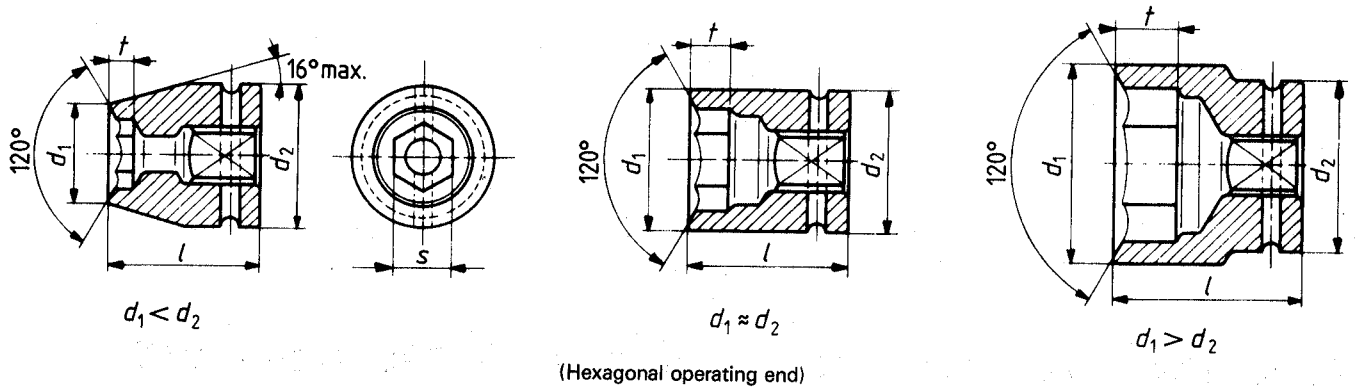

Dimensions in millimetres

Across flats		Driving square ¹⁾																									
		6,3			10			12,5			16																
s ²⁾	t min.	d ₁ max.	d ₂ max.	l max.	d ₁ max.	d ₂ max.	l max.	d ₁ max.	d ₂ max.	l max.	d ₁ max.	d ₂ max.	l max.														
3,2	1,1	6,8	14	25	12,8	14,1	20	15,3	16,5	28	40	25,0	35	48													
4	1,4	7,8																									
5	1,7	9,1																									
5,5	2,1	9,7																									
6	2,4	10,3																									
7	2,8	11,6																									
8	3,5	12,8	16	28	14,1	20	15,3	28	16,5	37	40	25,0	35	48													
9	3,5	14,1																									
10	4,2	15,3																									
11	4,9	16,6																									
12	5,6	17,8																									
13		19,1																									
14	7,0	19,1	16	25	12,8	14,1	20	15,3	16,5	28	40	25,0	35	48													
15															21,6												
16															22,8												
17															24,1												
18															25,3												
19															26,6												
21	9,8	19,1	16	25	12,8	14,1	20	15,3	16,5	28	40	25,0	35	48													
22															21,6												
24															22,8												
27															24,1												
30															25,3												
32															26,6												
34	11,2	19,1	16	25	12,8	14,1	20	15,3	16,5	28	40	25,0	35	48													
36															27,8												
30	14,0	19,1	16	25	12,8	14,1	20	15,3	16,5	28	40	25,0	35	48													
32	15,4														31,3												
34															33,8												
36	35,0																										
30	16,8														19,1	16	25	12,8	14,1	20	15,3	16,5	28	40	25,0	35	48
32																											
34	41,3																										
36	45,0																										

1) In accordance with ISO 1174.
 2) Tolerances in accordance with ISO 691.

Dimensions in millimetres

Across flats		Driving square ¹⁾											
		20			25			40					
s ²⁾	t min.	d ₁ max.	d ₂ max.	l max.	d ₁ max.	d ₂ max.	l max.	d ₁ max.	d ₂ max.	l max.			
18	8,4	32,4	48	51	54	58	60	86	86	95			
19		33,6											
21	9,8	36,1											
22		37,4											
24		39,9											
27	12,6	43,6		58	57	62	63				67	70,4	76,7
30	14,0	47,4											
32	15,4	49,9											
34		52,4											
36		54,9											
41	18,9	61,1	68		63	68	70	76,7	81,7				
46	21,0	67,4											
50	23,1												
55	25,2												
60	27,3												

- 1) In accordance with ISO 1174.
- 2) Tolerances in accordance with ISO 691.

iTeh STANDARD PREVIEW
(standards.iteh.ai)

ISO 2725:1987

<https://standards.iteh.ai/catalog/standards/sist/bdd419dc-8428-4e39-8e1d-afe1fd0f280/iso-2725-1987>

iTeh STANDARD PREVIEW
(standards.iteh.ai)

ISO 2725:1987

<https://standards.iteh.ai/catalog/standards/sist/bdd419dc-8428-4e39-8e1d-afe1fd0f280/iso-2725-1987>

UDC 621.883

Descriptors : tools, assembly tools, power-operated tools, hand tools, socket wrenches, driving square, dimensions.

Price based on 4 pages
