



SLOVENSKI STANDARD SIST ISO 2137:2021

01-november-2021

Nadomešča:
SIST ISO 2137:2008

Naftni proizvodi in maziva - Določevanje penetracije s stožcem za mazalne masti in vazeline

Petroleum products and lubricants - Determination of cone penetration of lubricating greases and petrolatum

iTeh STANDARD PREVIEW
(standards.iteh.ai)

Produits pétroliers et lubrifiants - détermination de la pénétrabilité au cône des graisses lubrifiantes et des pétrolatums

[SIST ISO 2137:2021](https://standards.iteh.ai/catalog/standards/sist/c1aca5ba-dc52-47f9-93bd-93cbe9a73a7/sist-iso-2137-2021)

[https://standards.iteh.ai/catalog/standards/sist/c1aca5ba-dc52-47f9-93bd-](https://standards.iteh.ai/catalog/standards/sist/c1aca5ba-dc52-47f9-93bd-93cbe9a73a7/sist-iso-2137-2021)

[93cbe9a73a7/sist-iso-2137-2021](https://standards.iteh.ai/catalog/standards/sist/c1aca5ba-dc52-47f9-93bd-93cbe9a73a7/sist-iso-2137-2021)

Ta slovenski standard je istoveten z: ISO 2137:2020

ICS:

75.100	Maziva	Lubricants, industrial oils and related products
75.140	Voski, bitumni in drugi naftni proizvodi	Waxes, bituminous materials and other petroleum products

SIST ISO 2137:2021

en,fr

iTeh STANDARD PREVIEW
(standards.iteh.ai)

SIST ISO 2137:2021

<https://standards.iteh.ai/catalog/standards/sist/c1aca5ba-dc52-47f9-93bd-93cbe9a73a7/sist-iso-2137-2021>

INTERNATIONAL
STANDARD

ISO
2137

Fourth edition
2020-05

**Petroleum products and lubricants —
Determination of cone penetration of
lubricating greases and petrolatum**

iTeh STANDARD PREVIEW
(standards.iteh.ai)

[SIST ISO 2137:2021](https://standards.iteh.ai/catalog/standards/sist/c1aca5ba-dc52-47f9-93bd-93cbe9a73a7/sist-iso-2137-2021)

<https://standards.iteh.ai/catalog/standards/sist/c1aca5ba-dc52-47f9-93bd-93cbe9a73a7/sist-iso-2137-2021>



Reference number
ISO 2137:2020(E)

© ISO 2020

iTeh STANDARD PREVIEW (standards.iteh.ai)

SIST ISO 2137:2021

<https://standards.iteh.ai/catalog/standards/sist/c1aca5ba-dc52-47f9-93bd-93cbe9a73a7/sist-iso-2137-2021>



COPYRIGHT PROTECTED DOCUMENT

© ISO 2020

All rights reserved. Unless otherwise specified, or required in the context of its implementation, no part of this publication may be reproduced or utilized otherwise in any form or by any means, electronic or mechanical, including photocopying, or posting on the internet or an intranet, without prior written permission. Permission can be requested from either ISO at the address below or ISO's member body in the country of the requester.

ISO copyright office
CP 401 • Ch. de Blandonnet 8
CH-1214 Vernier, Geneva
Phone: +41 22 749 01 11
Fax: +41 22 749 09 47
Email: copyright@iso.org
Website: www.iso.org

Published in Switzerland

Contents

Page

Foreword	v
Introduction	vi
1 Scope	1
2 Normative references	1
3 Terms and definitions	1
4 Principle	2
5 Classifications, procedures and limitation	2
6 Apparatus	3
7 Sampling	14
8 Procedures for lubricating grease using full-scale methods	14
8.1 Procedure for unworked penetration.....	14
8.1.1 Preparation of test portion.....	14
8.1.2 Cleaning the cone and movable attachments.....	14
8.1.3 Penetration measurement.....	14
8.2 Procedure for worked penetration.....	15
8.2.1 Preparation of test sample.....	15
8.2.2 Preparation of test portion.....	15
8.2.3 Penetration measurement.....	16
8.3 Procedure for prolonged worked penetration.....	16
8.3.1 Preparation of apparatus and test portion.....	16
8.3.2 Penetration measurement.....	16
8.4 Procedure for block penetration.....	17
8.4.1 Preparation of test portion.....	17
8.4.2 Penetration measurement.....	17
8.4.3 Additional determinations.....	17
9 Procedures for lubricating grease using one-half-scale and one-quarter-scale cone method	17
9.1 General.....	17
9.2 Procedure for unworked penetration.....	18
9.2.1 Preparation of test portion.....	18
9.2.2 Cleaning cone and movable attachments.....	18
9.2.3 Penetration measurement.....	18
9.3 Procedure for worked penetration.....	18
9.3.1 Preparation of test sample.....	18
9.3.2 Preparation of test portion.....	18
9.3.3 Penetration measurement.....	19
10 Procedure for determining the cone penetration of petrolatum	19
10.1 Preparation of the test portion.....	19
10.2 Penetration measurement.....	19
11 Calculation	20
11.1 Calculation of full-scale penetration.....	20
11.2 Conversion to full-scale penetration for the one-half-scale and one-quarter-scale cones.....	20
11.2.1 General.....	20
11.2.2 One-quarter-scale cone.....	20
11.2.3 One-half-scale cone.....	20
12 Expression of results	20
13 Precision	20
13.1 General.....	20
13.2 Repeatability, <i>r</i>	20

ISO 2137:2020(E)

13.3	Reproducibility, <i>R</i>	20
14	Test report	21
	Bibliography	22

iTeh STANDARD PREVIEW
(standards.iteh.ai)

[SIST ISO 2137:2021](https://standards.iteh.ai/catalog/standards/sist/c1aca5ba-dc52-47f9-93bd-93cbe9a73a7/sist-iso-2137-2021)

<https://standards.iteh.ai/catalog/standards/sist/c1aca5ba-dc52-47f9-93bd-93cbe9a73a7/sist-iso-2137-2021>

Foreword

ISO (the International Organization for Standardization) is a worldwide federation of national standards bodies (ISO member bodies). The work of preparing International Standards is normally carried out through ISO technical committees. Each member body interested in a subject for which a technical committee has been established has the right to be represented on that committee. International organizations, governmental and non-governmental, in liaison with ISO, also take part in the work. ISO collaborates closely with the International Electrotechnical Commission (IEC) on all matters of electrotechnical standardization.

The procedures used to develop this document and those intended for its further maintenance are described in the ISO/IEC Directives, Part 1. In particular, the different approval criteria needed for the different types of ISO documents should be noted. This document was drafted in accordance with the editorial rules of the ISO/IEC Directives, Part 2 (see www.iso.org/directives).

Attention is drawn to the possibility that some of the elements of this document may be the subject of patent rights. ISO shall not be held responsible for identifying any or all such patent rights. Details of any patent rights identified during the development of the document will be in the Introduction and/or on the ISO list of patent declarations received (see www.iso.org/patents).

Any trade name used in this document is information given for the convenience of users and does not constitute an endorsement.

For an explanation of the voluntary nature of standards, the meaning of ISO specific terms and expressions related to conformity assessment, as well as information about ISO's adherence to the World Trade Organization (WTO) principles in the Technical Barriers to Trade (TBT), see www.iso.org/iso/foreword.html (standards.iteh.ai).

This document was prepared by Technical Committee ISO/TC 28, *Petroleum and related products, fuels and lubricants from natural or synthetic sources*.

This fourth edition cancels and replaces the third edition (ISO 2137:2007), which has been technically revised. The main changes compared to the previous edition are as follows:

- cleaning of cone and shaft assembly with solvent has been introduced to eliminate any drag forces;
- the precision table for repeatability and reproducibility for one-half-scale and one-quarter-scale has been revised to keep only an unconverted value.

Any feedback or questions on this document should be directed to the user's national standards body. A complete listing of these bodies can be found at www.iso.org/members.html.

Introduction

ISO 2137 was first published in 1972. A second edition was issued in 1985. The third revision was mainly on the dimensional tolerances of the various cones, to better fit with what is available from laboratory equipment suppliers. This revision was necessary because of all the quality plans and data integrity programmes established by numerous laboratories to conform with the various ISO quality standards. In the third edition of ISO 2137, the dimensional tolerances were enlarged to allow most of the cones to fulfil the requirements.

Before adopting changes in the third revision, an interlaboratory study was performed with cones conforming to new requirements and demonstrated that the precision of the method was not altered by changing the tolerances. Tolerances were retained only on the characteristics where it was established that they have a direct impact on the penetration determination, i.e. tip angle, tip height, tip top thickness, tip base diameter, cone angle, total mass of cone plus movable attachments.

iTeh STANDARD PREVIEW (standards.iteh.ai)

[SIST ISO 2137:2021](https://standards.iteh.ai/catalog/standards/sist/c1aca5ba-dc52-47f9-93bd-93cbe9a73a7/sist-iso-2137-2021)

<https://standards.iteh.ai/catalog/standards/sist/c1aca5ba-dc52-47f9-93bd-93cbe9a73a7/sist-iso-2137-2021>

Petroleum products and lubricants — Determination of cone penetration of lubricating greases and petrolatum

WARNING — The use of this document can involve hazardous materials, operations and equipment. This document does not purport to address all of the safety problems associated with its use. It is the responsibility of users of this document to take appropriate measures to ensure the safety and health of personnel prior to the application of the standard, and to determine the applicability of any other restrictions for this purpose.

1 Scope

This document specifies several methods for the empirical estimation of the consistency of lubricating greases and petrolatum by measuring the penetration of a standardized cone.

2 Normative references

The following documents are referred to in the text in such a way that some or all of their content constitutes requirements of this document. For dated references, only the edition cited applies. For undated references, the latest edition of the referenced document (including any amendments) applies.

ISO 23572, *Petroleum products — Lubricating greases — Sampling of greases*

3 Terms and definitions

For the purposes of this document, the following terms and definitions apply.

ISO and IEC maintain terminological databases for use in standardization at the following addresses:

- ISO Online browsing platform: available at <https://www.iso.org/obp>
- IEC Electropedia: available at <http://www.electropedia.org/>

3.1

penetration

depth that a standard object, cone or needle penetrates into a test portion under standardized conditions of time, temperature, load, etc

[SOURCE: ISO 1998-2:1998, 2.80.001 — modified: the Note has been deleted.]

3.2

cone penetration

distance that a standardized cone penetrates into a test portion under standardized conditions of load, time and temperature

Note 1 to entry: The cone penetration is expressed in units of 0,1 mm.

3.3

working

shearing action of a grease worker

3.4

unworked penetration

cone penetration (3.2) of a test portion that has received only minimum disturbance in transfer from the sample container to the cup of the grease worker

ISO 2137:2020(E)

3.5

worked penetration

cone penetration (3.2) of a test portion after it has been subjected to a defined number of strokes in a grease worker

3.6

prolonged worked penetration

cone penetration (3.2) of a test portion which has been worked more than the defined number of strokes in *worked penetration* (3.5)

3.7

block penetration

cone penetration (3.2) determined on a test portion which is sufficiently hard to hold its shape without a container

4 Principle

The cone penetration of lubricating grease is determined at 25 °C by releasing the cone assembly from the penetrometer and allowing the cone to drop for 5 s, and measuring the extent of the penetration. Three determinations shall be made and the average shall be reported as a result.

Unworked penetrations are determined on test portions transferred with a minimum of disturbance to a container suitable for test purposes.

Worked penetrations are determined immediately after working the test portion for 60 double strokes in a standard grease worker.

Prolonged worked penetrations are determined on test portions worked more than 60 double strokes.

Block penetrations are determined on a freshly prepared face of a cube cut from a block of grease with a standard cutter.

The cone penetration of petrolatum is determined by first melting and cooling a test sample under specified conditions and then measuring the penetration as for lubricating grease.

5 Classifications, procedures and limitation

The National Lubricating Grease Institute (NLGI) classifies greases according to their consistency, as measured by the 60 strokes worked penetration. The NLGI classification includes nine consistency numbers or grades, each grade corresponding to a given range of worked penetration. The NLGI classification is given in ISO 6743-99 and ISO 12924.

[Clause 8](#) specifies four procedures for determining the consistency of lubricating greases by measuring the penetration of a full-scale cone. These procedures cover the measurement of unworked, worked, prolonged worked and block penetrations. Penetrations up to 500 units can be measured.

[Clause 9](#) specifies methods for determining the consistency of lubricating greases when only small samples are available, by the use of cones a one-half-scale or one-quarter-scale of that used in [Clause 8](#). The methods are applicable to greases having penetrations of 175 units to 385 units with the full-scale cone and are intended for use only if the size of the test sample prevents the use of cones described in [Clause 8](#). They are not intended to replace the full-scale penetration as described in [Clause 8](#), although a conversion to full-scale penetration is given in [10.2](#). See [9.1](#) for the limitations on the use of one-quarter-scale cones due to the poor precision.

NOTE 1 Unworked penetrations do not generally represent the consistency of greases in use as effectively as do worked penetrations. The latter are usually preferred for inspecting lubricating greases.

NOTE 2 Penetration of block greases can be obtained on those products that are sufficiently hard to hold their shape. These greases generally have penetrations below 85 units.

[Clause 10](#) specifies a method for the determination of the consistency of petrolatum by measurement of the penetration of a full-scale cone, having penetrations up to 300 units. This method can also be used to estimate the consistency of slack waxes.

6 Apparatus

6.1 Penetrometer, similar to that shown in [Figure 1](#), capable of measuring, in tenths of a millimetre, the penetration of a cone in a test material.

[Figure 1](#) shows a combined assembly; generally, it is allowed to displace vertically either the cone assembly or the plate.

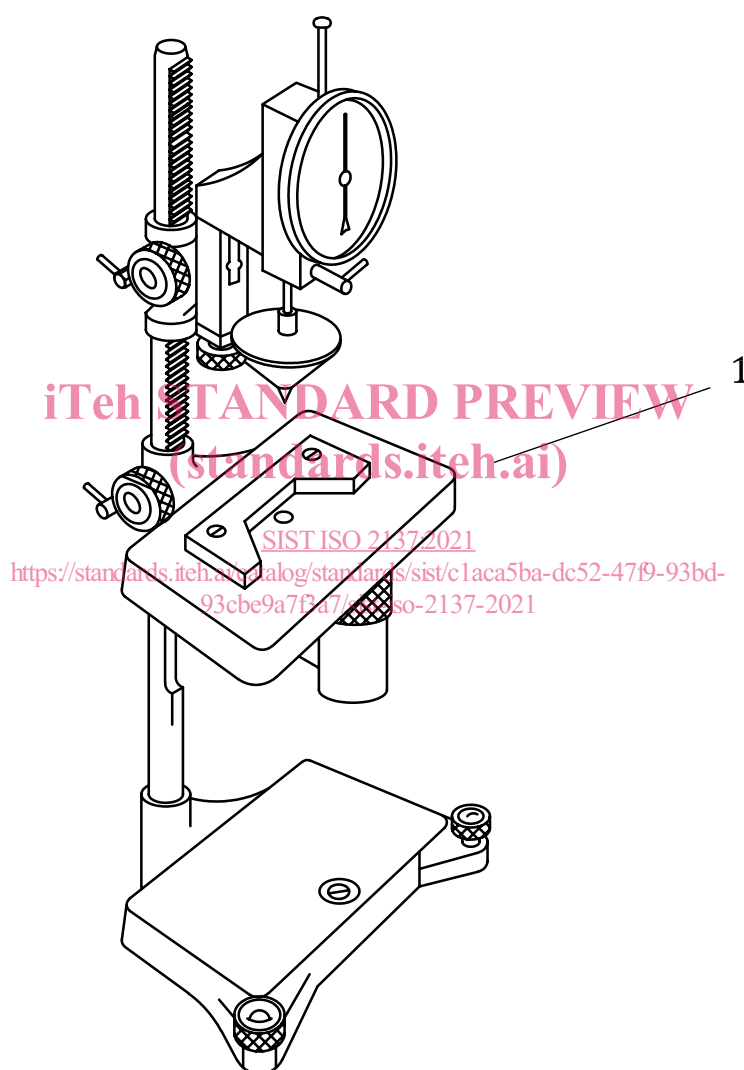

Key

1 centring device

Figure 1 — Penetrometer

The cone assembly or the table of the penetrometer shall be adjustable to enable accurate placement of the tip of the cone on the level surface of the material while maintaining a “zero” reading on the indicator. The cone shall fall, when released, without appreciable friction for at least 62 mm. The tip of the cone shall not hit the bottom of the sample container. The instrument shall be provided with level jigs screws and a spirit level to maintain the cone shaft in a vertical position.

ISO 2137:2020(E)

The measurement of the penetration depth may be performed using either mechanical devices (mechanical indicator) or electronic devices (digital indicator).

6.2 Cones

6.2.1 Full-scale cone, consisting of a conical body of magnesium or other suitable material with a detachable, hardened steel tip.

Dimensions and tolerances shall be as shown in [Figure 2](#). The total mass of the cone shall be $102,50 \text{ g} \pm 0,05 \text{ g}$ and the total mass of its movable attachments shall be $47,50 \text{ g} \pm 0,05 \text{ g}$. The attachments consist of a rigid shaft having a stop at its upper end and a suitable means at its lower end for engaging the cone. The interior construction may be modified to achieve the specified mass, provided that the general contour and mass distribution are not altered. The outer surface shall be polished to a very smooth finish.

For penetrations up to 400 units, the optional cone as shown in [Figure 3](#) may be used. For this cone the total mass shall be $102,50 \text{ g} \pm 0,05 \text{ g}$, and the total mass of movable attachments shall be $47,50 \text{ g} \pm 0,05 \text{ g}$.

6.2.2 One-half-scale cone and shaft, made of steel, stainless steel or brass with a hardened steel tip of 45 Rockwell C hardness to 50 Rockwell C hardness and constructed to conform to the dimensions and tolerances shown in [Figure 4](#).

The shaft may be made of stainless steel. The total mass of the cone and its movable attachments shall be $37,50 \text{ g} \pm 0,05 \text{ g}$. The mass of the cone shall be $22,500 \text{ g} \pm 0,025 \text{ g}$. The mass of the movable attachments shall be $15,000 \text{ g} \pm 0,025 \text{ g}$.

6.2.3 One-quarter-scale cone and shaft, consisting of a conical body of plastics or other low-density material with a hardened steel tip of 45 Rockwell C hardness to 50 Rockwell C hardness, and constructed to conform to the dimensions and tolerances shown in [Figure 5](#).

The shaft may be constructed of magnesium alloy. The total mass of the cone and its movable attachments shall be $9,380 \text{ g} \pm 0,025 \text{ g}$. The total mass of the cone and its movable attachments may be adjusted by adding small a shot to the cavity of the shaft.