**Dentistry — Endodontic
instruments —**

**Part 3:
Compactors**

Médecine bucco-dentaire — Instruments d'endodontie —

Partie 3: Compacteurs
iTeh STANDARD PREVIEW
(standards.iteh.ai)

ISO 3630-3:2021

<https://standards.iteh.ai/catalog/standards/sist/d61b6073-5c8e-4152-b620-83d937ee16c0/iso-3630-3-2021>



iTeh STANDARD PREVIEW (standards.iteh.ai)

ISO 3630-3:2021

<https://standards.iteh.ai/catalog/standards/sist/d61b6073-5c8e-4152-b620-83d937ee16c0/iso-3630-3-2021>



COPYRIGHT PROTECTED DOCUMENT

© ISO 2021

All rights reserved. Unless otherwise specified, or required in the context of its implementation, no part of this publication may be reproduced or utilized otherwise in any form or by any means, electronic or mechanical, including photocopying, or posting on the internet or an intranet, without prior written permission. Permission can be requested from either ISO at the address below or ISO's member body in the country of the requester.

ISO copyright office
CP 401 • Ch. de Blandonnet 8
CH-1214 Vernier, Geneva
Phone: +41 22 749 01 11
Email: copyright@iso.org
Website: www.iso.org

Published in Switzerland

Contents

	Page
Foreword	iv
1 Scope	1
2 Normative references	1
3 Terms and definitions	1
4 Classifications and symbols	2
4.1 Classifications	2
4.2 Symbols	2
5 Requirements	3
5.1 Material	3
5.2 Dimensional requirements	3
5.2.1 General	3
5.2.2 Diameter	3
5.2.3 Length	3
5.2.4 Tip	3
5.2.5 Shaft	4
5.2.6 Binangle compactor	5
5.3 Mechanical requirements	6
5.3.1 Stiffness (resistance to bending), finger compactors	6
5.3.2 Stiffness (resistance to bending), binangle compactors	6
5.3.3 Stiffness (resistance to bending), heat-carriers	6
5.3.4 Handle security	7
5.3.5 Surface finish	7
5.4 Resistance to reprocessing	7
5.5 Colour-coding	7
6 Sampling	7
7 Testing	7
7.1 General	7
7.2 Size	7
7.3 Stiffness (resistance to bending), finger compactors	8
7.4 Stiffness (resistance to bending), binangle compactors	8
7.5 Stiffness (resistance to bending), heat-carriers	9
7.6 Handle security	10
8 Designation, marking, and identification	10
9 Packaging	10
10 Instructions for use	10
11 Labelling	10
Bibliography	11

Foreword

ISO (the International Organization for Standardization) is a worldwide federation of national standards bodies (ISO member bodies). The work of preparing International Standards is normally carried out through ISO technical committees. Each member body interested in a subject for which a technical committee has been established has the right to be represented on that committee. International organizations, governmental and non-governmental, in liaison with ISO, also take part in the work. ISO collaborates closely with the International Electrotechnical Commission (IEC) on all matters of electrotechnical standardization.

The procedures used to develop this document and those intended for its further maintenance are described in the ISO/IEC Directives, Part 1. In particular, the different approval criteria needed for the different types of ISO documents should be noted. This document was drafted in accordance with the editorial rules of the ISO/IEC Directives, Part 2 (see www.iso.org/directives).

Attention is drawn to the possibility that some of the elements of this document may be the subject of patent rights. ISO shall not be held responsible for identifying any or all such patent rights. Details of any patent rights identified during the development of the document will be in the Introduction and/or on the ISO list of patent declarations received (see www.iso.org/patents).

Any trade name used in this document is information given for the convenience of users and does not constitute an endorsement.

For an explanation of the voluntary nature of standards, the meaning of ISO specific terms and expressions related to conformity assessment, as well as information about ISO's adherence to the World Trade Organization (WTO) principles in the Technical Barriers to Trade (TBT) see www.iso.org/iso/foreword.html.

This document was prepared by Technical Committee ISO/TC 106, *Dentistry*, Subcommittee SC 4, *Dental instruments*, in collaboration with the European Committee for Standardization (CEN) Technical Committee CEN/TC 55, *Dentistry*, in accordance with the Agreement on technical cooperation between ISO and CEN (Vienna Agreement).

This third edition cancels and replaces the second edition (ISO 3630-3:2015), which has been technically revised.

The main changes compared to the previous editions are as follows:

- the symbols D , d_3 and d_{16} in this document have been harmonized with the other parts of the ISO 3630 series;
- 'types' has been changed to 'classes';
- test methods have been improved.

A list of all parts in the ISO 3630 series can be found on the ISO website.

Any feedback or questions on this document should be directed to the user's national standards body. A complete listing of these bodies can be found at www.iso.org/members.html.

Dentistry — Endodontic instruments —

Part 3: Compactors

1 Scope

This document specifies the requirements and test methods for endodontic compactors (pluggers and spreaders) which are used for the compaction of endodontic filling materials, and also heat-carriers (which are not specified in the other parts of the ISO 3630 series).

This document specifies the requirements for size, marking, product designation, safety considerations, and their labelling and packaging.

2 Normative references

The following documents are referred to in the text in such a way that some or all of their content constitutes requirements of this document. For dated references, only the edition cited applies. For undated references, the latest edition of the referenced document (including any amendments) applies.

ISO 1942, *Dentistry — Vocabulary*

ISO 3630-1:2019, *Dentistry — Endodontic instruments — Part 1: General requirements*

ISO 3630-3:2021

3 Terms and definitions

<https://standards.iteh.ai/catalog/standards/sist/d61b6073-5c8e-4152-b620-83d937ee16c0/iso-3630-3-2021>

For the purposes of this document, the terms and definitions given in ISO 1942, ISO 3630-1, and the following apply.

ISO and IEC maintain terminological databases for use in standardization at the following addresses:

- ISO Online browsing platform: available at <https://www.iso.org/obp>
- IEC Electropedia: available at <http://www.electropedia.org/>

3.1

compactor

endodontic instrument used manually as a *plugger* (3.2) or *spreader* (3.3) designed to compact filling materials in the root canal system

Note 1 to entry: There are two types: finger (hand) and binangle.

3.2

plugger

compactor (3.1), used mainly in an apical direction, whose *working surface* (3.7) is tapered or non-tapered, circular in cross-section and has a flat tip

Note 1 to entry: [Figure 1](#) and [Table 1](#) describe the specific dimensions and characteristics of a plugger.

**3.3
spreader**

compactor (3.1), used mainly in a lateral direction, whose *working surface* (3.7) is tapered, circular in cross-section and has a pointed tip

Note 1 to entry: [Figure 2](#) and [Table 2](#) describe the specific dimensions and characteristics of a spreader.

**3.4
binangle compactor**

angled *plugger* (3.2) or *spreader* (3.3) used by hand for obturation of the root canal system

Note 1 to entry: [Figure 3](#) and [Table 3](#) illustrate the characteristics of a binangle compactor.

**3.5
heat-carrier**

instrument used for transferring heat to the filling material in the root canal system

**3.6
thermomechanical compactor**

instrument that generates heat by its rotation for compacting obturation material in the root canal system

**3.7
working surface**

part of a *compactor* (3.1) that contacts obturation material

iTech STANDARD PREVIEW
(standards.iteh.ai)

4 Classifications and symbols

4.1 Classifications

ISO 3630-3:2021

For the purposes of this document, endodontic compactors are grouped as Class 1, Class 2, and Class 3 instruments as specified in ISO 3630-1.

The definitions in [Clause 3](#) specify the classification of endodontic pluggers and spreaders which can be used in a lateral or apical direction, or as heat carriers or thermomechanical compactors.

4.2 Symbols

For the purposes of this document, the following symbols apply.

- D diameter of the projection of the working part (surface) at the tip end (reference size)
- d_n diameter of the compactor at the subscripted millimetre distance from the tip indicated by (n)
EXAMPLE 1 d_3 is the diameter at 3 mm from the tip.
- l_n length of the compactor at the subscripted millimetre distance from the tip indicated by (n)
EXAMPLE 2 l_3 is the length 3 mm away from the tip.
- l_{op} length of operative part (surface), measured from the tip
- l_w length of the working part (surface), measured from the tip

5 Requirements

5.1 Material

The operative part and the handle, if one piece, shall be made of any material which allows the instruments to meet the requirements in ISO 3630-1:2019, 5.7.

5.2 Dimensional requirements

5.2.1 General

The nominal diameter of pluggers and spreaders, when stated, shall meet the requirements of [Tables 1](#) and [2](#), respectively.

Within the dimensional requirements, variations in shape and design are at the manufacturer's discretion.

With the exception of Class 1 compactors, working surface length, operative part length, and overall length are left at the discretion of the manufacturer.

5.2.2 Diameter

The diameter designated as D for Class 1, Class 2, and Class 3 compactors is the reference for the nominal size of the compactor, as shown in [Figures 1](#) and [2](#). Measure the diameter in accordance with ISO 3630-1:2019, 7.3.

All other dimensions identified in the figures or tables of ISO 3630-1:2019 are used for the purpose of calculation of the taper for the working surface of Class 2 compactors, the calculation for D , and for determination of compactor diameter test locations.

5.2.3 Length

5.2.3.1 General

The length of the operative part and overall length are left at the discretion of the manufacturer.

Measure the length in accordance with ISO 3630-1:2019, 7.3.

5.2.3.2 Class 1 (standard) compactors

The length of the working surface shall be a minimum of 16 mm.

The length shall be within 0,5 mm of the length specified by the manufacturer.

The length of the operative part and overall length shall be left at the discretion of the manufacturer.

5.2.3.3 Class 2 (taper) and Class 3 (non-taper) compactors

The manufacturer shall specify a minimum length for the working surface.

The operative part length shall be within 0,5 mm of the length specified.

5.2.4 Tip

The tip of the plugger ([Figure 1](#)) shall be flat and perpendicular to the axis of the compactor.

The tip of the spreader ([Figure 2](#)) may be pointed or rounded and left at the discretion of the manufacturer.

5.2.5 Shaft

The shaft shall be either cylindrical or tapered. For Class 3 compactors, the diameter D shall not exceed d_3 .

Dimensions in millimetres

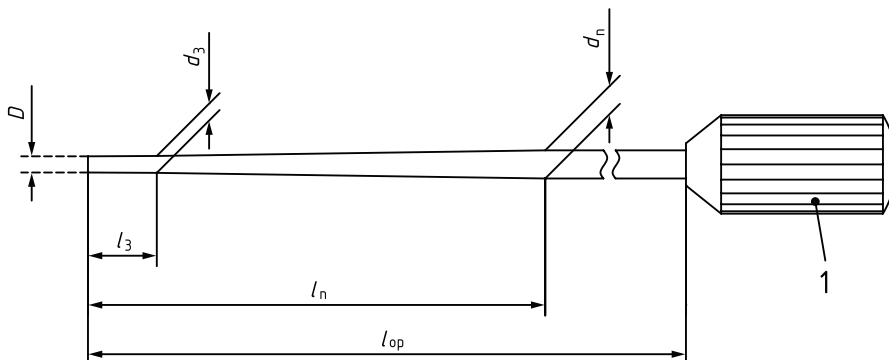

Key

1 handle

Figure 1 — Plugger

Table 1 — Diameters and designation of pluggers (Class 1)

Dimension in millimetres

Nominal size	D $\pm 0,02$	d_3 $\pm 0,02$	d_{16} $\pm 0,02$	Colour designation
15	0,15	0,21	0,47	white
20	0,20	0,26	0,52	yellow
25	0,25	0,31	0,57	red
30	0,30	0,36	0,62	blue
35	0,35	0,41	0,67	green
40	0,40	0,46	0,72	black
45	0,45	0,51	0,77	white
50	0,50	0,57	0,82	yellow
55	0,55	0,61	0,87	red
60	0,60	0,66	0,92	blue
70	0,70	0,76	1,02	green
80	0,80	0,86	1,12	black
90	0,90	0,96	1,22	white
100	1,00	1,06	1,32	yellow
110	1,10	1,16	1,42	red
120	1,20	1,26	1,52	blue
130	1,30	1,36	1,62	green
140	1,40	1,46	1,72	black

Dimensions in millimetres

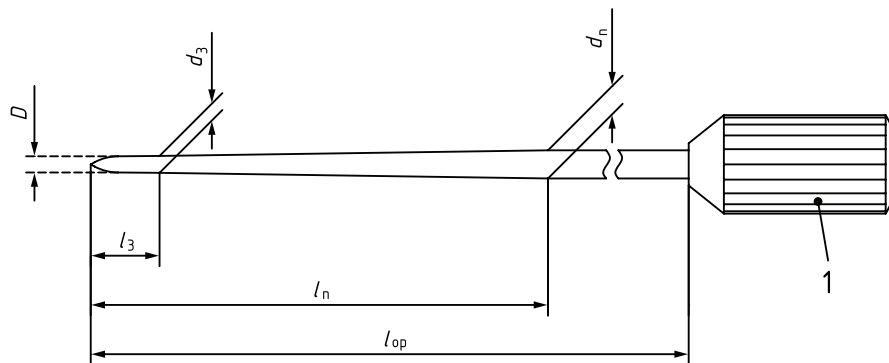

Key

1 handle

Figure 2 — Spreader

Table 2 — Diameters and designations of spreaders (Class 2)

Dimension in millimetres

Nominal size	D	d_3	d_{16}	Colour designation
010	0,10	$\pm 0,02$ 0,16	$\pm 0,02$ 0,42	purple
015	0,15	0,21	0,47	white
020	0,20	0,26	0,52	yellow
025	0,25	0,31	0,57	red
030	0,30	0,36	0,62	blue
035	0,35	0,41	0,67	green
040	0,40	0,46	0,72	black
045	0,45	0,51	0,77	white

5.2.6 Binangle compactor

The dimensions and characteristics of the binangle compactor are shown in [Figure 3](#) and [Table 3](#).

At the discretion of the manufacturer, a Class 1 compactor may have a working surface length as shown in [Figure 3](#) (l_w) different from 16 mm.

The angle, α , shown in [Figure 3](#) shall be within the tolerance as specified in [Table 3](#) for any specific size within a brand.

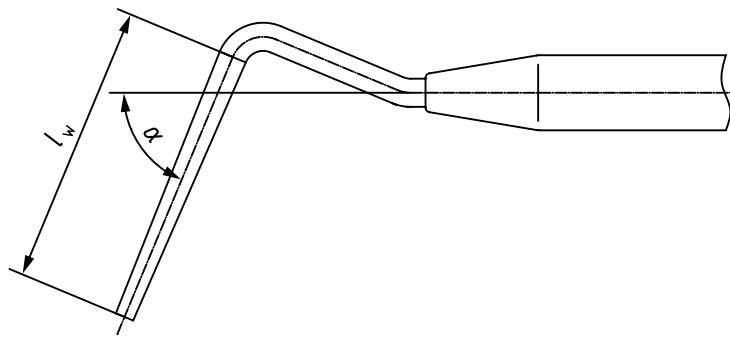

Figure 3 — Binangle compactor

Table 3 — Angle tolerance

Angle range α	Tolerance
$\alpha \leq 10^\circ$	± 1
$10^\circ < \alpha \leq 25^\circ$	± 2
$25^\circ < \alpha \leq 45^\circ$	± 3
$\alpha > 45^\circ$	± 4

5.3 Mechanical requirements (standards.iteh.ai)

5.3.1 Stiffness (resistance to bending), finger compactors

Test one instrument: after a deflection of 7°, the handle shall return to its original position on removal of the force; then, after a deflection of 9°, it shall return to within 2° of its original position; then, after a deflection of 18°, there shall be no sign of failure.

If the instrument complies with each degree of deflection specified, and there is no sign of failure, it passes.

Test in accordance with Clause 6 and 7.3.

5.3.2 Stiffness (resistance to bending), binangle compactors

Test one instrument. After a deflection of 15 mm, the handle shall return to its original position on removal of the force; then, after a deflection of 20 mm, it shall return to within 4,5 mm of its original position; then, after a deflection of 40 mm, there shall be no sign of failure.

If the instrument complies with each degree of deflection specified, and there is no sign of failure, it passes.

Test in accordance with Clause 6 and 7.4.

5.3.3 Stiffness (resistance to bending), heat-carriers

Test one instrument: after a deflection of 15 mm, the handle shall return to its original position on removal of the force; then, after a deflection of 20 mm, it shall return to within 4,5 mm of its original position, then, after a deflection of 40 mm, there shall be no sign of failure.

If the instrument complies with each degree of deflection specified, and there is no sign of failure, it passes.