

ISO/TC 83

Secretariat: DIN

Voting begins on:  
2020-04-30

Voting terminates on:  
2020-06-25

---

---

## Stationary training equipment —

### Part 7:

## Rowing equipment, additional specific safety requirements and test methods

*Équipement d'entraînement fixe —*

*Partie 7: Rameurs, exigences spécifiques de sécurité et méthodes d'essai supplémentaires*

*Standard PREVIEW*  
*(standard no. 20957-7)*  
*Full standard available at*  
*https://standards.iteh.ai/catalog/standards/iso-fdis/20957-7*  
*c228-44c2-b414-72329569ccc/iso-fdis/20957-7*

RECIPIENTS OF THIS DRAFT ARE INVITED TO SUBMIT, WITH THEIR COMMENTS, NOTIFICATION OF ANY RELEVANT PATENT RIGHTS OF WHICH THEY ARE AWARE AND TO PROVIDE SUPPORTING DOCUMENTATION.

IN ADDITION TO THEIR EVALUATION AS BEING ACCEPTABLE FOR INDUSTRIAL, TECHNOLOGICAL, COMMERCIAL AND USER PURPOSES, DRAFT INTERNATIONAL STANDARDS MAY ON OCCASION HAVE TO BE CONSIDERED IN THE LIGHT OF THEIR POTENTIAL TO BECOME STANDARDS TO WHICH REFERENCE MAY BE MADE IN NATIONAL REGULATIONS.

**ISO/CEN PARALLEL PROCESSING**



Reference number  
ISO/FDIS 20957-7:2020(E)

**iTeh STANDARD PREVIEW**  
(standards.iteh.ai)  
Full standard:  
<https://standards.iteh.ai/catalog/standards/sist/0736da77-c228-44c2-b414-72329569ccc/iso-fdis-20957-7>



**COPYRIGHT PROTECTED DOCUMENT**

© ISO 2020

All rights reserved. Unless otherwise specified, or required in the context of its implementation, no part of this publication may be reproduced or utilized otherwise in any form or by any means, electronic or mechanical, including photocopying, or posting on the internet or an intranet, without prior written permission. Permission can be requested from either ISO at the address below or ISO's member body in the country of the requester.

ISO copyright office  
CP 401 • Ch. de Blandonnet 8  
CH-1214 Vernier, Geneva  
Phone: +41 22 749 01 11  
Fax: +41 22 749 09 47  
Email: [copyright@iso.org](mailto:copyright@iso.org)  
Website: [www.iso.org](http://www.iso.org)

Published in Switzerland

# Contents

Page

<b>Foreword</b> .....	<b>iv</b>
<b>1 Scope</b> .....	<b>1</b>
<b>2 Normative references</b> .....	<b>1</b>
<b>3 Terms and definitions</b> .....	<b>1</b>
<b>4 Classification</b> .....	<b>3</b>
<b>5 Safety requirements</b> .....	<b>3</b>
5.1 General.....	3
5.2 External construction.....	3
5.2.1 Squeeze, shear and reciprocating points within the accessible area.....	3
5.2.2 Transmission elements and rotating parts.....	3
5.2.3 Temperature rise of accessible surfaces.....	4
5.2.4 Seat.....	4
5.3 Intrinsic loading.....	4
5.4 Handles.....	4
5.5 Load of ropes, belts, chains and their attachment components.....	4
5.6 Foot strap.....	4
5.7 Foot support.....	4
5.8 Endurance.....	5
5.9 Stability.....	5
5.10 Additional requirements for class A.....	5
5.11 Additional instructions for use.....	5
<b>6 Test methods</b> .....	<b>5</b>
6.1 General.....	5
6.1.1 Dimensional check.....	5
6.1.2 Visual examination.....	5
6.1.3 Tactile examination.....	5
6.1.4 Performance test.....	5
6.1.5 Weighing test.....	6
6.1.6 Load test of ropes, belts, chains and attachment components.....	6
6.2 Testing of seat.....	6
6.3 Testing of temperature rise.....	6
6.4 Testing of intrinsic loading.....	6
6.5 Testing of foot strap.....	6
6.6 Testing of foot support.....	6
6.7 Endurance testing.....	7
6.8 Testing of stability.....	7
6.9 Testing of additional requirements for class A.....	7
6.9.1 General.....	7
6.9.2 Speed-independent rowing equipment.....	8
6.9.3 Speed-dependent rowing equipment.....	8
<b>7 Test report</b> .....	<b>9</b>

## Foreword

ISO (the International Organization for Standardization) is a worldwide federation of national standards bodies (ISO member bodies). The work of preparing International Standards is normally carried out through ISO technical committees. Each member body interested in a subject for which a technical committee has been established has the right to be represented on that committee. International organizations, governmental and non-governmental, in liaison with ISO, also take part in the work. ISO collaborates closely with the International Electrotechnical Commission (IEC) on all matters of electrotechnical standardization.

The procedures used to develop this document and those intended for its further maintenance are described in the ISO/IEC Directives, Part 1. In particular, the different approval criteria needed for the different types of ISO documents should be noted. This document was drafted in accordance with the editorial rules of the ISO/IEC Directives, Part 2 (see [www.iso.org/directives](http://www.iso.org/directives)).

Attention is drawn to the possibility that some of the elements of this document may be the subject of patent rights. ISO shall not be held responsible for identifying any or all such patent rights. Details of any patent rights identified during the development of the document will be in the Introduction and/or on the ISO list of patent declarations received (see [www.iso.org/patents](http://www.iso.org/patents)).

Any trade name used in this document is information given for the convenience of users and does not constitute an endorsement.

For an explanation of the voluntary nature of standards, the meaning of ISO specific terms and expressions related to conformity assessment, as well as information about ISO's adherence to the World Trade Organization (WTO) principles in the Technical Barriers to Trade (TBT) see [www.iso.org/iso/foreword.html](http://www.iso.org/iso/foreword.html).

This document was prepared by Technical Committee ISO/TC 83, *Sports and other recreational facilities and equipment*, in collaboration with the European Committee for Standardization (CEN) Technical Committee CEN/TC 136, Sports, playground and other recreational facilities and equipment, in accordance with the Agreement on technical cooperation between ISO and CEN (Vienna Agreement).

This second edition cancels and replaces the first edition (ISO 20957-7:2005), which has been technically revised.

The main changes compared to the previous edition are as follows:

- the formulation has been aligned with ISO 20957-1;
- explanations have been added to [6.1](#);
- requirements on display/power accuracy testing have been added to [6.9](#);
- [Clause 7](#) has been added;

A list of all parts in the ISO 20957 series can be found on the ISO website.

Any feedback or questions on this document should be directed to the user's national standards body. A complete listing of these bodies can be found at [www.iso.org/members.html](http://www.iso.org/members.html).

# Stationary training equipment —

## Part 7:

# Rowing equipment, additional specific safety requirements and test methods

## 1 Scope

This document specifies safety requirements for rowing equipment.

This document is intended to be read in conjunction with the general safety requirements of ISO 20957-1.

This document is applicable to rowing type stationary training equipment, hereinafter referred to as rowing equipment, within the classes H, S and I and classes A, B and C regarding accuracy.

## 2 Normative references

The following documents are referred to in the text in such a way that some or all of their content constitutes requirements of this document. For dated references, only the edition cited applies. For undated references, the latest edition of the referenced document (including any amendments) applies.

ISO 20957-1, *Stationary training equipment — Part 1: General safety requirements and test methods*

## 3 Terms and definitions

For the purposes of this document, the terms and definitions given in ISO 20957-1 and the following apply.

ISO and IEC maintain terminological databases for use in standardization at the following addresses:

- ISO Online browsing platform: available at <https://www.iso.org/obp>
- IEC Electropedia: available at <http://www.electropedia.org/>

### 3.1

#### rowing equipment

stationary training equipment with a moving seat simulating a rowing-like motion

Note 1 to entry: See [Figures 1](#) and [2](#).

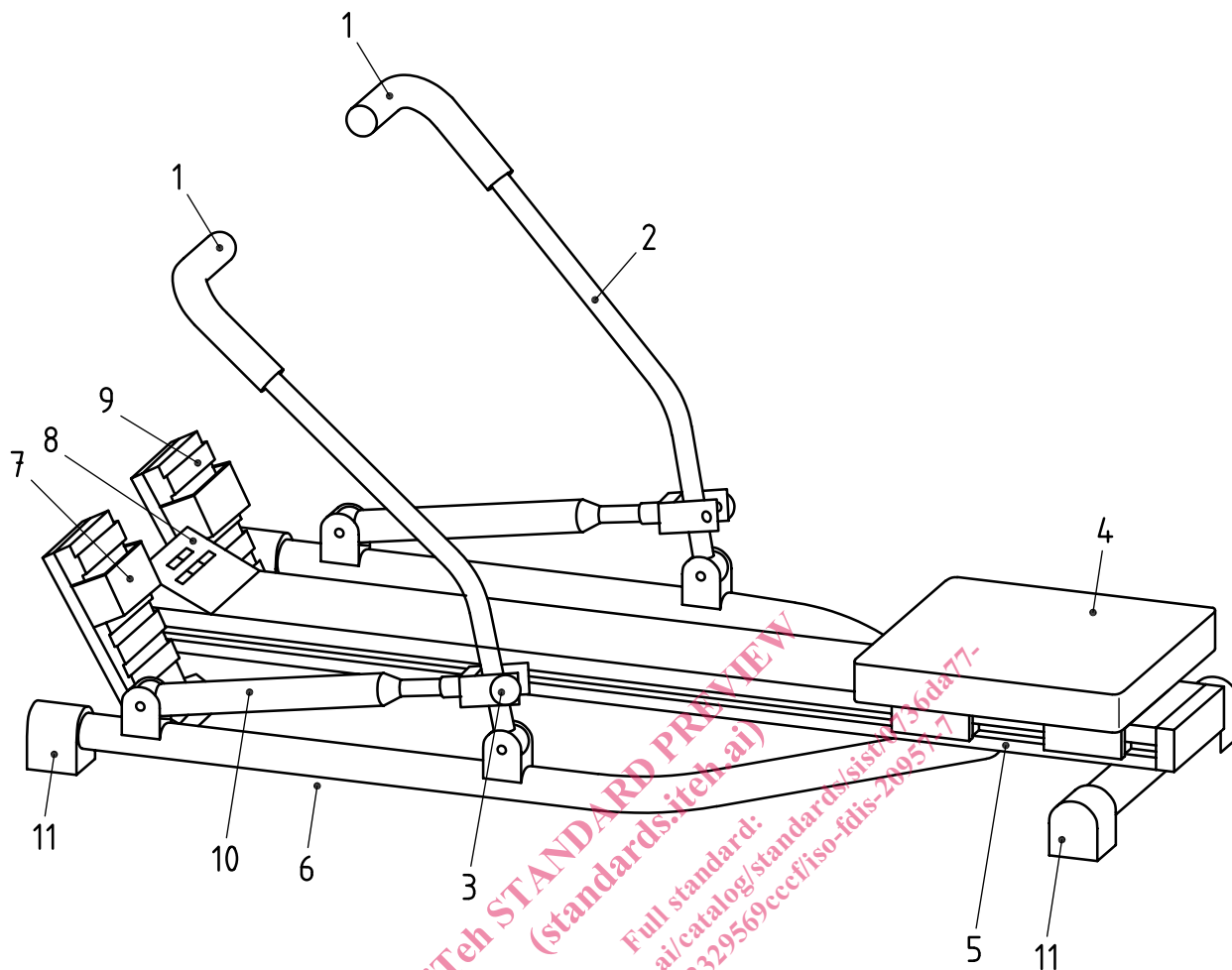

**Key**

- |   |                       |    |                            |
|---|-----------------------|----|----------------------------|
| 1 | hand grip             | 7  | foot-strap                 |
| 2 | arm                   | 8  | display                    |
| 3 | resistance adjustment | 9  | foot support               |
| 4 | seat                  | 10 | hydraulic/pneumatic piston |
| 5 | rail                  | 11 | base support               |
| 6 | frame                 |    |                            |

**Figure 1 — Example of rowing equipment with hydraulic/pneumatic system**

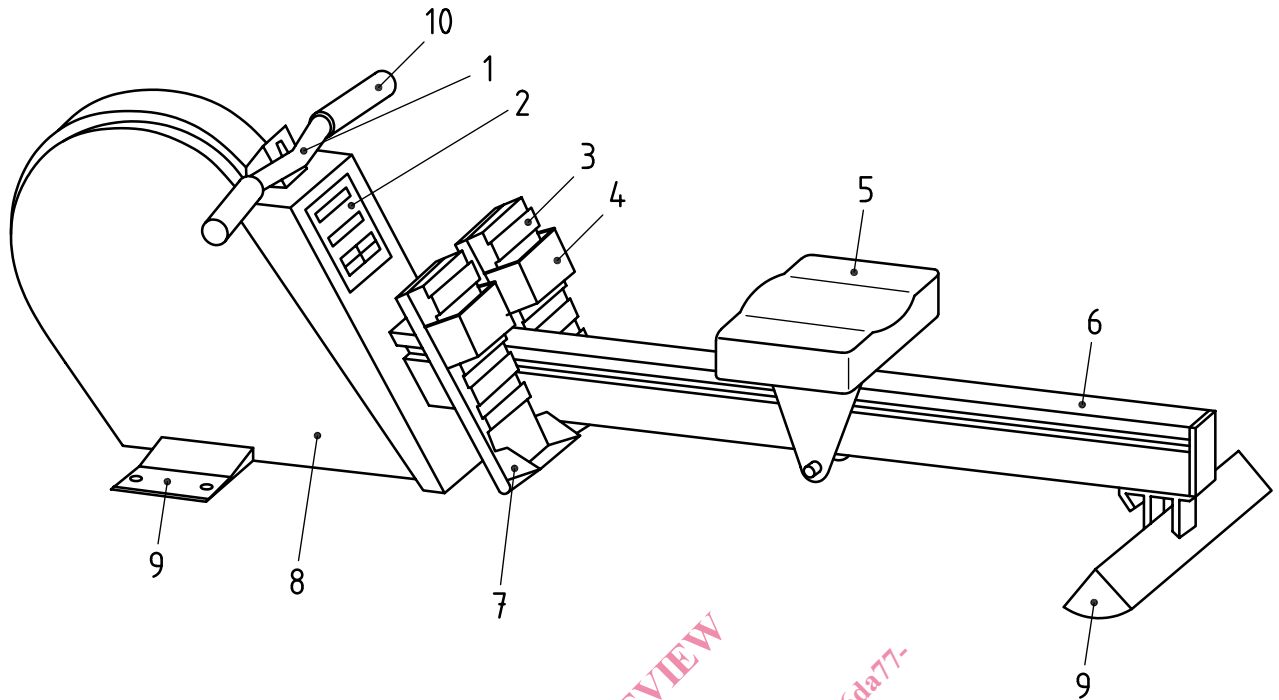
**Key**

- |   |              |    |              |
|---|--------------|----|--------------|
| 1 | handle       | 6  | rail         |
| 2 | display      | 7  | heel support |
| 3 | foot support | 8  | housing      |
| 4 | foot-strap   | 9  | base support |
| 5 | seat         | 10 | hand grip    |

**Figure 2 — Example of rowing equipment with cable system**

## 4 Classification

The classification given in ISO 20957-1 shall apply.

## 5 Safety requirements

### 5.1 General

Depending on the design of the piece of equipment, the following requirements shall apply, as appropriate.

### 5.2 External construction

#### 5.2.1 Squeeze, shear and reciprocating points within the accessible area

The squeeze, shear and reciprocating points within the accessible area shall be in accordance with ISO 20957-1.

#### 5.2.2 Transmission elements and rotating parts

Transmission elements, fans and flywheels shall be in accordance with ISO 20957-1.

### 5.2.3 Temperature rise of accessible surfaces

Accessible surfaces of the rowing equipment shall have a temperature of  $\leq 65$  °C.

Test in accordance with [6.3](#).

### 5.2.4 Seat

The seat shall not derail when a load of  $\geq 100$  N is applied to the seat in all directions.

Test in accordance with [6.2](#).

## 5.3 Intrinsic loading

The rowing equipment shall withstand a load of 2,5 times the maximum user's body mass  $\pm 5$  % as specified by the manufacturer or 2 500 N, whichever is greater.

After the test, the rowing equipment shall not be broken and shall still function as intended by the manufacturer.

Test in accordance with [6.4](#).

## 5.4 Handles

In rowing equipment where the handle is connected to the rowing equipment by a flexible member (rope, belt or chain) the mass of the handle without a flexible member shall be  $\leq 600$  g.

The range of movement of the handle shall be more than 1 600 mm measured from the centre line of the foot rest to the centre of the handle.

Test in accordance with [6.1.5](#).

## 5.5 Load of ropes, belts, chains and their attachment components

Rowing equipment using ropes, belts, chains and attachment components (e. g. snap links, shackles, carabineers, clamps or similar) shall withstand a static load of six times  $(350 \pm 5)$  N.

Test in accordance with [6.1.6](#).

## 5.6 Foot strap

Provisions shall be made for fastening the foot (foot straps). For classes S and I, the foot support or foot strap shall be adjustable for different foot sizes.

Test in accordance with [6.1.4](#).

Each foot strap shall withstand a pull force of  $\geq 500$  N perpendicular to the foot support.

After the test, the rowing equipment shall not be broken and shall still function as intended by the manufacturer.

Test in accordance with [6.5](#).

## 5.7 Foot support

Each foot support shall withstand a push force of  $\geq 1\ 000$  N perpendicular to the foot support.

After the test, the training equipment shall not be broken and shall still function as intended by the manufacturer.

Test in accordance with [6.6](#).



## 5.8 Endurance

The rowing equipment shall withstand

- 12 000 cycles for class H, and
- 100 000 cycles for classes S and I,

while loaded with the maximum body weight specified by the manufacturer or 100 kg whichever is greater and with the maximum resistance applied.

After the test, the rowing equipment shall not be broken and shall still function as intended by the manufacturer.

Test in accordance with [6.7](#).

## 5.9 Stability

The rowing equipment shall not tip over.

Test in accordance with [6.8](#).

## 5.10 Additional requirements for class A

For values  $\geq 50$  W, the accuracy of the power display shall be within the tolerance of  $\pm 10$  % and for values of  $< 50$  W, the accuracy of the power display shall be within the tolerance of  $\pm 5$  W.

Test in accordance with [6.9](#).

## 5.11 Additional instructions for use

In addition to the general instructions for use according to ISO 20957-1, at least the following information shall be given, depending on the class:

- a) for class A, testing parameters: training speed, resistance setting and range of movement;
- b) handling and storage.

## 6 Test methods

### 6.1 General

#### 6.1.1 Dimensional check

The measurement shall be done with appropriate measurement devices.

#### 6.1.2 Visual examination

The visual examination shall be done under proper lighting.

#### 6.1.3 Tactile examination

The tactile examination shall be done without gloves.

#### 6.1.4 Performance test

The tested mechanism shall be actuated as intended by the manufacturer.