



Standard Test Methods for Bicycle Forks¹

This standard is issued under the fixed designation F2273; the number immediately following the designation indicates the year of original adoption or, in the case of revision, the year of last revision. A number in parentheses indicates the year of last reapproval. A superscript epsilon (ϵ) indicates an editorial change since the last revision or reapproval.

1. Scope

1.1 These test methods describe mechanical tests for determining the following performance properties:

- 1.1.1 Compression Load,
- 1.1.2 Bending Load,
- 1.1.3 Impact Resistance, and
- 1.1.4 Bending Fatigue Life (followed by Impact Resistance).

1.2 The values stated in SI units are to be regarded as standard.

1.3 *This standard does not purport to address all of the safety concerns, if any, associated with its use. It is the responsibility of the user of this standard to establish appropriate safety and health practices and determine the applicability of regulatory limitations prior to use.*

2. Referenced Documents

2.1 *ASTM Standards*:²

E4 Practices for Force Verification of Testing Machines
F2043 Classification for Bicycle Usage

3. Terminology

3.1 *Definitions of Terms Specific to This Standard*:

3.1.1 *bicycle fork (fork)*—the mechanism between the head tube and the front axle, including the steerer tube, crown(s), shock absorbers, lower tubes, and upper tubes.

3.1.2 *steer tube*—the structural fork component typically housed inside the bicycle head tube, connected to the fork crown. The steerer tube transmits steering inputs from the rider to the fork and connects the fork to the bicycle frame by means of headset bearings.

3.1.3 *fork crown(s), or crown(s)*—the primary structural fork component responsible for connecting the steerer tube to

the fork upper tube(s) or fork blades. Some suspension forks have an upper and a lower crown, while other forks have only one.

3.1.4 *dropout*—the fork component used to support the front wheel(s) at the axle(s).

3.1.5 *dropout centerline*—the front hub mounting axis that passes through both right and left dropouts.

3.1.6 *tire clearance*—the distance between the top surface of the tire and the bottom surface of the fork crown with no compressive force applied to the fork.

3.1.7 *crown-to-axle clearance*—the distance between the fork axle centerline and the bottom surface of the crown with no compressive load applied to the fork.

3.1.8 *head set*—the bearing cup, cones, and other supporting components for allowing rotation of the fork about the steering axis.

3.1.9 *limit trip or stop*—a deflection of the fork, which exceeds the allowable displacement values and causes the machine to stop running.

3.1.10 *suspension fork*—front fork incorporating compliance in the axial direction, parallel to the steer tube.

3.1.11 *rigid fork*—front fork that is not designed to be compliant in the axial direction.

4. Summary of Test Methods

4.1 *Compression Load Test*—In this test the fork is compressed in a direction parallel to the steerer tube. The distance from the bottom surface of the crown to the axle centerline is measured.

4.2 *Bending Load Test*—In this test the fork is restrained by the steerer tube and a load is applied in a direction perpendicular to the steerer tube axis, at the midpoint of the dropout centerline. The deflection is measured at the dropout centerline in a direction perpendicular to the steerer tube axis.

4.3 *Impact Resistance Test*—In this test a fork is fixtured with the steerer tube oriented horizontally, and supported by bearings. A weight is dropped from a prescribed height onto a fixture attached to the fork dropouts in line with the dropout centerline. Permanent deflection is measured at the dropout centerline in a direction perpendicular to the steerer tube axis. The ability of the connection between the steerer tube and

¹ These test methods are under the jurisdiction of ASTM Committee F08 on Sports Equipment, Playing Surfaces, and Facilities and is the direct responsibility of Subcommittee F08.10 on Bicycles.

Current edition approved March 1, 2011. Published June 2011. Originally approved in 2003. Last previous edition approved in 2003 as F2273 – 03. DOI: 10.1520/F2273-11.

² For referenced ASTM standards, visit the ASTM website, www.astm.org, or contact ASTM Customer Service at service@astm.org. For *Annual Book of ASTM Standards* volume information, refer to the standard's Document Summary page on the ASTM website.

crown to support torque applied about the axis of the steerer tube is also evaluated.

4.4 *Fatigue Plus Impact Test*—In this test a fork is restrained by the steerer tube and a fully reversed load is applied in a direction perpendicular to the steerer tube axis at the midpoint of the dropout centerline. The test is suspended and the sample inspected if displacements exceed a prescribed value, or after the specified number of cycles, whichever comes first. If the test sample reaches the target cycle count, it is subsequently subjected to a frontal impact as described in 4.3. If inspection of the sample reveals a structural crack or fracture before reaching the target cycle count, or if the specified displacements during the cyclic loading are exceeded, the test is concluded and the number of cycles reached before failure is recorded.

5. Significance and Use

5.1 These tests are used to determine the conformance of a bicycle fork sample to a standard specified for each use classification.

6. Apparatus

6.1 *Compression Load Test:*

6.1.1 A fixture similar to Fig. 1 is required.

6.1.2 The load shall be applied to the top of the crown and along the centerline of the steerer tube (Fig. 1).

6.1.3 If necessary, either a roller or linkage system shall be used to allow translation of the dropouts while the fork is compressed.

6.1.4 The distance from the dropout centerline to the nearest surface of the crown on steerer tube centerline shall be measured (Fig. 1).

6.2 *Bending Load Test:*

6.2.1 A fixture similar to that shown in Fig. 2 is required to position a fork such that the steerer tube axis is horizontal and such that the fork is restrained by the steerer tube using standard headset bearings.

6.2.2 Bearing separation shall be 150 mm as shown in Fig. 2. Forks that require bearing installation not consistent with Fig. 2 shall be constrained in a manner consistent with their normal use.

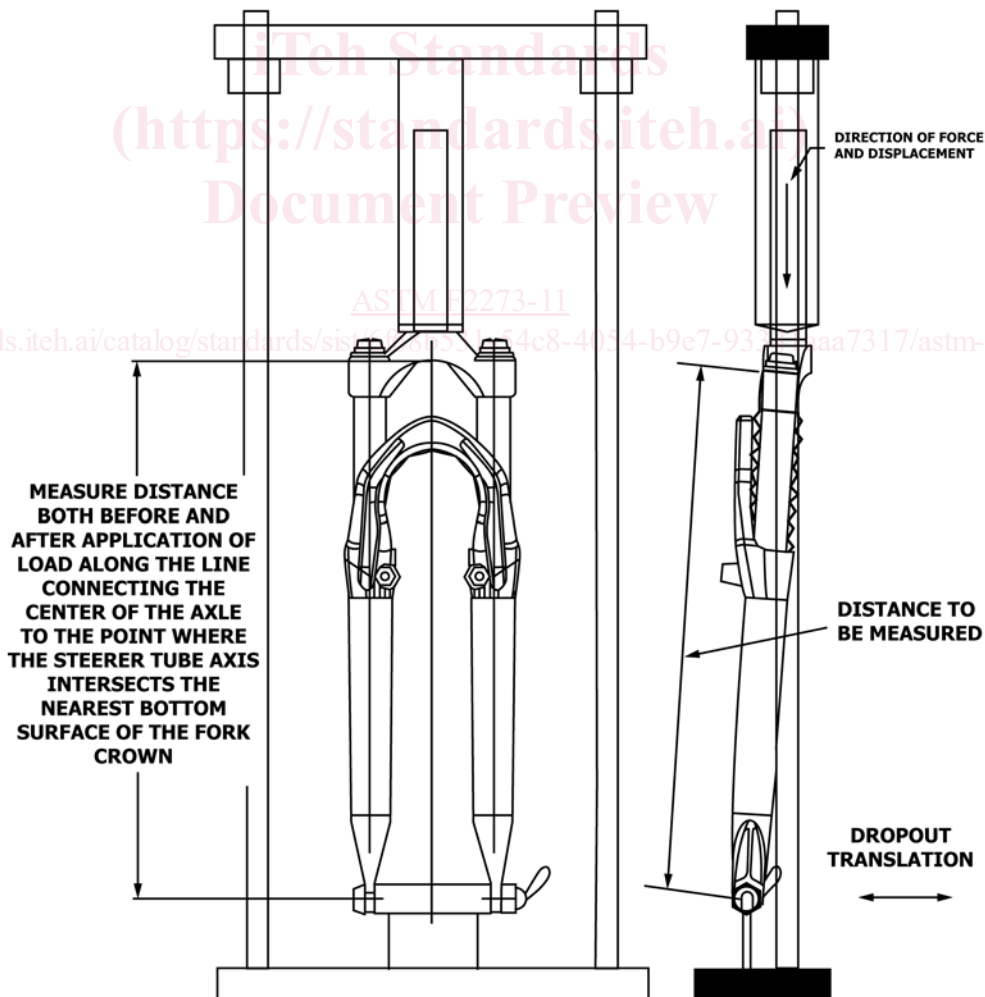

NOTE 1—For some fork designs, a dropout support that allows translation may be required.

FIG. 1 Typical Compression Test Apparatus

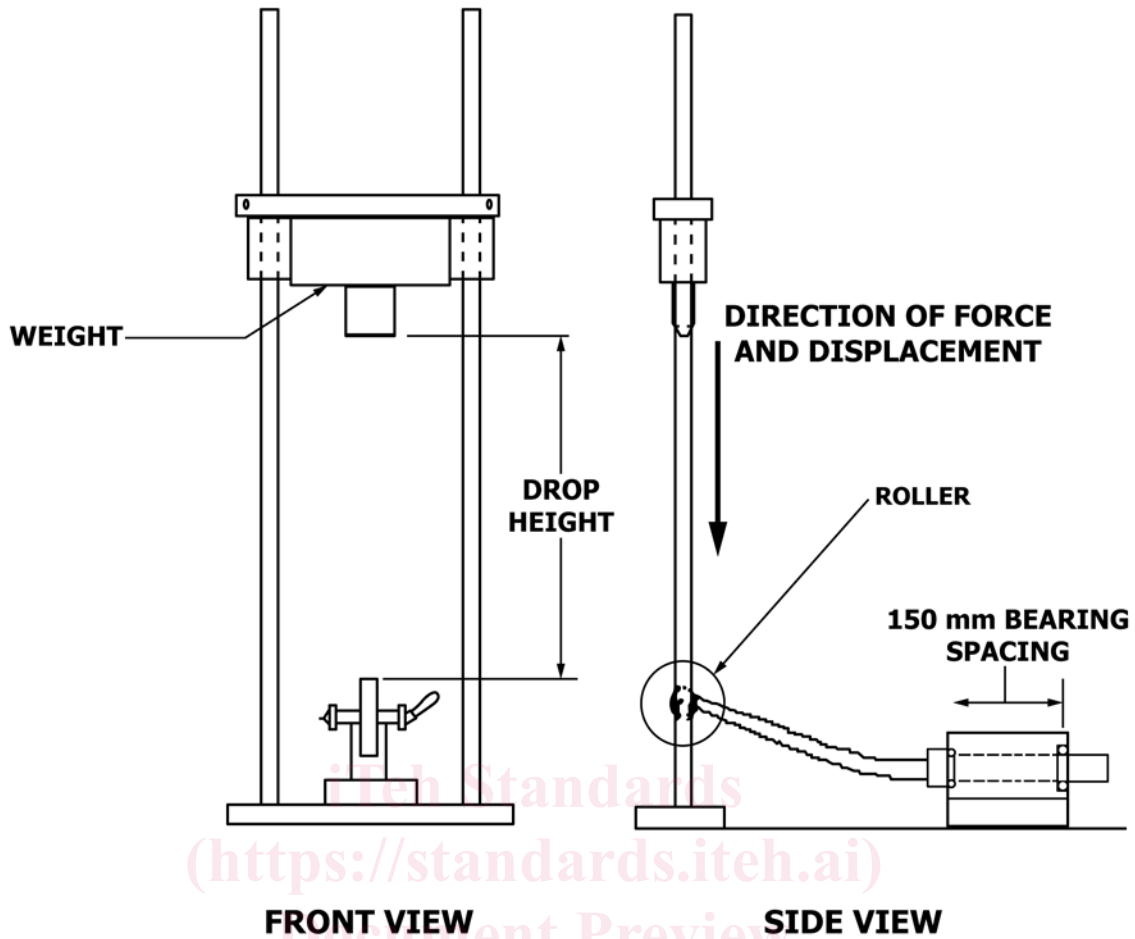

FIG. 2 Bending Load and Impact Test Setup

ASTM F2273-11

6.2.3 The load shall be applied at the dropout centerline in a direction perpendicular to the steerer (Fig. 2).

6.2.4 The dropout centerline shall be free to translate parallel to the steerer tube with either a roller or linkage system.

6.2.5 Deflection at the dropout centerline shall be measured perpendicular to the steerer tube.

6.3 Impact Resistance Test:

6.3.1 A fixture similar to that shown in Fig. 2 is required to position a fork such that the steered tube axis is horizontal and such that the fork is restrained by the steerer tube using standard headset bearings. The fork shall be constrained so that it cannot rotate about the steerer tube axis and the dropout centerline is maintained horizontal.

6.3.2 Bearing separation shall be 150 mm, as shown in Fig. 3. Forks that require bearing installation not consistent with Fig. 3 shall be constrained in a manner consistent with their normal use.

6.3.3 The application of the impact shall be perpendicular to the steerer tube axis at the midpoint of the dropout centerline (Fig. 2).

6.3.4 A roller shall be used (Fig. 2) and shall be of sufficient diameter to ensure that the impactor comes to rest on the roller following impact.

6.3.5 The height of the roller above the support base shall be such that the roller does not contact the base during the test. If the roller does contact the base during the test, the test shall be ruled invalid.

6.3.6 Deflection shall be measured at the dropout centerline in a direction perpendicular to the steerer tube axis.

6.3.7 An apparatus capable of checking whether the connection between the steerer tube and crown can support a prescribed torque applied to the steerer tube about its axis is also required.

6.4 Fatigue Plus Impact Test:

6.4.1 A fixture similar to Fig. 3 is required to support the fork by the steerer tube using bearings as shown.

6.4.2 Bearing separation shall be 150 mm as shown in Fig. 3. Forks that require bearing installation not consistent with Fig. 3 shall be constrained in a manner consistent with their normal use.

6.4.3 The force shall be applied at the dropout in a direction perpendicular to the axis of the steerer tube. An actuator that is capable of providing a fully reversed force of constant amplitude shall be used.

6.4.4 The dropout centerline shall be free to translate perpendicular to the direction of load application.