



Designation: ~~B955/B955M-10~~ Designation: B955/B955M - 11

Standard Specification for Aluminum-Alloy Centrifugal Castings¹

This standard is issued under the fixed designation B955/B955M; the number immediately following the designation indicates the year of original adoption or, in the case of revision, the year of last revision. A number in parentheses indicates the year of last reapproval. A superscript epsilon (ϵ) indicates an editorial change since the last revision or reapproval.

1. Scope*

- 1.1 This specification covers aluminum-alloy centrifugal castings designated as shown in Table 1.
- 1.2 This specification is not intended for aluminum-alloy centrifugal castings used in aerospace applications.
- 1.3 Alloy and temper designations are in accordance with ANSI H35.1 / H35.1 (M). The equivalent unified numbering system alloy designations are in accordance with Practice E527.
- 1.4 Unless the order specifies the “M” specification designation, the material shall be furnished to the inch-pound units.
- 1.5 For acceptance criteria for inclusion of new aluminum and aluminum alloys and their properties in this specification, see Annex A1 and Annex A2.
- 1.6 *Units*—The values stated in either SI units or inch-pound units are to be regarded separately as standard. The values stated in each system may not be exact equivalents; therefore, each system shall be used independently of the other. Combining values from the two systems may result in non-conformance with the standard.
- 1.7 *This standard does not purport to address all of the safety concerns, if any, associated with its use. It is the responsibility of the user of this standard to establish appropriate safety and health practices and determine the applicability of regulatory limitation prior to use.*

2. Referenced Documents

2.1 The following documents of the issue in effect on the date of casting purchase form a part of this specification to the extent referenced herein:

2.2 *ASTM Standards*:²

- B179 [Specification for Aluminum Alloys in Ingot and Molten Forms for Castings from All Casting Processes](#)
- B275 [Practice for Codification of Certain Nonferrous Metals and Alloys, Cast and Wrought](#)
- B557 [Test Methods for Tension Testing Wrought and Cast Aluminum- and Magnesium-Alloy Products](#)
- B557M [Test Methods for Tension Testing Wrought and Cast Aluminum- and Magnesium-Alloy Products \(Metric\)](#)
- B660 [Practices for Packaging/Packing of Aluminum and Magnesium Products](#)
- B881 [Terminology Relating to Aluminum- and Magnesium-Alloy Products](#)
- B917/B917M [Practice for Heat Treatment of Aluminum-Alloy Castings from All Processes](#)
- D3951 [Practice for Commercial Packaging](#)
- E29 [Practice for Using Significant Digits in Test Data to Determine Conformance with Specifications](#)
- E34 [Test Methods for Chemical Analysis of Aluminum and Aluminum-Base Alloys](#)
- E94 [Guide for Radiographic Examination](#)
- E155 [Reference Radiographs for Inspection of Aluminum and Magnesium Castings](#)
- E165 [Practice for Liquid Penetrant Examination for General Industry](#)
- E527 [Practice for Numbering Metals and Alloys in the Unified Numbering System \(UNS\)](#)
- E607 [Test Method for Atomic Emission Spectrometric Analysis Aluminum Alloys by the Point to Plane Technique Nitrogen Atmosphere](#)
- E716 [Practices for Sampling and Sample Preparation of Aluminum and Aluminum Alloys for Determination of Chemical Composition by Spectrochemical Analysis](#)
- E1251 [Test Method for Analysis of Aluminum and Aluminum Alloys by Atomic Emission Spectrometry—Test Method for Analysis of Aluminum and Aluminum Alloys by Atomic Emission Spectrometry](#)
- E2422 [Digital Reference Images for Inspection of Aluminum Castings](#)

¹ This specification is under the jurisdiction of ASTM Committee B07 on Light Metals and Alloys and is the direct responsibility of Subcommittee B07.01 on Aluminum Alloy Ingots and Castings.

Current edition approved Nov. May 1, 2010; 2011. Published December 2010; June 2011. Originally approved in 2007. Last previous edition approved in 2008; 2010 as B955/B955M-10.8. DOI: 10.1520/B0955_B0955M-10.1.

² For referenced ASTM standards, visit the ASTM website, www.astm.org, or contact ASTM Customer Service at service@astm.org. For *Annual Book of ASTM Standards* volume information, refer to the standard's Document Summary page on the ASTM website.

*A Summary of Changes section appears at the end of this standard.

TABLE 1 Chemical Composition Limits^{A,B,C}

Alloy		Composition, %														
ANSI ^D	UNS	Silicon	Iron	Copper	Manga- nese	Magnesium	Chromium	Nickel	Zinc	Titanium	Tin	Other Elements ^E		Aluminum		
														Each	Total ^F	
356.0	A03560	6.5–7.5	0.6 ^G	0.25	0.35 ^G	0.20–0.45	0.35	0.25	0.05	0.15	Remainder	
505.0		0.40–0.8	0.7	0.15–0.40	0.15	0.8–1.2	0.04–0.35	...	0.25	0.15	0.05	0.15	Remainder	
709.0		0.40	0.50	1.2–2.0	0.30	2.1–2.9	0.18–0.28	...	5.1–6.1	0.20	0.05	0.15	Remainder	
850.0	A08500	0.7	0.7	0.7–1.3	0.10	0.10	...	0.7–1.3	...	0.20	5.5–7.0	0.30	Remainder	

^A When single units are shown, these indicate the maximum amounts permitted.

^B Analysis shall be made for the elements for which limits are shown in this table.

^C The following applies to all specified limits in this table: For purposes of determining conformance to these limits, an observed value or a calculated value obtained from analysis shall be rounded to the nearest unit in the last right-hand place of figures used in expressing the specified limit in accordance with the rounding method of Practice E29.

^D ASTM alloy designations are defined in ANSI H35.1/H35.1 (M)

^E *Others* includes listed elements for which no specific limit is shown as well as unlisted metallic elements. The producer may analyze samples for trace elements not specified in the specification. However, such analysis is not required and may not cover all metallic *Others* elements. Should any analysis by the producer or the purchaser establish that an *Others* element exceeds the limit of *Each* or that the aggregate of several *Others* elements exceeds the limit of *Total*, the material shall be considered nonconforming.

^F *Other Elements*—Total shall be the sum of unspecified metallic elements 0.010 % or more, rounded to the second decimal before determining the sum.

^G If the iron content exceeds 0.45 %, manganese content shall not be less than one half of the iron.

2.3 ANSI Standard:³

H35.1 / H35.1 (M) American National Standard Alloy and Temper Designation Systems for Aluminum

Z1.4 Sampling Procedures and Tables for Inspection by Attributes

2.4 Military Standards:⁴

MIL-STD-129 Marking for Shipment and Storage

MIL-STD-276 Impregnation of Porous Nonferrous Metal Castings

2.5 Naval Standard:⁵

S9074-AR-GIB-010/278 Requirements for Fabrication Welding and Inspection, and Casting Inspection and repair for Machinery, Piping, and Pressure Vessels

2.6 Federal Standard:⁴

Fed Std. No. 123 Marking for Shipment (Civil Agencies)

2.7 Other Standards:⁶

CEN EN 14242 Aluminum and aluminum alloys. Chemical analysis. Inductively coupled plasma optical emission spectral analysis.

ASTM B955/B955M-11

3. Terminology <https://standards.iteh.ai/catalog/standards/sist/ce5bfa86-ba62-4425-9ed2-4997f2153d35/astm-b955-b955m-11>

3.1 *Definitions*—Refer to Terminology B881 for definitions of product terms used in this specification.

3.1.1 *Hot Isostatic Processing (HIP, HIPped, and HIPping)*—the process of applying high pressure and temperatures to a part through the medium of a pressurized gas, such as Argon or Nitrogen to remove internal porosity voids.

4. Ordering Information

4.1 Orders for material under this specification shall include the following information:

4.1.1 This specification designation (which includes the number, the year, and the revision letter, if applicable),

NOTE 1—For inch-pound application, specify Specification B955 and for metric application specify Specification B955M. Do not mix units.

4.1.2 Alloy (see Section 7 and Table 1),

4.1.3 Temper (see Section 9 and Table 2 [Table 3]),

4.1.4 Applicable drawing or part number,

4.1.5 The quantity in either pieces or pounds.

4.2 Additionally, orders for material to this specification shall include the following information when required by the purchaser:

4.2.1 Whether chemical composition samples are to be taken from the castings (see 7.2),

4.2.2 Whether foundry control is required (see section 8.2),

4.2.3 Whether yield strength tests are required (see Section 9 and Table 2, Footnote D, [Table 3], Footnote D),

³ Available from Aluminum Association, Inc., 1525 Wilson Blvd., Suite 600, Arlington, VA 22209, <http://www.aluminum.org>.

⁴ Available from Standardization Documents Order Desk, DODSSP, Bldg. 4, Section D, 700 Robbins Ave., Philadelphia, PA 19111-5098, <http://www.dodssp.daps.mil>.

⁵ Available from Naval Sea Systems Command (NAVSEA), 1333 Isaac Hull Ave., SE, Washington, DC 20376, <http://www.navsea.navy.mil>.

⁶ Available from European Committee for Standardization (CEN), 36 rue de Stassart, B-1050, Brussels, Belgium, <http://www.CEN.eu/research>.

TABLE 2 Tensile Requirements, (Inch-Pound Units)^{A, B}

Alloy		Temper ^C	Tensile Strength, min, ksi	Yield Strength ^D (0.2 % offset), min, ksi	Elongation in 2 in. or 4 × Diameter, min, %	Typical Brinell Hardness ^E 500-kgf load, 10-mm ball
ANSI ^F	UNS					
356.0	A03560	T6 separately cast specimens	33.0	22.0	3.0	85
505.0		T61 specimens cut from castings ^G	43.0	37.0	7.0	95
709.0		T61 specimens cut from castings ^H	74.0	64.0	4.0	150
850.0	A08500	T5 separately cast specimens	18.0	...	8.0	...

^A If agreed upon by manufacturer and the purchaser, other mechanical properties may be obtained by other heat treatments such as annealing, aging, or stress relieving.

^B For purposes of determining conformance with this specification, each value for tensile strength and yield strength shall be rounded off to the nearest 0.1 ksi, and each value for elongation shall be rounded to the nearest 0.5 %, both in accordance with the rounding method of Practice E29.

^C Temper designations are defined in ANSI H35.1/H35.1 (M) T61 Hot Isostatic Pressed (HIP), solution heat-treated, and then artificially aged.

^D Yield strength to be evaluated only when specified in contract or purchase order.

^E Hardness values given for information only, not required for acceptance.

^F ASTM alloy designations are recorded in Practice B275.

^G These properties apply only to castings having section thicknesses not greater than 2.5 in. Tensile specimens were taken from the casting after HIPping was completed. The data used to calculate the minimum values came from samples taken in the axial direction. While not combinable with the axial data, tangential values are marginally higher.

^H These properties apply only to castings having section thicknesses not greater than 2.5 in. Tensile specimens were taken from the casting after HIPping was completed. Samples were taken in both the axial and tangential directions and the data was found to be combinable. The data represents both directions.

TABLE 3 Tensile Requirements, (SI Units) – (Metric)^{A, B, C}

Alloy		Temper ^D	Tensile Strength, min, MPa	Yield Strength ^E (0.2 % offset), min, MPa	Elongation in 5D min, %	Typical Brinell Hardness ^F 500-kgf load, 10-mm ball
ANSI ^G	UNS					
356.0	A03560	T6 separately cast specimens	230	150	3.0	85
505.0		T61 specimens cut from castings ^H	295	255	6.0	95
709.0		T61 specimens cut from castings ^I	510	440	4.0	150
850.0	A08500	T5 separately cast specimens	125	...	7.0	...

^A If agreed upon by manufacturer and the purchaser, other mechanical properties may be obtained by other heat treatments such as annealing, aging, or stress relieving.

^B For purposes of determining conformance with this specification, each value for tensile strength and yield strength shall be rounded off to the nearest 1 MPa, and each value for elongation shall be rounded to the nearest 0.5 %, both in accordance with the rounding method of Practice E29.

^C Guidelines for metric conversion from the "Tempers for Aluminum and Aluminum Alloys, Metric Edition" (Tan Sheets) Appendix A, were used to convert the tensile and yield values to SI units.³

^D Temper designations are defined in ANSI H35.1/H35.1 (M) T61 Hot Isostatic Pressed (HIP), solution heat-treated, and then artificially aged.

^E Yield strength to be evaluated only when specified in contract or purchase order.

^F Hardness values given for information only, not required for acceptance.

^G ASTM alloy designations are recorded in Practice B275.

^H These properties apply only to castings having section thicknesses not greater than 2.5 in. Tensile specimens were taken from the casting after HIPping was completed. The data used to calculate the minimum values came from samples taken in the axial direction. While not combinable with the axial data, tangential values are marginally higher.

^I These properties apply only to castings having section thicknesses not greater than 2.5 in. Tensile specimens were taken from the casting after HIPping was completed. Samples were taken in both the axial and tangential directions and the data was found to be combinable. The data represents both directions.

4.2.4 Whether test specimens are to be cut from castings in addition to or instead of centrifugally cast test blocks (see Sections 9, 10.1, 11.2, and 13),

4.2.5 Whether special tensile test sampling agreement is required for large castings (Section 10.3.2),

4.2.6 Whether repairs are permissible (see Section 16),

4.2.7 Whether inspection is required at the producer's works (see Section 17),

4.2.8 Whether surface requirements will be checked visually or by observational standards where such standards are established (see 18.1),

4.2.9 Whether liquid penetrant inspection is required (see 18.2),

4.2.10 Whether radiographic inspection is required (see

4.2.10 Whether radiographic inspection is required and if so the radiographic grade of casting required (18.3 and Table 4),

4.2.11 Whether certification is required (see Section 21), and

4.2.12 Whether Practices B660 applies and, if so, the levels of preservation, packaging and packing required (see 22.4).

4.2.13 Whether marking in accordance with Fed. Std. 123 or D3951 or MIL-STD-129 applies (22.4).

5. Responsibility for Quality Assurance

5.1 Unless otherwise specified in the contract or purchase order, the producer shall be responsible for the performance of all inspections and test requirements specified herein. Unless otherwise agreed upon, the producer may use his own or any other

TABLE 4 Discontinuity—Level Requirements for Aluminum Castings in Accordance with Film Reference Radiographs E155 or Digital Reference Radiographs E2422

Discontinuity	Radiograph	Grade A ^A		Grade B		Grade C		Grade D	
		1/4 to 3/4		Section Thickness, in.		Section Thickness, in.		Section Thickness, in.	
		[6 to 19 mm]	1/4 [6 mm]	3/4 [19 mm]	1/4 [6 mm]	3/4 [19 mm]	1/4 [6 mm]	3/4 [19 mm]	
Gas holes	1.1	none	1	1	2	2	5	5	
Gas porosity (round)	1.21	none	1	1	3	3	7	7	
Gas porosity (elongated)	1.22	none	1	1	3	4	5	5	
Shrinkage cavity	2.1	none	1	^B	2	^B	3	^B	
Shrinkage porosity or sponge	2.2	none	1	1	2	2	4	3	
Foreign material (less dense material)	3.11	none	1	1	2	2	4	4	
Foreign material (more dense material)	3.12	none	1	1	2	1	4	3	
Segregation	none	none	none	none	none	none	none	
Cracks	none	none	none	none	none	none	none	
Cold shuts	none	none	none	none	none	none	none	
Laps	none	none	none	none	none	none	none	
Surface irregularity	not to exceed drawing tolerance on any grade casting							
Core shift	not to exceed drawing tolerance on any grade casting							

^A Caution should be exercised in requesting grade A because of the difficulty in obtaining this level.

^B Not available. Use 1/4 in. for all thicknesses.

suitable facilities for the performance of the inspection and test requirements specified herein. The purchaser shall have the right to perform any of the inspections and tests set forth in the specification where such inspections are deemed necessary to confirm that the material conforms to prescribed requirements.

6. Materials and Manufacture

6.1 The responsibility of furnishing castings that can be laid out and machined to the finished dimensions within the permissible variations specified, as shown on the blueprints or drawings, shall rest with the producer, except where mold equipment is furnished by the purchaser.

7. Chemical Composition

7.1 The Product shall conform to the chemical composition limits prescribed in Table 1. Conformance shall be determined by the producer by taking samples at the time castings are poured in accordance with E716 and analyzed in accordance with E716, E607, E1251, E34 or EN 14242. If the producer has determined the composition of the material during casting, they shall not be required to sample and analyze the finished product.

7.2 If it becomes necessary to analyze castings for conformance to chemical composition limits, the method used to sample castings for the determination of chemical composition shall be by agreement between the producer and the purchaser. Analysis shall be performed in accordance with E716, E607, E1251, E34 or EN 14242 (ICP method)

7.3 Other methods of analysis or in the case of a dispute the method of analysis shall be agreed upon by the producer and the purchaser.

7.4 A sample for determination of chemical composition shall be taken to represent one of the following:

7.4.1 Not more than 4000 lb [2000 kg] of clean castings or a single casting poured from one furnace. The maximum elapsed time between determinations shall be established for each alloy but in any case this maximum elapsed time shall not exceed 8 hours.

8. Requirements for Castings Produced for Governmental and Military Agencies

8.1 Material Requirements:

8.1.1 Unless otherwise specified, only aluminum alloy conforming to the requirements of Specification B179 or producers foundry scrap, identified as being made from alloy conforming to Specification B179, shall be used in the remelting furnace from which molten metal is taken for pouring directly into castings. Additions of small amounts of modifying and grain refining elements or alloys are permitted.

8.1.2 Pure materials, recycled materials, and master alloys may be used to make alloys conforming to this specification, provided chemical analysis can be taken and adjusted to conform to Table 1 prior to pouring any castings.

8.2 *Foundry Control*—When specified, castings shall be produced under procedures established and documented for foundry control that have been approved by the purchaser. Foundry control shall consist of examination of castings by radiographic or other approved methods for determining internal discontinuities until the gating, pouring, and other foundry practices have been established to produce castings meeting the quality standards furnished by the purchaser or agreed upon by the purchaser and the producer. When foundry practices have been so established, the production method shall be documented and shall not be

significantly changed without demonstrating to the satisfaction of the purchaser that the change does not adversely affect the quality of the castings. Minor changes of $\pm 50^{\circ}\text{F}$ [$\pm 28^{\circ}\text{C}$] from the established nominal pouring temperature are permissible.

9. Tensile Requirements

9.1 When specified, the tensile strength, yield strength, and elongation of test specimens cut from castings shall meet the values stated in Table 2 [Table 3].

9.2 The tensile strength, yield strength, and elongation of test specimens cut from castings or test blocks for alloys 505.0 and 709.0, which have been hippped and then heat treated shall be in accordance with Table 2 [Table 3]. For other alloys specimens cut from castings shall meet a minimum of 75 % of the tensile and yield strength values and not less than 25 % of the elongation values specified in Table 2 [Table 3]. The measurement of elongation is not required for test specimens cut from castings if 25 % of the specified minimum elongation value published in Table 2 [Table 3] is 0.5 % or less. If grade D quality castings as described in Table 4 are specified, no tensile tests shall be specified nor tensile requirements be met on specimens cut from castings.

10. Test Specimens

10.1 Test specimens shall be cut from production castings or by agreement between purchaser and producer cut from centrifugally cast test blocks as shown in Figs. 1 and 2.

10.1.1 The centrifugally cast test blocks shall be cast in molds representing the mold used for castings and cast from the same melt which is used for the castings after the last melt addition.

10.1.2 The centrifugally cast test blocks shall be heat treated with the castings they represent.

10.2 *Tensile Specimens*—Test specimens shall be as shown in Fig. 9 or 10 of Test Methods B557 [B557M] using the largest specimen obtainable from the casting or test block. In no case shall the smallest specimen be less than the 0.250 [6mm] specimen shown in Fig. 9 of Test Methods B557 [B557M].

10.3 *Tensile Properties*—The tensile properties shall be determined in accordance with Test Methods B557 or B557M. When the size or shape of the casting restricts the use of test specimens, or when otherwise determined, the full-size casting may be tested. When a complete casting test is required, the strength requirement and the direction or method of loading of the full-size casting shall be specified on the drawing for the part concerned.

10.3.1 *Tensile Properties—Small Castings*—Castings shall be selected at random from each lot, after heat treatment and nondestructive testing operations have been completed, in accordance with an appropriate sampling plan (recommended ANSI Z1.4, Inspection Level S-2, acceptance number zero). Tension test coupons shall be cut from locations specified on the engineering drawing. If no location is shown, three specimens shall be taken from a thick, medium, and thin section of each casting selected at random. Tests of these coupons must meet the tensile property requirements specified for the zone of the casting from which they were taken. In the event of a failure of any test the lot of castings that the sample represents shall be rejected pending material review board action by the purchaser.

10.3.2 *Tensile Properties—Larger Castings*—By agreement between the purchaser and the producer, the frequency of tensile test sampling and the locations the tension test coupons are to cut from the casting shall be determined and specified on the engineering drawing.

10.4 Test specimens shall be machined from the test blocks or production castings after all hippping, heat treatment and nondestructive testing operations have been completed.

10.5 When necessary, a rectangular specimen that is proportional to that shown for 0.500 in. [12.5 mm] wide specimen in Fig. 6 of test method B557 [B557M] may be used.

11. Number of Tests

11.1 Unless otherwise agreed upon by the purchaser and producer, a single test specimen shall be tested to represent the following:

11.1.1 Not more than 4000 lb [2000 kg] of clean castings (gates and risers removed) or a single casting poured from one furnace.

11.1.2 The castings poured continuously from one furnace in not more than eight consecutive hours.

11.2 When tensile properties of castings are to be determined, one per melt-heat combination shall be tested unless otherwise shown on the drawing or specified in the purchase order.

12. Test Methods

12.1 The tensile properties shall be determined in accordance with Test Methods B557 [B557M].

13. Retests

13.1 If the results of the tension test do not conform to the requirements prescribed in Table 2 [Table 3], test bars representative of the castings may be retested in accordance with the replacement tests and retest provisions of Test Methods B557 [B557M] and the results of retests shall conform to the requirements as to mechanical properties specified in Table 2 [Table 3].

14. Workmanship, Finish, and Appearance

14.1 The finished castings shall be uniform in composition and free of blowholes, cracks, shrinks, and other discontinuities in accordance with standards designated and agreed upon as acceptable by the purchaser.

Axial Specimen

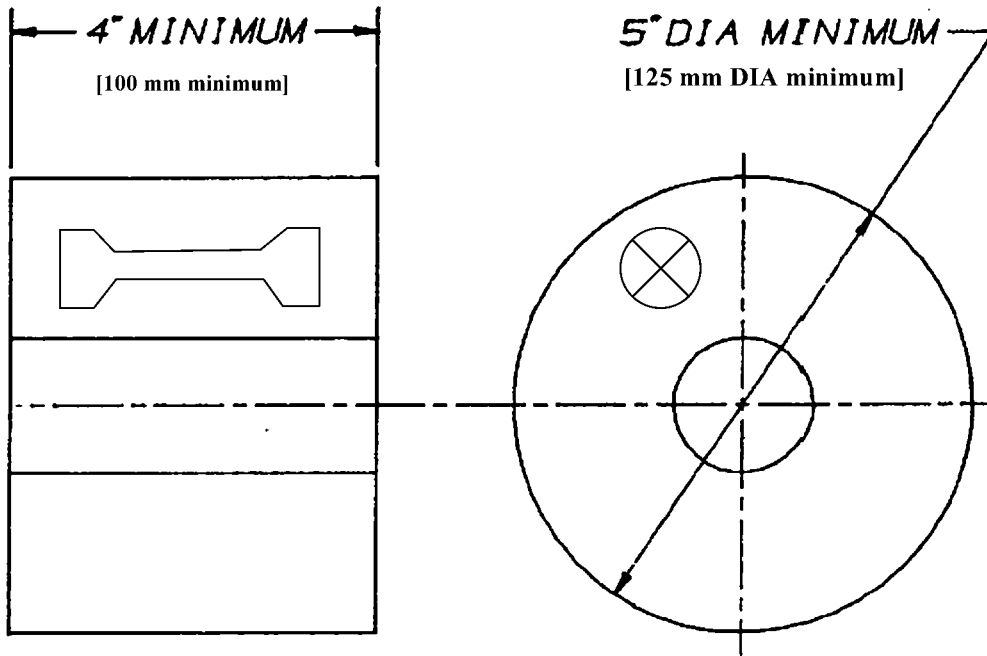

Tangential Specimen

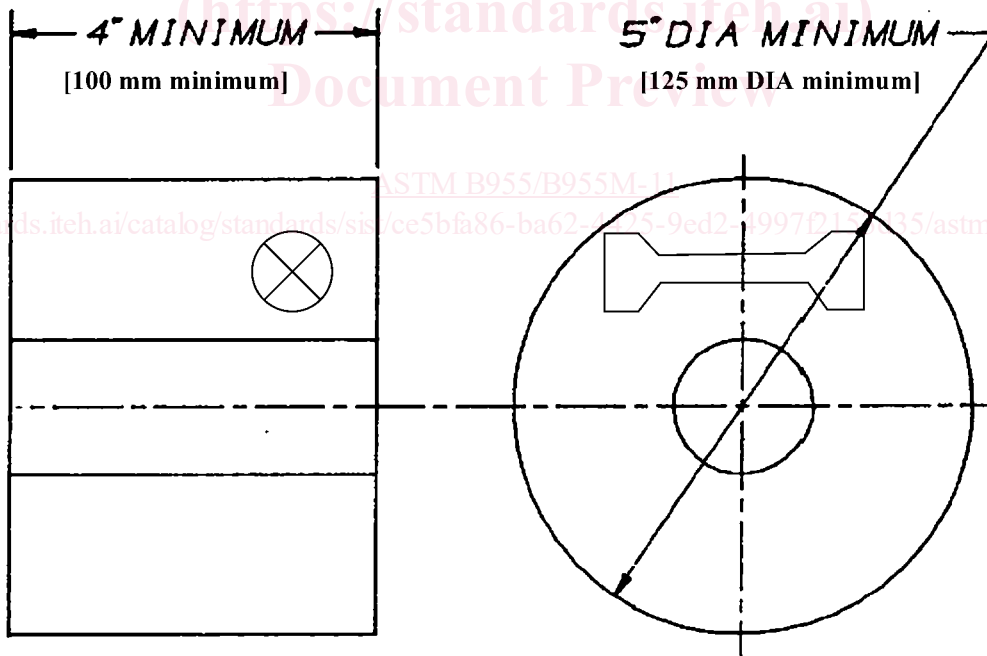

FIG. 1 Configuration of Cast Centrifugal Test Block with Potential Locations of Machined Test Specimen.

15. Heat Treatment

15.1 Heat treatment of castings shall be performed in accordance with Practice B917/B917M.

16. Repair of Castings

16.1 Castings may be repaired only by processes approved and agreed upon by the producer and purchaser, such as, welding, impregnation, peening, blending, soldering, and so forth. Limitations on the extent and frequency of such repairs, and methods of inspection of repaired areas should also be agreed upon.