



Designation: E 976 – 00

Standard Guide for Determining the Reproducibility of Acoustic Emission Sensor Response¹

This standard is issued under the fixed designation E 976; the number immediately following the designation indicates the year of original adoption or, in the case of revision, the year of last revision. A number in parentheses indicates the year of last reapproval. A superscript epsilon (ϵ) indicates an editorial change since the last revision or reapproval.

1. Scope

1.1 This guide defines simple economical procedures for testing or comparing the performance of acoustic emission sensors. These procedures allow the user to check for degradation of a sensor or to select sets of sensors with nearly identical performances. The procedures are not capable of providing an absolute calibration of the sensor nor do they assure transferability of data sets between organizations.

1.2 *This standard does not purport to address all of the safety concerns, if any, associated with its use. It is the responsibility of the user of this standard to establish appropriate safety and health practices and determine the applicability of regulatory limitations prior to use.*

2. Significance and Use

2.1 Acoustic emission data is affected by several characteristics of the instrumentation. The most obvious of these is the system sensitivity. Of all the parameters and components contributing to the sensitivity, the acoustic emission sensor is the one most subject to variation. This variation can be a result of damage or aging, or there can be variations between nominally identical sensors. To detect such variations, it is desirable to have a method for measuring the response of a sensor to an acoustic wave. Specific purposes for checking sensors include: (1) checking the stability of its response with time; (2) checking the sensor for possible damage after accident or abuse; (3) comparing a number of sensors for use in a multichannel system to ensure that their responses are adequately matched; and (4) checking the response after thermal cycling or exposure to a hostile environment. It is very important that the sensor characteristics be always measured with the same sensor cable length and impedance as well as the same preamplifier or equivalent. This guide presents several procedures for measuring sensor response. Some of these procedures require a minimum of special equipment.

¹ This guide is under the jurisdiction of ASTM Committee E07 on Nondestructive Testing and is the direct responsibility of Subcommittee E07.04 on Acoustic Emission.

Current edition approved Dec. 10, 2000. Published February 2001. Originally published as E 976 – 84. Last previous edition E 976 – 99.

3. Principles of Application

3.1 The procedures given in this guide are designed to measure the response of an acoustic emission sensor to an arbitrary but repeatable acoustic wave. These procedures in *no* way constitute a calibration of the sensor. The absolute calibration of a sensor requires a complete knowledge of the characteristics of the acoustic wave exciting the sensor or a previously calibrated reference sensor. In either case, such a calibration is beyond the scope of this guide.

3.2 The fundamental requirement for comparing sensor responses is a source of repeatable acoustic waves. The characteristics of the wave do not need to be known as long as the wave can be reproduced at will. The sources and geometries given in this guide will produce primarily compressional waves. While the sensors will respond differently to different types of waves, changes in the response to one type of wave will imply changes in the responses to other types of waves.

3.3 These procedures all use a test block or rod. Such a device provides a convenient mounting surface for the sensor and when appropriately marked, can ensure that the source and the sensor are always positioned identically with respect to each other. The device or rod also provides mechanical loading of the sensor similar to that experienced in actual use. Care must be taken when using these devices to minimize resonances so that the characteristics of the sensor are not masked by these resonances.

3.4 These procedures allow comparison of responses only on the same test setup. No attempt should be made to compare responses on different test setups, whether in the same or separate laboratories.

4. Apparatus

4.1 The essential elements of the apparatus for these procedures are: (1) the acoustic emission sensor under test; (2) a block or rod; (3) a signal source; and (4) measuring and recording equipment.

4.1.1 Block diagrams of some of the possible experimental setups are shown in Fig. 1.

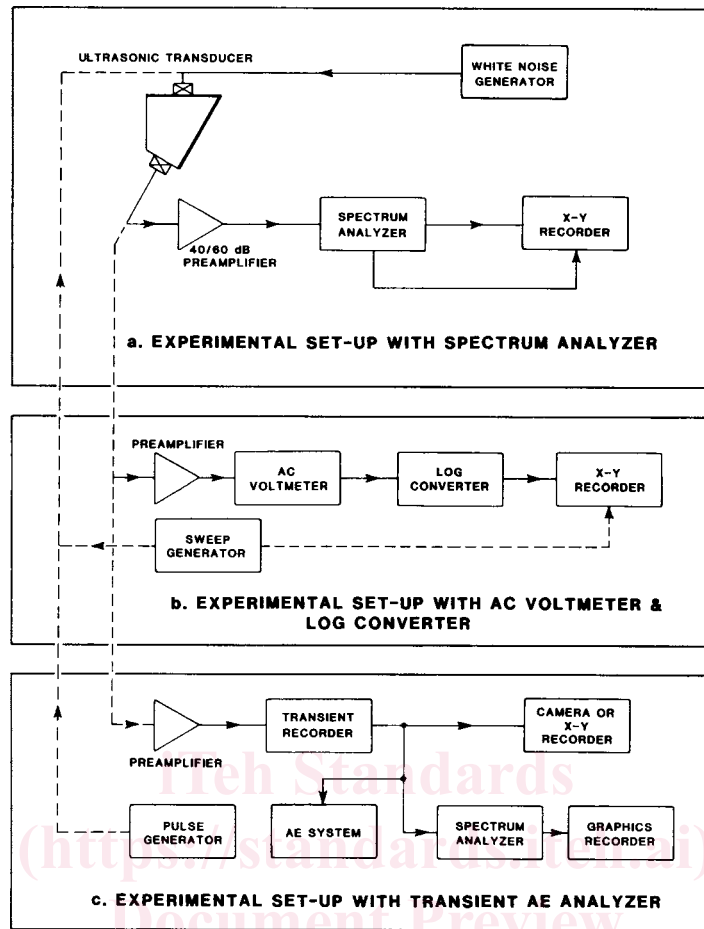

FIG. 1 Block Diagrams of Possible Experimental Setups

4.2 *Blocks*—The design of the block is not critical. However, the use of a “nonresonant” block is recommended for use with an ultrasonic transducer and is required when the transducer drive uses any form of coherent electrical signal.

4.2.1 *Conical “Nonresonant” Block*—The Beattie block, shown in Fig. 2, can be machined from a 10-cm (4-in.) diameter metal billet. The preferred materials are aluminum and low-alloy steel. After the bottom is faced and the taper cut, the block is clamped at a 10° angle and the top face is milled. The dimensions given will provide an approximate circle just over 2.5 cm (1 in.) in diameter for mounting the sensor. The acoustic excitation should be applied at the center of the bottom face. The conic geometry and lack of any parallel surfaces reduce the number of mechanical resonances that the block can support. A further reduction in possible resonances of the block can be achieved by roughly machining all surfaces except where the sensor and exciter are mounted and coating them with a layer of metal-filled epoxy.

4.2.2 *Gas-Jet Test Block*—Two gas-jet test blocks are shown in Fig. 3. The block shown in Fig. 3(a) is used for opposite surface comparisons, which produce primarily compressional waves. That shown in Fig. 3(b) is for same surface comparisons which produce primarily surface waves. The “nonresonant” block described in 4.2.1 can also be used with a gas jet in order to avoid exciting many resonant modes. The blocks in Fig. 3 have been used successfully but their design is

not critical. However it is suggested that the relative positions of the sensor and the jet be retained.

4.2.3 *Acrylic Polymer Rod*—A polymethylmethacrylate rod is shown in Fig. 4. The sensor is mounted on the end of the rod and the acoustic excitation is applied by means of pencil lead break, a consistent distance from the sensor end of the rod. See Appendix X1 for additional details on this technique.

4.3 *Signal Sources*—Three signal sources are recommended: an electrically driven ultrasonic transducer, a gas jet, and an impulsive source produced by breaking a pencil lead.

4.3.1 *Ultrasonic Transducer*—Repeatable acoustic waves can be produced by an ultrasonic transducer permanently bonded to a test block. The transducer should be heavily damped to provide a broad frequency response and have a center frequency in the 2.25 to 5.0-MHz range. The diameter of the active element should be at least 1.25 cm (0.5 in.) to provide measurable signal strength at the position of the sensor under test. The ultrasonic transducer should be checked for adequate response in the 50 to 200-kHz region before permanent bonding to the test block.

4.3.1.1 *White Noise Generator*—An ultrasonic transducer driven by a white noise generator produces an acoustic wave that lacks coherent wave trains of many wave lengths at one frequency. This lack of coherent wave trains greatly reduces the number and strength of the mechanical resonances excited in a structure. Therefore, an ultrasonic transducer driven by a

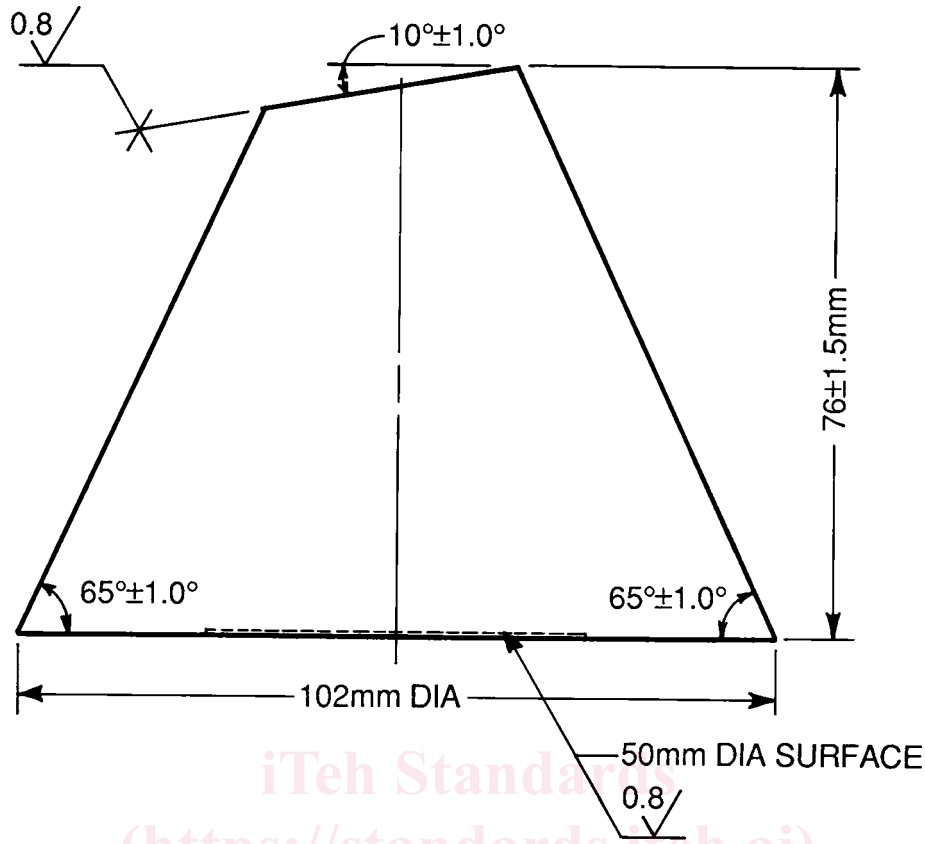

FINISH: $\sqrt{3.2}$ & NOTED
 BREAK EDGES 0.1mm MAX.

FIG. 2 The Beattie Block

<https://standards.iteh.ai/catalog/standards/sist/321b9063-1661-4a94-9b18-8fce7517826d/astm-e976-00>

white-noise generator can be used with a resonant block having parallel sides. However, the use of a “nonresonant” block such as that described in 4.2.1 is strongly recommended. The generator should have a white-noise spectrum covering at least the frequency range from 10 kHz to 2 MHz and be capable of an output level of 1 V rms.

4.3.1.2 *Sweep Generator*—The ultrasonic transducer can be driven by a sweep generator in conjunction with a “nonresonant” block. Even with this block, some resonances will be produced that may partially mask the response of the sensor under test. The sweep generator should have a maximum frequency of at least 2 MHz and the sweep speed should be compatible with the XY recorder used. It is recommended that a sweep generator be used with an a-c voltmeter with a logarithmic output.

4.3.1.3 *Pulse Generator*—The ultrasonic transducer may be excited by a pulse generator. The pulse width should be either slightly less than one-half the period of the center frequency of the transducer ($\leq 0.22 \mu\text{s}$ for a 2.25 MHz transducer) or longer than the damping time of the sensor, block, and transducer (typically $>10 \text{ ms}$). The pulse repetition rate should be low

(<100 pulses/s) so that each acoustic wave train is damped out before the next one is excited.

4.3.1.4 The pulse generator should be used with an oscilloscope and camera or, in single-pulse mode, with the counter in an acoustic emission system. Not enough energy is generated above 200 kHz for effective use with a spectrum analyzer.

4.3.2 *Gas Jet*—Suitable gases for this apparatus are extra dry air, helium, etc. A pressure between 150 and 200 kPa (20 to 30 psi) is recommended for helium or extra dry air. Once a pressure and a gas has been chosen, all further tests with the apparatus should use that gas and pressure. The gas jet should be permanently attached to the test block (see Fig. 3(a) and 3(b)).

4.3.3 *Pencil Lead Break*—A repeatable acoustic wave can be generated by carefully breaking a pencil lead against the test block or rod. When the lead breaks, there is a sudden release of the stress on the surface of the block where the lead is touching. This stress release generates an acoustic wave. The Hsu pencil source uses a mechanical pencil with a 0.3-mm diameter lead (0.5-mm lead is also acceptable but produces a larger signal). The Nielsen shoe, shown in Fig. 5 can aid in

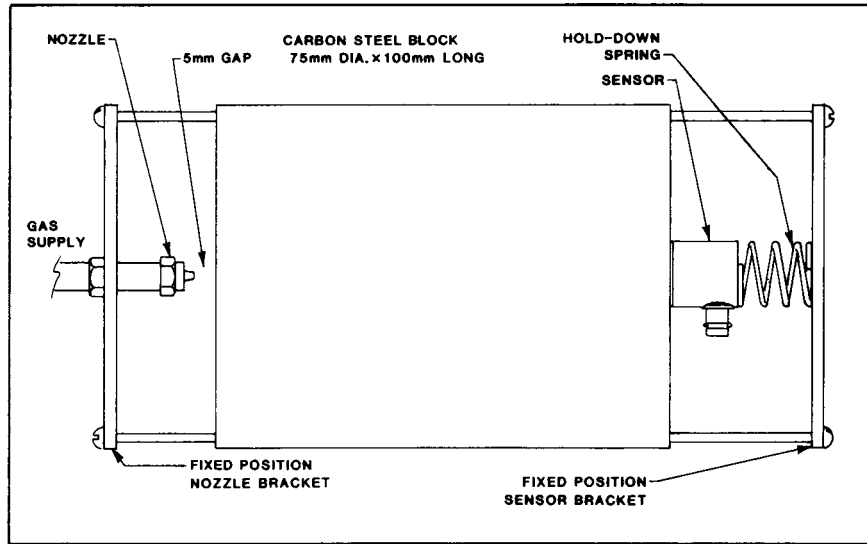

(a) Opposite Surface Comparison Setup

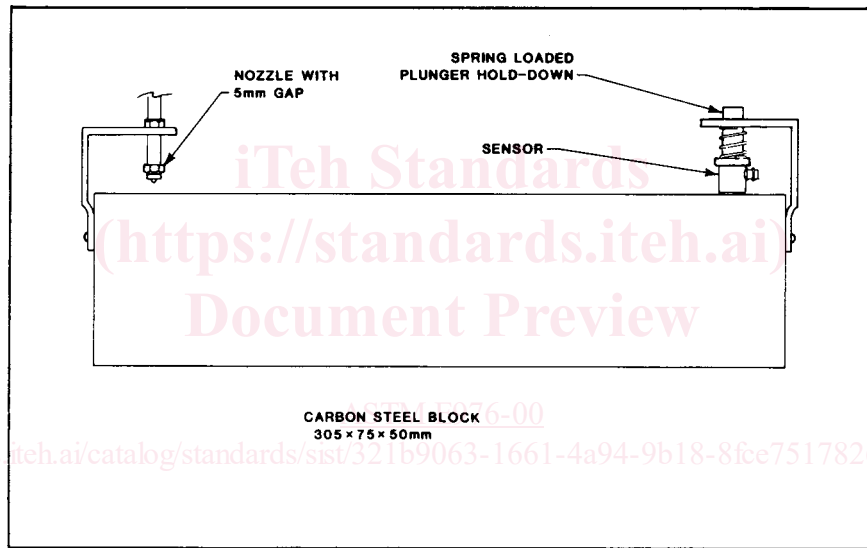

(b) Same Surface Comparison Test

FIG. 3 Gas-Jet Test Blocks

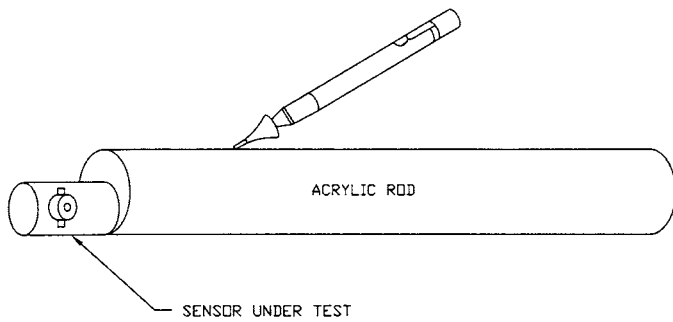

FIG. 4 Acrylic Polymer Rod

between 2 and 3 mm are preferred).² The lead should always be broken at the same spot on the block or rod with the same angle and orientation of the pencil. Spacing between the lead break and sensor should be at least 10 cm (4 in.). With distances shorter than that, it is harder to get consistent results. The most desirable permanent record of a pencil lead break is the wave form captured by a transient recorder or oscilloscope.

4.4 *Measuring and Recording Equipment*— The output of the sensor under test must be amplified before it can be measured. After the measurement, the results should be stored in a form that allows an easy comparison, either with another sensor or with the same sensor at a different time.

breaking the lead consistently. Care should be taken to always break the same length of the same type of lead (lengths

² Pentel 2H lead has been found satisfactory for this purpose.