**Paints and varnishes — Determination
of percentage volume of non-volatile
matter —**

Part 1:
**Method using a coated test panel to
determine non-volatile matter and
to determine dry-film density by the
Archimedes' principle**

*Peintures et vernis — Détermination du pourcentage en volume de
matière non volatile —*

*Partie 1: Méthode utilisant un panneau d'essai revêtu pour
déterminer la matière non volatile et pour déterminer la masse
volumique du feuil sec par le principe d'Archimède*



iTeh Standards
(<https://standards.iteh.ai>)
Document Preview

[ISO 3233-1:2019](https://standards.iteh.ai/catalog/standards/iso/42eeac02-4093-4dc8-a5c9-200c51ec0bb0/iso-3233-1-2019)

<https://standards.iteh.ai/catalog/standards/iso/42eeac02-4093-4dc8-a5c9-200c51ec0bb0/iso-3233-1-2019>



COPYRIGHT PROTECTED DOCUMENT

© ISO 2019

All rights reserved. Unless otherwise specified, or required in the context of its implementation, no part of this publication may be reproduced or utilized otherwise in any form or by any means, electronic or mechanical, including photocopying, or posting on the internet or an intranet, without prior written permission. Permission can be requested from either ISO at the address below or ISO's member body in the country of the requester.

ISO copyright office
CP 401 • Ch. de Blandonnet 8
CH-1214 Vernier, Geneva
Phone: +41 22 749 01 11
Fax: +41 22 749 09 47
Email: copyright@iso.org
Website: www.iso.org

Published in Switzerland

Contents

Page

Foreword	iv
Introduction	v
1 Scope	1
2 Normative references	1
3 Terms and definitions	1
4 Principle	2
5 Apparatus and reagents	2
6 Sampling	5
7 Procedure	5
7.1 Number of determinations and preparation.....	5
7.2 Choice of receptacle.....	5
7.3 Determination of volume of uncoated receptacle.....	5
7.4 Application.....	6
7.4.1 General.....	6
7.4.2 Discs.....	6
7.4.3 Plates.....	6
7.4.4 Drying.....	7
7.5 Determination of volume of dry coating.....	7
7.6 Determination of density of the liquid coating material.....	7
8 Calculation	7
8.1 Calculation of the practical dry-film density, non-volatile-matter content and non-volatile matter by volume.....	7
8.2 Calculation of the spreading rate.....	8
9 Precision	9
9.1 Repeatability limit.....	9
9.2 Reproducibility limit.....	9
10 Test report	9
Annex A (informative) Examples of test conditions	10
Annex B (informative) Overview of the existing methods for determination of non-volatile-matter content and volume of non-volatile matter	11
Bibliography	13

Foreword

ISO (the International Organization for Standardization) is a worldwide federation of national standards bodies (ISO member bodies). The work of preparing International Standards is normally carried out through ISO technical committees. Each member body interested in a subject for which a technical committee has been established has the right to be represented on that committee. International organizations, governmental and non-governmental, in liaison with ISO, also take part in the work. ISO collaborates closely with the International Electrotechnical Commission (IEC) on all matters of electrotechnical standardization.

The procedures used to develop this document and those intended for its further maintenance are described in the ISO/IEC Directives, Part 1. In particular, the different approval criteria needed for the different types of ISO documents should be noted. This document was drafted in accordance with the editorial rules of the ISO/IEC Directives, Part 2 (see www.iso.org/directives).

Attention is drawn to the possibility that some of the elements of this document may be the subject of patent rights. ISO shall not be held responsible for identifying any or all such patent rights. Details of any patent rights identified during the development of the document will be in the Introduction and/or on the ISO list of patent declarations received (see www.iso.org/patents).

Any trade name used in this document is information given for the convenience of users and does not constitute an endorsement.

For an explanation of the voluntary nature of standards, the meaning of ISO specific terms and expressions related to conformity assessment, as well as information about ISO's adherence to the World Trade Organization (WTO) principles in the Technical Barriers to Trade (TBT), see www.iso.org/iso/foreword.html.

This document was prepared by Technical Committee ISO/TC 35, *Paints and varnishes*, Subcommittee SC 9, *General test methods for paints and varnishes*.

This second edition cancels and replaces the first edition (ISO 3233-1:2013), which has been technically revised.

The main changes compared to the previous edition are as follows:

- the definitions and sources have been updated in [Clause 3](#);
- a minimum mass of 25 mg of the coating on the plate has been added in [7.4.1](#) because measurements and simulation calculations demonstrate the need for a minimum mass for the coated panel;
- the text has been editorially revised.

A list of all parts in the ISO 3233 series can be found on the ISO website.

Any feedback or questions on this document should be directed to the user's national standards body. A complete listing of these bodies can be found at www.iso.org/members.html.

Introduction

This method is used to measure the density and to determine the volume of a dry coating obtainable from a given volume of liquid paint. This volume is considered to be the most meaningful measure of the coverage (area of surface covered at a specified dry-film thickness per unit volume) of a paint, varnish or related product. The value obtained by this method might not be the same as that calculated on the basis of the addition of masses and volumes of the raw materials in a formulation. The volume occupied by a combination of resin and solvent can be the same as, greater than or less than the combined volume of the separate components, due to contraction or expansion of the resin and solvent. A second factor affecting the volume of a dry coating formulation is the degree to which the spaces between pigment particles are filled with binder. A third factor is the use of volatile components in reactive systems that, by their reaction, change into non-volatile film-building materials, i.e. amines and reactive solvents in high-build two-component coating materials.

Above and close to the critical pigment volume concentration, the volume of a dry paint film is greater than the theoretical volume, due to an increase in unfilled voids between pigment particles. The porosity of the film means that this method is unsuitable.

The values obtained for the non-volatile matter by volume are dependent on the temperature and time of heating, and these conditions should be carefully considered for the material being tested.

iTeh Standards (<https://standards.iteh.ai>) Document Preview

[ISO 3233-1:2019](https://standards.iteh.ai/catalog/standards/iso/42eeac02-4093-4dc8-a5c9-200c51ec0bb0/iso-3233-1-2019)

<https://standards.iteh.ai/catalog/standards/iso/42eeac02-4093-4dc8-a5c9-200c51ec0bb0/iso-3233-1-2019>

Paints and varnishes — Determination of percentage volume of non-volatile matter —

Part 1:

Method using a coated test panel to determine non-volatile matter and to determine dry-film density by the Archimedes' principle

1 Scope

This document specifies a method for determining the non-volatile matter by volume (NV_v) of coating materials and related products by measuring the density of a dried coating for any specified temperature range and period of drying or curing. This method determines the non-volatile matter immediately after application.

Using the non-volatile matter by volume results obtained in accordance with this document, it is possible to calculate the spreading rate of coating materials.

The method specified in this document is the preferred method for air-drying materials. Its use for other materials has not yet been tested.

[Annex B](#) gives an overview of the existing methods for determination of non-volatile-matter content and volume of non-volatile matter.

This document is not applicable to coating materials in which the critical pigment volume concentration is exceeded.

[ISO 3233-1:2019](#)

<https://standards.iteh.ai/catalog/standards/iso/42eeac02-4093-4dc8-a5c9-200c51ec0bb0/iso-3233-1-2019>

2 Normative references

The following documents are referred to in the text in such a way that some or all of their content constitutes requirements of this document. For dated references, only the edition cited applies. For undated references, the latest edition of the referenced document (including any amendments) applies.

ISO 1513, *Paints and varnishes — Examination and preparation of test samples*

ISO 2811 (all parts), *Paints and varnishes — Determination of density*

ISO 4618, *Paints and varnishes — Terms and definitions*

ISO 15528, *Paints, varnishes and raw materials for paints and varnishes — Sampling*

3 Terms and definitions

For the purposes of this document, the terms and definitions given in ISO 4618 and the following apply.

ISO and IEC maintain terminological databases for use in standardization at the following addresses:

- ISO Online browsing platform: available at <https://www.iso.org/obp>
- IEC Electropedia: available at <http://www.electropedia.org/>

3.1
non-volatile matter
NV

residue by mass obtained by evaporation under specified conditions

Note 1 to entry: Instead of the term “non-volatile matter” different terms, such as solid, dry residue, dry matter, solid matter, stoving residue are being used commonly with the respective abbreviations. The term “non-volatile matter” which is also applied in ISO 3251 should be used together with the abbreviation “NV” instead of these terms.

Note 2 to entry: This document and ISO 3251 specify different conditions for the determination of NV. Therefore, in this document, the symbol NV_m is used for non-volatile matter by mass.

[SOURCE: ISO 4618:2014, 2.176 modified — Note 2 to entry added.]

3.2
non-volatile matter by volume
 NV_v

percentage residue by volume obtained by evaporation under specified conditions

3.3
spreading rate
s

surface area that can be covered by a given quantity of coating material to give a dried film of requisite thickness

Note 1 to entry: It is expressed in m^2/l or m^2/kg .

[SOURCE: ISO 4618:2014, 2.238 — modified, symbol s added and Note 2 to entry deleted.]

3.4
practical dry-film density

ρ_p
practically determined density of a dried and cured coating

4 Principle

A receptacle (disc or plate) is weighed in air and in water (or other suitable liquid of known density), coated with the product to be tested, dried and reweighed in air and in the same liquid. From these measurements, the mass, the volume and hence the density of the dry coating are calculated. The non-volatile matter by volume is calculated from the quotient of the density of the coating material and the density of the dry film.

5 Apparatus and reagents

Standard laboratory apparatus, together with the following:

5.1 Analytical balance, accurate to 0,1 mg.

A single-pan balance is most convenient, and a useful modification is to replace the balance pan by a standard counterweight attachment as shown in [Figure 1](#).

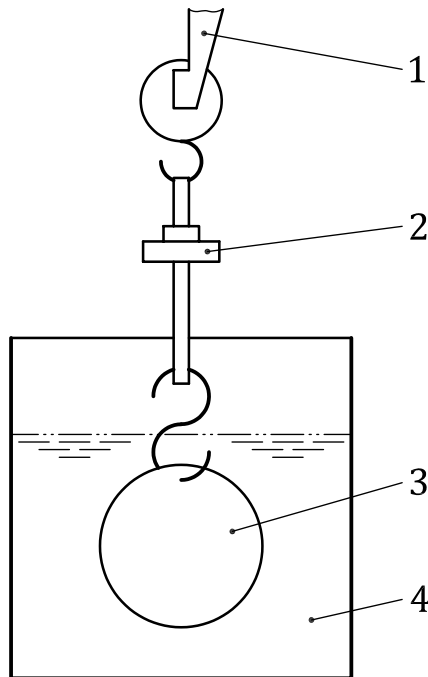
**Key**

- 1 balance arm
- 2 standard counterweight attachment
- 3 disc
- 4 immersion liquid

Figure 1 — Special balance support**5.2 Receptacle** (see 7.2).

ISO 3233-1:2019

<https://standards.iteh.ai/catalog/standards/iso/42eeac02-4093-4dc8-a5c9-200c51ec0bb0/iso-3233-1-2019>

5.2.1 Disc, about 60 mm in diameter and about 0,7 mm thick, with a small hole at least 2 mm to 3 mm from the edge.

A stainless-steel disc has been found satisfactory but has the disadvantage of having a density much in excess of normal liquid coatings. Discs of lighter material, including plastics, for example poly(ethylene terephthalate), are permitted, provided they do not change in volume by contact with the solvents contained in the liquid coating, or during the heating and drying processes involved.

5.2.2 Plate, of size (75 ± 5) mm by (120 ± 5) mm, with a small hole at least 2 mm to 3 mm from the shorter side on the longitudinal axis of the panel.

Glass plates may be used as these are very flat. However, drilling a hole is difficult and therefore, if glass plates are used, they should preferably be suspended in a stirrup or cradle of thin wire (see Figure 2). The diameter of the wire shall not exceed 0,3 mm because of surface tension effects.

Plates of this size might be difficult to accommodate in a balance case. Smaller plates may therefore be used provided the coated area is no less than 5 600 mm².

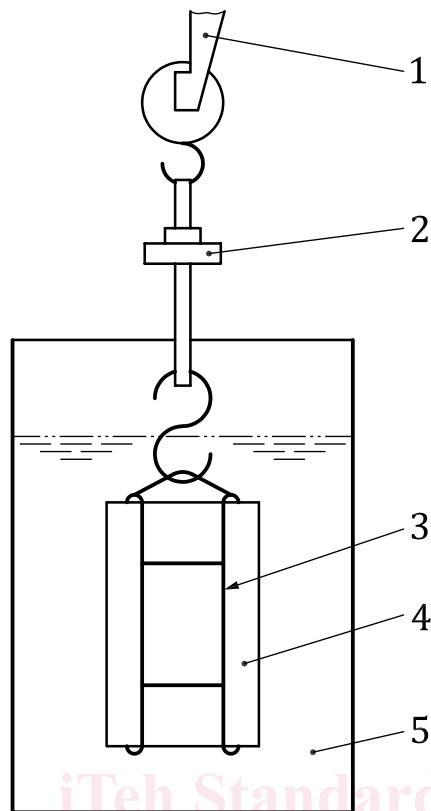

Key

- 1 balance arm
- 2 standard counterweight attachment
- 3 wire cradle
- 4 plate
- 5 immersion liquid

(<https://standards.iteh.ai>)
Document Preview

ISO 3233-1:2019

<https://standards.iteh.ai/catalog/standards/iso/42eeac02-4093-4dc8-a5c9-200c51ec0bb0/iso-3233-1-2019>

Figure 2 — Wire cradle support for plate

5.3 Hook, made of stainless steel or synthetic thread, for attaching the receptacle to the balance during weighing operations. The diameter of the wire shall not exceed 0,3 mm because of surface tension effects.

5.4 Beaker, of size convenient for immersing the receptacle with a clearance of at least 10 mm and which can be accommodated in the balance case.

5.5 Support, for holding the beaker under the balance stirrup without jamming the pan damper, if a counterweight as recommended in [5.1](#) is not available.

5.6 Immersion liquid, of suitable density, in which the receptacle is immersed.

Distilled water is suitable for most coating materials. An organic liquid which does not affect the paint film may also be used.

5.7 Desiccator, containing a suitable desiccant.