



SLOVENSKI STANDARD

oSIST prEN 12790-1:2023

01-november-2023

Izdelki za otroke - Sklopne zibelke - 1. del: Sklopne zibelke za otroke, ki še ne poskušajo sedeti

Child care articles - Reclined cradles and infant swings - Part 1: Reclined cradles and infant swings for children up to when they start to try to sit up

Artikel für Säuglinge und Kleinkinder - Kinderliegesitze - Teil 1: Kinderliegesitze für Kinder bis sie versuchen, sich aufzusetzen

Articles de puériculture - Transats et balancelles suspendues pour enfants - Partie 1 : Transats et balancelles suspendues pour enfants jusqu'à ce qu'ils commencent à essayer de s'asseoir

Ta slovenski standard je istoveten z: prEN 12790-1

<https://standards.iteh.ai/catalog/standards/sist/5a930edc-91e8-44c7-9976-22e2f4654bc2/osist-pren-12790-1-2023>

ICS:

97.190

Otroška oprema

Equipment for children

oSIST prEN 12790-1:2023

en,fr,de

EUROPEAN STANDARD
NORME EUROPÉENNE
EUROPÄISCHE NORM

DRAFT
prEN 12790-1

September 2023

ICS

Will supersede EN 12790-1:2023, EN
16232:2013+A2:2023

English Version

Child care articles - Reclined cradles and infant swings - Part 1: Reclined cradles and infant swings for children up to when they start to try to sit up

Artikel für Säuglinge und Kleinkinder ζ
Kinderliegesitze ζ Teil 1: Kinderliegesitze für Kinder
bis sie versuchen, sich aufzusetzen

This draft European Standard is submitted to CEN members for enquiry. It has been drawn up by the Technical Committee CEN/TC 252.

If this draft becomes a European Standard, CEN members are bound to comply with the CEN/CENELEC Internal Regulations which stipulate the conditions for giving this European Standard the status of a national standard without any alteration.

This draft European Standard was established by CEN in three official versions (English, French, German). A version in any other language made by translation under the responsibility of a CEN member into its own language and notified to the CEN-CENELEC Management Centre has the same status as the official versions.

CEN members are the national standards bodies of Austria, Belgium, Bulgaria, Croatia, Cyprus, Czech Republic, Denmark, Estonia, Finland, France, Germany, Greece, Hungary, Iceland, Ireland, Italy, Latvia, Lithuania, Luxembourg, Malta, Netherlands, Norway, Poland, Portugal, Republic of North Macedonia, Romania, Serbia, Slovakia, Slovenia, Spain, Sweden, Switzerland, Türkiye and United Kingdom.

Recipients of this draft are invited to submit, with their comments, notification of any relevant patent rights of which they are aware and to provide supporting documentation.

Warning : This document is not a European Standard. It is distributed for review and comments. It is subject to change without notice and shall not be referred to as a European Standard.



EUROPEAN COMMITTEE FOR STANDARDIZATION
COMITÉ EUROPÉEN DE NORMALISATION
EUROPÄISCHES KOMITEE FÜR NORMUNG

CEN-CENELEC Management Centre: Rue de la Science 23, B-1040 Brussels

Contents	Page
European foreword	4
1 Scope.....	5
2 Normative references.....	5
3 Terms and definitions	6
4 Test equipment.....	7
4.1 Test mass A.....	7
4.2 Test mass B.....	8
4.3 Test mass C.....	8
4.4 Test mass D	9
4.5 Small parts cylinder	9
4.6 Feeler gauge.....	10
4.7 Test probes for finger entrapment.....	10
4.8 Test equipment for handle strength test.....	12
4.9 Test equipment for handle locking mechanism strength test.....	15
4.10 Test surface for the stability test.....	16
4.11 Test surface for static slippage	16
4.12 Impactor.....	16
4.13 Test equipment for sound level measurement.....	17
5 General requirements and test conditions.....	17
5.1 Product conditioning.....	17
5.2 Test conditions	17
5.3 Application of forces	17
5.4 Tolerances	18
5.5 Order of tests	18
6 Chemical hazards.....	18
6.1 General.....	18
6.2 Migration of certain elements (see A.2)	18
6.3 Formaldehyde (see A.2).....	19
6.4 Colourants (see A.2).....	19
6.5 Aniline (see A.2)	20
7 Thermal hazards	20
7.1 Requirements.....	20
7.2 Test method	20
8 Mechanical hazards.....	20
8.1 General.....	20
8.2 Hazards due to sound level	25
8.3 Entrapment hazards	26
8.4 Hazards due to moving parts.....	26
8.5 Hazards due to falling of the child	26
8.6 Hazards due to folding of the product.....	37
8.7 Hazards from entanglement in cords, ribbons and similar parts.....	38
8.8 Choking and ingestion hazard.....	39
8.9 Suffocation hazards from plastic packaging	40

8.10	Hazards from edges, corners and protruding parts.....	40
8.11	Hazards from inadequate structural integrity.....	40
8.12	Hazards from inadequate stability.....	46
8.13	Hazards from possible slippage of the reclined cradle.....	47
8.14	Electrical hazards	48
9	Product information.....	49
9.1	General	49
9.2	Marking of the product.....	49
9.3	Purchase information	51
9.4	Instructions for use.....	52
	Annex A (informative) Rationales	54
A.1	Introduction	54
A.2	Chemical hazards (see Clause 6)	54
A.3	Thermal hazards (see Clause 7)	55
A.4	Mechanical hazards (see Clause 8).....	55
	Annex B (normative) Warnings.....	58
	Annex C (informative) A-deviations.....	73
	Annex ZA (informative) Relationship between this European Standard and the safety requirements of Directive 2001/95/EC aimed to be covered.....	74
	Bibliography	77

Itih Standards
(<https://standards.iteh.ai>)
Document Preview

[oSIST prEN 12790-1:2023](https://standards.iteh.ai/catalog/standards/sist/5a930edc-91e8-44c7-9976-22e2f4654bc2/osist-pren-12790-1-2023)

<https://standards.iteh.ai/catalog/standards/sist/5a930edc-91e8-44c7-9976-22e2f4654bc2/osist-pren-12790-1-2023>

prEN 12790-1:2023 (E)**European foreword**

This document (prEN 12790-1:2023) has been prepared by Technical Committee CEN/TC 252 “Child care articles”, the secretariat of which is held by AFNOR.

This document is currently submitted to the CEN Enquiry.

This document will supersede EN 12790-1:2023 and EN 16232:2013+A2:2023.

prEN 12790-1:2023 includes the following significant technical changes with respect to EN 12790-1:2023 and EN 16232:2013+A2:2023:

- merge in one single standard of the two previous standards covering reclined cradles (EN 12790-1:2023) and infant swings (EN 16232:2013+A2:2023);
- harmonization of the requirements for the two product categories as relevant;
- general update of the normative references;
- general update of the requirements to the state-of-the-art.

This document has been prepared under a Standardization Request given to CEN by the European Commission and the European Free Trade Association, and supports essential requirements of EU Directive(s) / Regulation(s).

For relationship with EU Directive(s) / Regulation(s), see informative Annex ZA which is an integral part of this document.

iteh Standards
(<https://standards.iteh.ai>)
Document Preview

[oSIST prEN 12790-1:2023](https://standards.iteh.ai/catalog/standards/sist/5a930edc-91e8-44c7-9976-22e2f4654bc2/osist-pren-12790-1-2023)

<https://standards.iteh.ai/catalog/standards/sist/5a930edc-91e8-44c7-9976-22e2f4654bc2/osist-pren-12790-1-2023>

1 Scope

This document specifies safety requirements and the corresponding test methods for fixed or folding reclined cradles and infant swings intended for children up to when they start to try to sit up.

This document applies also to car seats complying with UN R44 or UN R129 that can be used as reclined cradles according to manufacturer's instructions. If usage as reclined cradle is not included in the product information or marketing material, car seats are excluded from the scope of this document.

If a reclined cradle or infant swing has several functions or can be converted into another function the relevant European standards apply to it.

Swings falling under the scope of EN 71-8 are excluded from the scope of this European Standard.

NOTE For the rest of the document, the word "product" will be used when referring at the same time to reclined cradles and infant swings.

2 Normative references

The following documents are referred to in the text in such a way that some or all of their content constitutes requirements of this document. For dated references, only the edition cited applies. For undated references, the latest edition of the referenced document (including any amendments) applies.

EN 12790-2:2022, *Child care articles — Reclined cradles — Part 2: Reclined cradles for children up to when they start to stand up*

EN 71-2:2020, *Safety of toys - Part 2: Flammability*

EN 71-3:2019+A1:2021, *Safety of toys - Part 3: Migration of certain elements*

EN 71-10:2005, *Safety of toys - Part 10: Organic chemical compounds - Sample preparation and extraction*

EN 71-11:2005, *Safety of toys - Part 11: Organic chemical compounds - Methods of analysis*

EN 622-1:2003, *Fibreboards - Specifications - Part 1: General requirements*

EN 717-1:2004, *Wood-based panels - Determination of formaldehyde release - Part 1: Formaldehyde emission by the chamber method*

EN ISO 105-A03:2019, *Textiles - Tests for colour fastness - Part A03: Grey scale for assessing staining (ISO 105-A03:2019)*

EN 61558-2-7:2007, *Safety of power transformers, power supplies, reactors and similar products - Part 2-7: Particular requirements and tests for transformers and power supplies for toys*

EN 61558-2-16:2009+A1:2013, *Safety of transformers, reactors, power supply units and similar products for supply voltages up to 1 100 V - Part 2-16: Particular requirements and tests for switch mode power supply units and transformers for switch mode power supply units*

EN 61672-1:2013, *Electroacoustics - Sound level meters - Part 1: Specifications*

EN IEC 62115:2020+A11:2020, *Electric toys – Safety*

EN ISO 3746:2010, *Acoustics - Determination of sound power levels and sound energy levels of noise sources using sound pressure - Survey method using an enveloping measurement surface over a reflecting plane (ISO 3746:2010)*

prEN 12790-1:2023 (E)

EN ISO 14184-1:2011, *Textiles - Determination of formaldehyde - Part 1: Free and hydrolysed formaldehyde (water extraction method) (ISO 14184-1:2011)*

EN ISO 14362-1:2017, *Textiles - Methods for determination of certain aromatic amines derived from azo colorants - Part 1: Detection of the use of certain azo colorants accessible with and without extracting the fibres (ISO 14362-1:2017)*

EN ISO 17234-1:2020, *Leather - Chemical tests for the determination of certain azo colourants in dyed leathers - Part 1: Determination of certain aromatic amines derived from azo colorants (ISO 17234-1:2020)*

ISO 48-4:2018, *Rubber, vulcanized or thermoplastic — Determination of hardness — Part 4: Indentation hardness by durometer method (Shore hardness)*

3 Terms and definitions

For the purposes of this document, the following terms and definitions apply.

ISO and IEC maintain terminology databases for use in standardization at the following addresses:

- ISO Online browsing platform: available at <https://www.iso.org/obp/>
- IEC Electropedia: available at <https://www.electropedia.org/>

3.1**reclined cradle**

article with a frame that supports a seat unit that accommodates a child in a reclined position, with or without a mechanism that enables the child to be moved in any direction (i.e. front to back, side to side, arc, etc.)

Note 1 to entry: The seat unit is supported by the frame and not suspended from it.

Note 2 to entry: Reclined cradles may be static, rocking, bouncing or gliding and may have an adjustable backrest and/or seat, see A.1.

3.2**infant swing**

article with a frame, a seat unit suspended from above and a mechanism that enables a child in a reclined position to be moved in any direction relative to the frame (i.e., front to back, side to side, arc, etc.)

3.3**seat unit**

part of the product that supports the child, either in the form of a hammock or composed by a seat and a backrest

3.4**restraint system**

system to restrain the child within the product

3.5**crotch restraint**

device designed to pass between the child's legs to prevent the child from sliding forward

3.6**carrying handle**

component to enable the product, with the child in it, to be carried by hand

3.7**junction line**

intersection of the seat and the backrest

3.8**toy bar**

any bar or mobile connected to the frame of the product in any location with one or more attachment points typically used to suspend toys over the occupant

Note 1 to entry: Canopies and carrying handles, fixed and rotating, are not considered a toy bar regardless of whether they allow for the attachment of toys.

4 Test equipment**4.1 Test mass A**

Test mass A is a rigid cylinder (160 ± 5) mm in diameter and (300 ± 5) mm in height, having a mass of $9_0^{+0,01}$ kg and with its centre of gravity in the centre of the cylinder. All edges shall have a radius of (5 ± 1) mm. Two anchorage points shall be provided. These shall be positioned ($150 \pm 2,5$) mm from the base and at 180° to each other around the circumference (see Figure 1).

Dimensions in millimetres

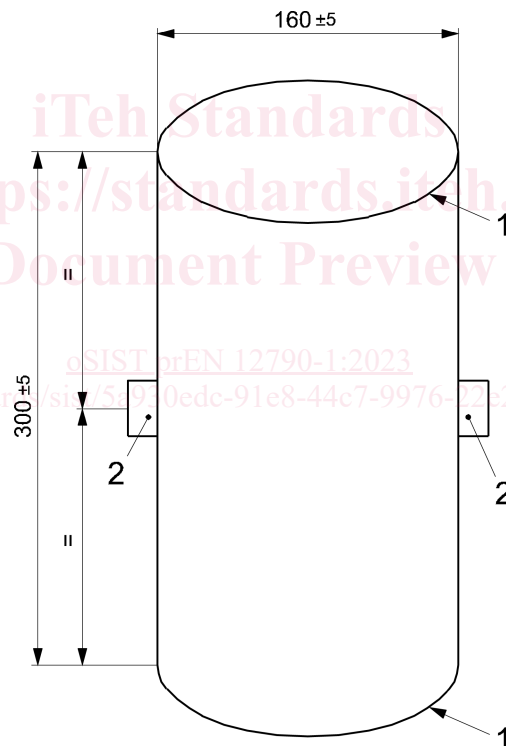
**Key**

- 1 radius: (5 ± 1) mm
- 2 two anchorage points

Figure 1 — Test mass A

prEN 12790-1:2023 (E)**4.2 Test mass B**

Test mass B is a rigid cylinder (200 ± 5) mm in diameter and (300 ± 5) mm in height, having a mass of $15^{+0,01}_0$ kg and with its centre of gravity in the centre of the cylinder. All edges shall have a radius of (5 ± 1) mm. Two anchorage points shall be provided. These shall be positioned $(150 \pm 2,5)$ mm from the base and at 180° to each other around the circumference (see Figure 2).

Dimensions in millimetres

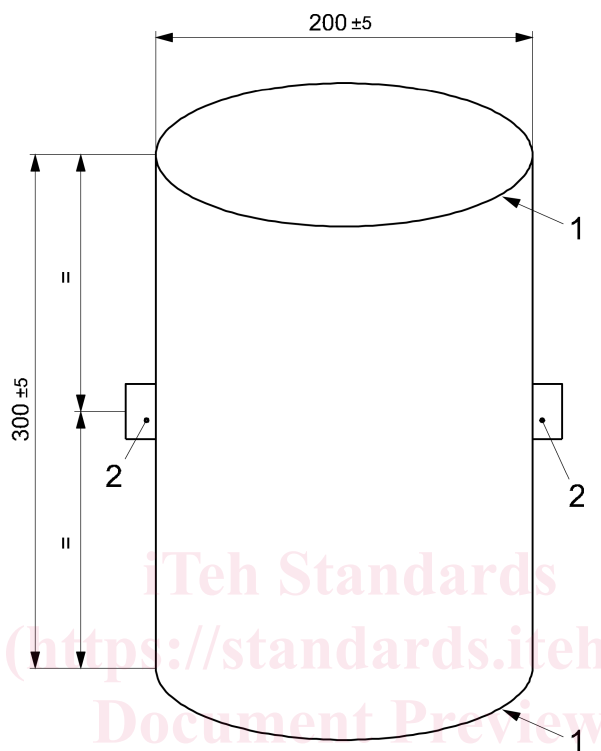
**Key**

- 1 radius: (5 ± 1) mm
- 2 two anchorage points

Figure 2 — Test mass B

4.3 Test mass C

An object made of steel with a total mass of $(9 \pm 0,1)$ kg and with dimensions as specified in Figure 3. All edges shall be rounded or chamfered.

Dimensions in millimetres

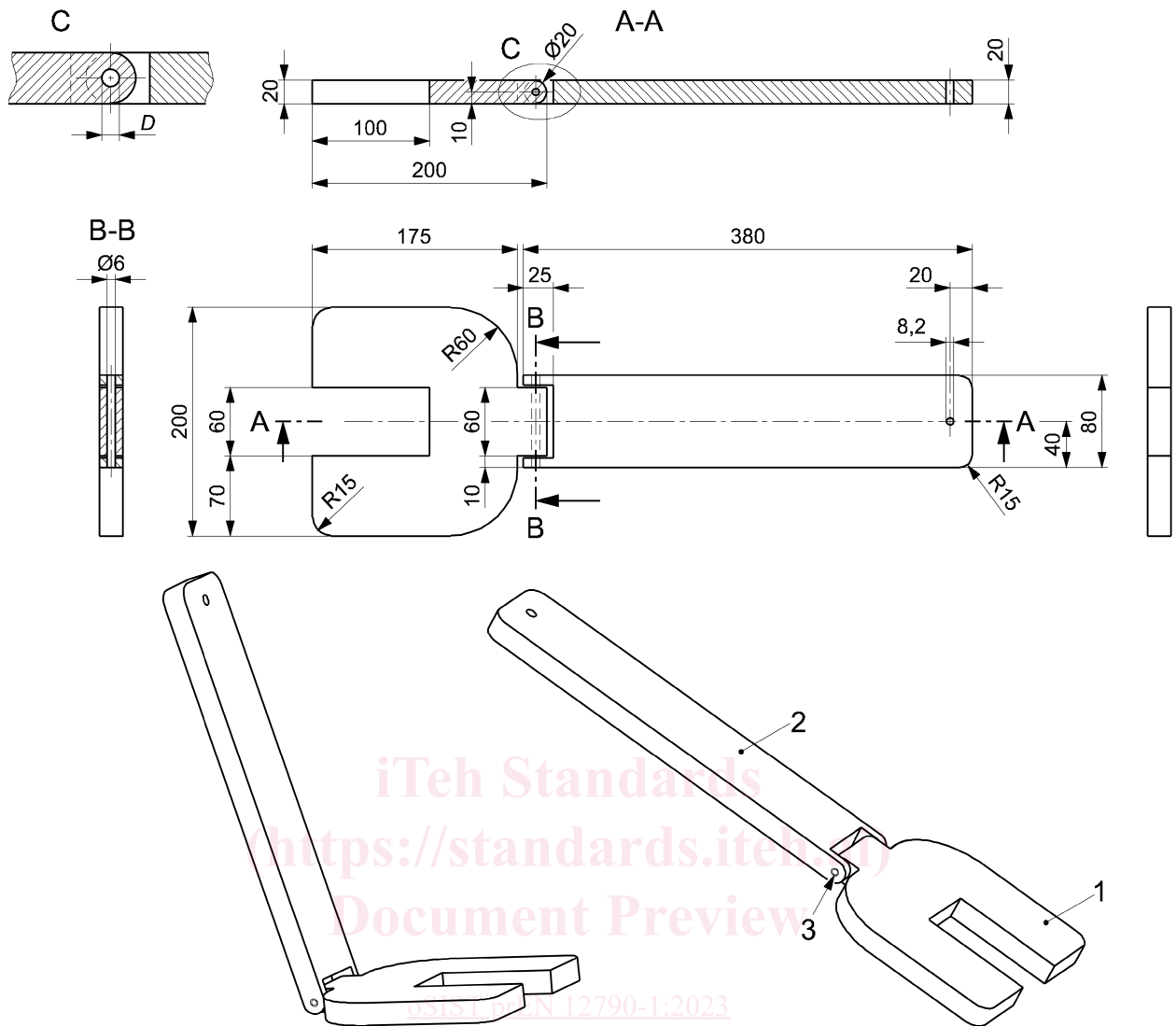
**Key**

- 1 seat part [mass: $(4,495 \pm 0,05)$ kg]
 - 2 backrest part [mass: $(4,501 \pm 0,05)$ kg]
 - 3 hinge pin made of steel [mass of hinge pin: $(17 \pm 0,5)$ g, length: 79,5 mm]
- D diameter: 6 mm
Dimensions tolerance: ± 2 mm

Figure 3 — Test mass C**4.4 Test mass D**

Test mass D is a (150 ± 30) mm by (200 ± 30) mm rectangular shaped sand bag with a mass of $(3 \pm 0,1)$ kg.

4.5 Small parts cylinder

Small parts cylinder for the assessment of small components, having dimensions in accordance with Figure 4.

Dimension in millimetres

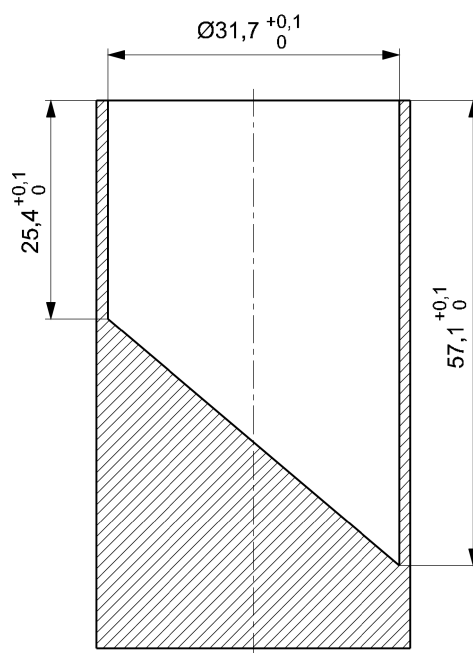

Figure 4 — Small parts cylinder

4.6 Feeler gauge

Gauge with a thickness of $(0,4 \pm 0,02)$ mm and an insertion edge radius of $(3 \pm 0,5)$ mm (see Figure 5).

Dimensions in millimetres

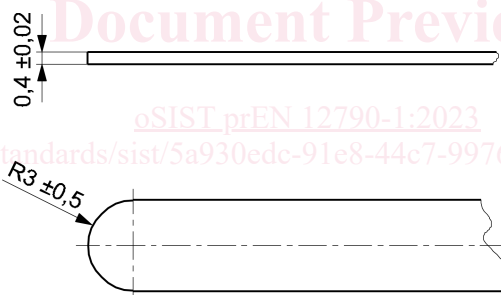

Figure 5 — Feeler gauge

4.7 Test probes for finger entrapment

4.7.1 Test probes with hemispherical end

Probes made from plastic or other hard, smooth material of diameters $7_{-0,1}^0$ mm and $12_0^{+0,1}$ mm with a full hemispherical end that can be mounted on a force-measuring device, see Figure 6.

Dimensions in millimetres

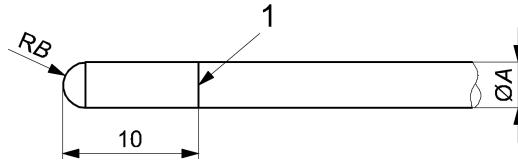
**Key**

Probe type	7 mm probe	12 mm probe
Diameter A	$7_{-0,1}^0$	$12_{0}^{+0,1}$
Radius RB	half of diameter A	half of diameter A
1	Line ascribed around circumference showing depth of penetration	

Figure 6 — Test probes with hemispherical end**4.7.2 Test probe for mesh**

Mesh probe made from plastic or other hard, smooth material as shown in Figure 7.

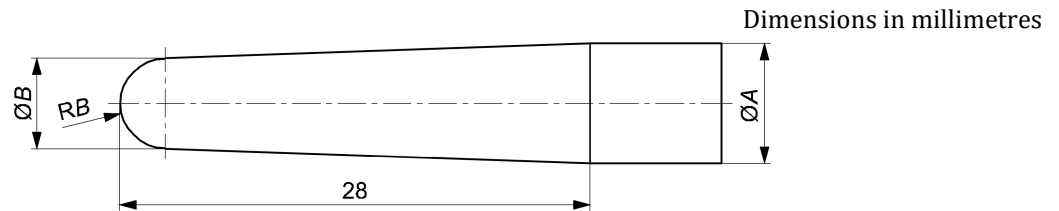
**Key**

Probe type	mesh probe
Diameter A	$7_{-0,1}^0$
Diameter B	$5,6_{-0,1}^0$
Radius RB	half of diameter B

Figure 7 — Test probe for mesh**4.7.3 Shape assessment probe**

Probe made from plastic or other hard, smooth material with the dimensions shown in Figure 8.

prEN 12790-1:2023 (E)

Dimensions in millimetres

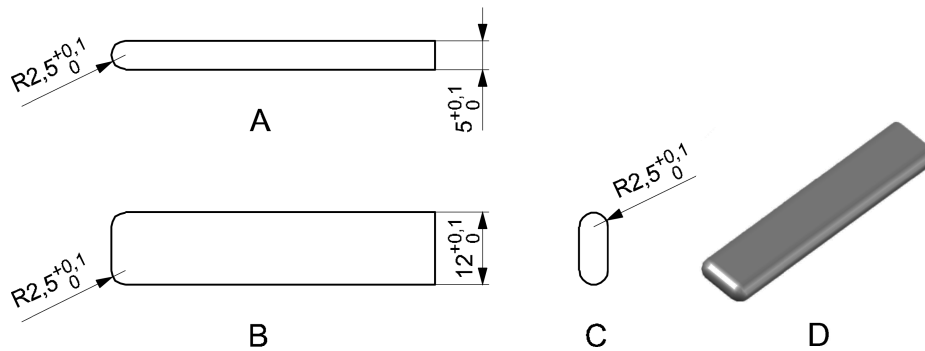
**Key**

- A front view
- B top view
- C side view
- D 3D view

Figure 8 — Shape assessment probe**4.8 Test equipment for handle strength test**

Hooks rigidly connected to a metal plate (see Figure 9).

The distance between the central axis of two hooks shall be (70 ± 2) mm (see Figure 9).

(<https://standards.iteh.ai>)
Document Preview

[oSIST prEN 12790-1:2023](https://standards.iteh.ai/catalog/standards/sist/5a930edc-91e8-44c7-9976-22e2f4654bc2/osist-pren-12790-1-2023)

<https://standards.iteh.ai/catalog/standards/sist/5a930edc-91e8-44c7-9976-22e2f4654bc2/osist-pren-12790-1-2023>