**Aerospace — Blind fasteners,
threaded type, self-locking — Test
method for locking torque**

*Aéronautique et espace — Éléments de fixation borgnes, type fileté, à
freinage interne — Méthode d'essai de couple de freinage*

iTeh STANDARD PREVIEW
(standards.iteh.ai)

[ISO 23887:2021](https://standards.iteh.ai/catalog/standards/sist/fc825ade-c303-44c5-b4a4-7c2ee0bc88bd/iso-23887-2021)

<https://standards.iteh.ai/catalog/standards/sist/fc825ade-c303-44c5-b4a4-7c2ee0bc88bd/iso-23887-2021>



iTeh STANDARD PREVIEW (standards.iteh.ai)

[ISO 23887:2021](https://standards.iteh.ai/catalog/standards/sist/fc825ade-c303-44c5-b4a4-7c2ee0bc88bd/iso-23887-2021)

<https://standards.iteh.ai/catalog/standards/sist/fc825ade-c303-44c5-b4a4-7c2ee0bc88bd/iso-23887-2021>



COPYRIGHT PROTECTED DOCUMENT

© ISO 2021

All rights reserved. Unless otherwise specified, or required in the context of its implementation, no part of this publication may be reproduced or utilized otherwise in any form or by any means, electronic or mechanical, including photocopying, or posting on the internet or an intranet, without prior written permission. Permission can be requested from either ISO at the address below or ISO's member body in the country of the requester.

ISO copyright office
CP 401 • Ch. de Blandonnet 8
CH-1214 Vernier, Geneva
Phone: +41 22 749 01 11
Email: copyright@iso.org
Website: www.iso.org

Published in Switzerland

Contents

	Page
Foreword	iv
1 Scope	1
2 Normative references	1
3 Terms and definitions	1
4 General requirements	2
4.1 Test apparatus	2
4.1.1 Torque wrenches	2
4.1.2 Torsion machines	2
4.2 Test fixture	2
5 Detail requirements	3
5.1 Test procedures	3
5.2 Experiment data processing	3
5.3 Test reports	4

iTeh STANDARD PREVIEW (standards.iteh.ai)

[ISO 23887:2021](https://standards.iteh.ai/catalog/standards/sist/fc825ade-c303-44c5-b4a4-7c2ee0bc88bd/iso-23887-2021)

<https://standards.iteh.ai/catalog/standards/sist/fc825ade-c303-44c5-b4a4-7c2ee0bc88bd/iso-23887-2021>

Foreword

ISO (the International Organization for Standardization) is a worldwide federation of national standards bodies (ISO member bodies). The work of preparing International Standards is normally carried out through ISO technical committees. Each member body interested in a subject for which a technical committee has been established has the right to be represented on that committee. International organizations, governmental and non-governmental, in liaison with ISO, also take part in the work. ISO collaborates closely with the International Electrotechnical Commission (IEC) on all matters of electrotechnical standardization.

The procedures used to develop this document and those intended for its further maintenance are described in the ISO/IEC Directives, Part 1. In particular, the different approval criteria needed for the different types of ISO documents should be noted. This document was drafted in accordance with the editorial rules of the ISO/IEC Directives, Part 2 (see www.iso.org/directives).

Attention is drawn to the possibility that some of the elements of this document may be the subject of patent rights. ISO shall not be held responsible for identifying any or all such patent rights. Details of any patent rights identified during the development of the document will be in the Introduction and/or on the ISO list of patent declarations received (see www.iso.org/patents).

Any trade name used in this document is information given for the convenience of users and does not constitute an endorsement.

For an explanation of the voluntary nature of standards, the meaning of ISO specific terms and expressions related to conformity assessment, as well as information about ISO's adherence to the World Trade Organization (WTO) principles in the Technical Barriers to Trade (TBT), see www.iso.org/iso/foreword.html.

This document was prepared by Technical Committee ISO/TC 20, *Aircraft and space vehicles*, Subcommittee SC 4, *Aerospace fastener systems*. [ISO 23887:2021](https://standards.iteh.ai/catalog/standards/sist/fc825ade-c303-44c5-b4a4-7c301d81d/di-23887-102)

Any feedback or questions on this document should be directed to the user's national standards body. A complete listing of these bodies can be found at www.iso.org/members.html.

Aerospace — Blind fasteners, threaded type, self-locking — Test method for locking torque

1 Scope

This document describes the locking torque test method for blind fasteners, threaded type. This test method is used to measure the locking torque of blind fasteners with internal thread and external sleeve. It is applicable to blind fasteners consisting out of four elements (drive nut, nut, sleeve and corebolt) having a cross recess at the top of the nut.

2 Normative references

The following documents are referred to in the text in such a way that some or all of their content constitutes requirements of this document. For dated references, only the edition cited applies. For undated references, the latest edition of the referenced document (including any amendments) applies.

ISO 286-2, *Geometrical product specifications (GPS) — ISO code system for tolerances on linear sizes — Part 2: Tables of standard tolerance classes and limit deviations for holes and shafts*

ASME B107.300, *Torque Instruments (Mechanical)*

3 Terms and definitions

For the purposes of this document, the following terms and definitions apply.

ISO and IEC maintain terminological databases for use in standardization at the following addresses:

- ISO Online browsing platform: available at <https://www.iso.org/obp>
- IEC Electropedia: available at <https://www.electropedia.org/>

3.1

blind fastener, threaded type

fastener which can be installed from only one side with an internal thread and external sleeve

Note 1 to entry: A blind fastener which can be tested with this document shall consist of four elements: drive nut, nut (with a cross recess), sleeve and corebolt, see [Figure 1](#).

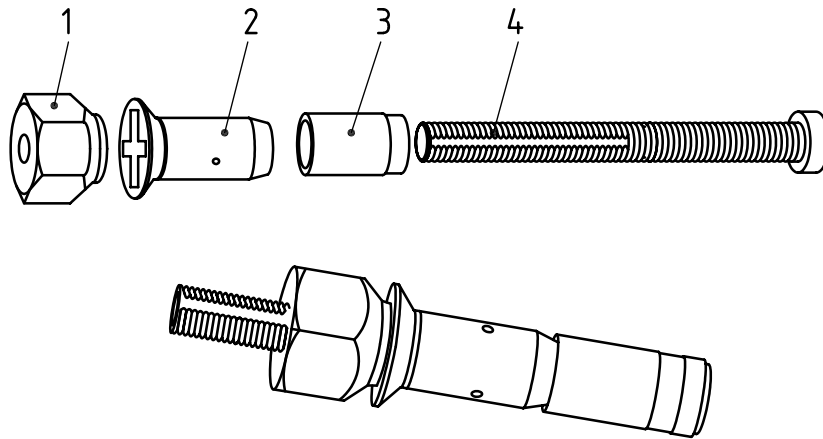

Key

- | | | | |
|---|-----------|---|----------|
| 1 | drive nut | 3 | sleeve |
| 2 | nut | 4 | corebolt |

Figure 1 — Blind fastener, threaded type

3.2 locking torque

torque to be measured between nut and corebolt under no axial load at disassembly process after the blind fastener is installed

ITeH STANDARD PREVIEW
(standards.iteh.ai)

4 General requirements

ISO 23887:2021

4.1 Test apparatus <https://standards.iteh.ai/catalog/standards/sist/fc825ade-c303-44c5-b4a4-7c2ee0bc88bd/iso-23887-2021>

4.1.1 Torque wrenches

Torque wrenches shall be in accordance with ASME B107.300, Type I, Class A. Torque wrenches shall have been calibrated within 12 months prior to the test. Torque wrenches shall have an accuracy of $\pm 4\%$. The torque indicating scale of the torque wrenches shall be selected so that indicated torque readings are within 20 % and 90 % of the scale capacity. If the torque values are not within the limits, the test shall be repeated using an appropriate scale.

4.1.2 Torsion machines

Torsion machines shall have been calibrated 12 months prior to the test. Torsion machines shall have an accuracy of $\pm 2\%$. The torque indicating scale of the Torsion machine shall be selected so that indicated torque readings are within 20 % and 90 % of the scale capacity. If the torque values are not within the limits, the test shall be repeated using an appropriate scale.

4.2 Test fixture

The blind fastener shall be installed on the test coupon with a specific thickness in accordance with the product specification. Installation hole size of test coupon shall be in accordance with the product specification. If the hole size is not given in the product specification the installation hole size shall be equal to the nominal fastener diameter, tolerance H11 in accordance with ISO 286-2.

A recommended test fixture is shown in [Figure 2](#).

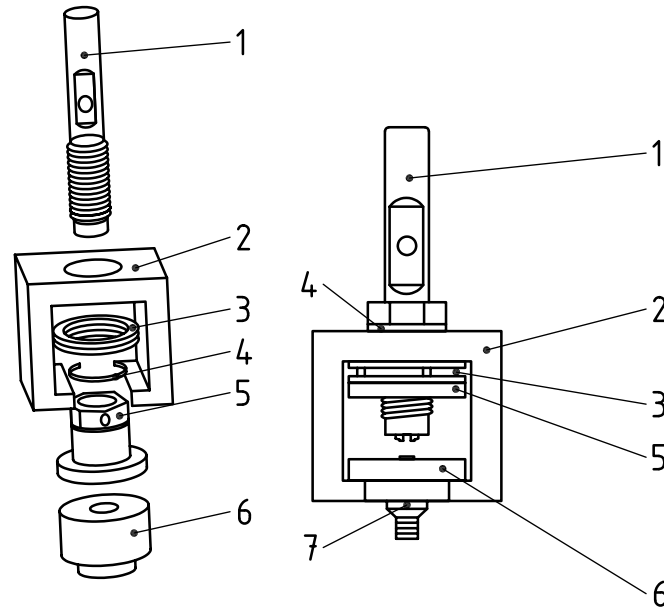
**Key**

- | | | | |
|---|---|---|-----------------------------|
| 1 | connecting rod bolt with a cross recess driver at the end | 5 | back nut |
| 2 | cradle | 6 | test coupon |
| 3 | bearing | 7 | blind fastener to be tested |
| 4 | retaining washer | | |

iTeh STANDARD PREVIEW

(standards.iteh.ai)

Figure 2 — Test fixture

ISO 23887:2021

<https://standards.iteh.ai/catalog/standards/sist/fc825ade-c303-44c5-b4a4-7c2ee0bc88bd/iso-23887-2021>

5 Detail requirements**5.1 Test procedures**

- Blind fastener with the required minimum relevant grip length shall be installed in accordance with the product specification until the fracture of corebolt; the blind side upset diameter shall exceed the minimum diameter, given in the product specification.
- Install the test coupon in the test fixture and fix the nut of the blind fastener with the connecting rod bolt in order to prevent it from rotating.
- Disassemble the blind fastener: test shall be run at a rate slow enough to prevent an excessive increase in temperature of the blind fastener when the torque wrenches were used. Test shall be run at the rate of 2 r/min to 4 r/min using a torsion machine. End load applied to the torque wrench shall be no more than necessary to maintain engagement of the wrenching surfaces.
- The recorded locking torque shall be in accordance with the blind fastener product specification. Continue disassembling the blind fastener until the nut is separated from the corebolt.

5.2 Experiment data processing

Record the angle and corresponding torque during the test and record the torque-angle curve, and the locking torque.

5.3 Test reports

The test report shall include the following data:

- a) part number, lot identification and manufacturer of blind fastener;
- b) model, serial number and calibration date of test apparatus;
- c) minimum locking torque at disassembly process;
- d) results.

iTeh STANDARD PREVIEW
(standards.iteh.ai)

[ISO 23887:2021](https://standards.iteh.ai/catalog/standards/sist/fc825ade-c303-44c5-b4a4-7c2ee0bc88bd/iso-23887-2021)

<https://standards.iteh.ai/catalog/standards/sist/fc825ade-c303-44c5-b4a4-7c2ee0bc88bd/iso-23887-2021>

iTeh STANDARD PREVIEW
(standards.iteh.ai)

ISO 23887:2021

<https://standards.iteh.ai/catalog/standards/sist/fc825ade-c303-44c5-b4a4-7c2ee0bc88bd/iso-23887-2021>

iTeh STANDARD PREVIEW
(standards.iteh.ai)

ISO 23887:2021

<https://standards.iteh.ai/catalog/standards/sist/fc825ade-c303-44c5-b4a4-7c2ee0bc88bd/iso-23887-2021>