



~~Designation: E1019-08~~ Designation: E1019 - 11

Standard Test Methods for Determination of Carbon, Sulfur, Nitrogen, and Oxygen in Steel, Iron, Nickel, and Cobalt Alloys by Various Combustion and Fusion Techniques¹

This standard is issued under the fixed designation E1019; the number immediately following the designation indicates the year of original adoption or, in the case of revision, the year of last revision. A number in parentheses indicates the year of last reapproval. A superscript epsilon (ϵ) indicates an editorial change since the last revision or reapproval.

This standard has been approved for use by agencies of the Department of Defense.

1. Scope

1.1 These test methods cover the determination of carbon, sulfur, nitrogen, and oxygen, in ~~steel and in steel~~, iron, nickel, and cobalt alloys having chemical compositions within the following limits:

Element	Concentration Range, %
Aluminum	0.001 to 18.00
Antimony	0.002 to 0.03
Arsenic	0.0005 to 0.10
Beryllium	0.001 to 0.05
Bismuth	0.001 to 0.50
Boron	0.0005 to 1.00
Cadmium	0.001 to 0.005
Calcium	0.001 to 0.05
Carbon	0.001 to 4.50
Cerium	0.005 to 0.05
Chromium	0.005 to 35.00
Cobalt	0.01 to 75.0
Columbium	0.002 to 6.00
Niobium	0.002 to 6.00
Copper	0.005 to 10.00
Hydrogen	0.0001 to 0.0030
Iron	0.01 to 100.0
Lead	0.001 to 0.50
Magnesium	0.001 to 0.05
Manganese	0.01 to 20.0
Molybdenum	0.002 to 30.00
Nickel	0.005 to 84.00
Nitrogen	0.0005 to 0.50
Oxygen	0.0005 to 0.03
Phosphorus	0.001 to 0.90
Selenium	0.001 to 0.50
Silicon	0.001 to 6.00
Sulfur (Metal Reference Materials)	0.002 to 0.35
Sulfur (Potassium Sulfate)	0.001 to 0.600
Tantalum	0.001 to 10.00
Tellurium	0.001 to 0.35
Tin	0.002 to 0.35
Titanium	0.002 to 5.00
Tungsten	0.005 to 21.00
Vanadium	0.005 to 5.50
Zinc	0.005 to 0.20
Zirconium	0.005 to 2.500

1.2 The test methods appear in the following order:

Sections

¹ These test methods are under the jurisdiction of ASTM Committee E01 on Analytical Chemistry for Metals, Ores, and Related Materials and are the direct responsibility of Subcommittee E01.01 on Iron, Steel, and Ferroalloys.

~~Current edition approved Nov. 1, 2008. Published November 2008. Originally approved in 1984. Last previous edition approved in 2003 as E1019-03. DOI: 10.1520/E1019-08.~~

Current edition approved March 15, 2011. Published June 2011. Originally approved in 1984. Last previous edition approved in 2008 as E1019-08. DOI: 10.1520/E1019-11.

Carbon, Total, by the Combustion–Instrumental Measurement Test Method	10-20
Nitrogen by the Inert Gas Fusion–Thermal Conductivity Test Method	32-42
Oxygen by the Inert Gas Fusion Test Method	43-54
Sulfur by the Combustion–Infrared Absorption Test Method (Calibration with Metal Reference Materials)	55-65
Sulfur by the Combustion–Infrared Absorption Test Method (Potassium Sulfate Calibration)	21-31

1.3 The values stated in SI units are to be regarded as standard. No other units of measurement are included in this standard.

1.4 *This standard does not purport to address all of the safety concerns, if any, associated with its use. It is the responsibility of the user of this standard to establish appropriate safety and health practices and determine the applicability of regulatory limitations prior to use.* Specific hazards statements are given in Section 6.

2. Referenced Documents

2.1 ASTM Standards:²

D1193 [Specification for Reagent Water](#)

E29 [Practice for Using Significant Digits in Test Data to Determine Conformance with Specifications](#)

E50 [Practices for Apparatus, Reagents, and Safety Considerations for Chemical Analysis of Metals, Ores, and Related Materials](#)

E135 [Terminology Relating to Analytical Chemistry for Metals, Ores, and Related Materials](#)

E173 [Practice for Conducting Interlaboratory Studies of Methods for Chemical Analysis of Metals³](#)

E1601 [Practice for Conducting an Interlaboratory Study to Evaluate the Performance of an Analytical Method](#)

E1806 [Practice for Sampling Steel and Iron for Determination of Chemical Composition](#)

3. Terminology

3.1 For definition of terms used in this test method, refer to Terminology E135.

4. Significance and Use

4.1 These test methods for the chemical analysis of metals and alloys are primarily intended to test such materials for compliance with compositional specifications. It is assumed that all who use these test methods will be trained analysts, capable of performing common laboratory procedures skillfully and safely. It is expected that work will be performed in a properly equipped laboratory.

5. Apparatus and Reagents

5.1 Apparatus and reagents required for each determination are listed in separate sections preceding the procedure.

6. Hazards

6.1 For hazards to be observed in the use of certain reagents in this test method, refer to Practices E50.

6.2 Use care when handling hot crucibles and operating furnaces to avoid personal injury by either burn or electrical shock.

7. Sampling

7.1 For procedures for sampling the materials, refer to those parts of Practice E1806.

8. Rounding Calculated Values

8.1 Calculated values shall be rounded to the desired number of places as directed in Practice E29.

9. Interlaboratory Studies

9.1 These test methods have been evaluated in accordance with Practice E173. The Reproducibility R_2 of Practice E173 corresponds to the Reproducibility Index R of Practice E1601. The Repeatability R_1 of Practice E173 corresponds to the Repeatability Index r of Practice E1601.

TOTAL CARBON BY THE COMBUSTION INSTRUMENTAL MEASUREMENT TEST METHOD

10. Scope

10.1 This test method covers the determination of carbon in concentrations from 0.005 % to 4.5 %.

² Some of these test methods represent revisions of test methods covered by Test Methods E350, E351, E352, E353, and E354, which appear in the

² For referenced ASTM standards, visit the ASTM website, www.astm.org, or contact ASTM Customer Service at service@astm.org. For Annual Book of ASTM Standards information, refer to the standard's Document Summary page on the ASTM website.

³ Withdrawn. The last approved version of this historical standard is referenced on www.astm.org.

11. Summary of Test Method

11.1 The carbon is converted to carbon dioxide by combustion in a stream of oxygen.

11.1.1 *Thermal Conductivity Test Method*—The carbon dioxide is absorbed on a suitable grade of zeolite, released by heating the zeolite, and swept by helium or oxygen into a chromatographic column. Upon elution, the amount of carbon dioxide is measured in a thermistor-type conductivity cell. Refer to Fig. 1.

11.1.2 *Infrared (IR) Absorption, Test Method A*—The amount of carbon dioxide is measured by infrared (IR) absorption. Carbon dioxide (CO₂) absorbs IR energy at a precise wavelength within the IR spectrum. Energy of this wavelength is absorbed as the gas passes through a cell body in which the IR energy is transmitted. All other IR energy is eliminated from reaching the detector by a precise wavelength filter. Thus, the absorption of IR energy can be attributed to only CO₂ and its concentration is measured as changes in energy at the detector. One cell is used as both a reference and a measure chamber. Total carbon, as CO₂, is monitored and measured over a period of time. Refer to Fig. 2.

11.1.3 *Infrared (IR) Absorption, Test Method B*—The detector consists of an IR energy source, a separate measure chamber and reference chamber, and a diaphragm acting as one plate of a parallel plate capacitor. During specimen combustion, the flow of CO₂ with its oxygen gas carrier is routed through the measure chamber while oxygen alone passes through the reference chamber. Energy from the IR source passes through both chambers, simultaneously arriving at the diaphragm (capacitor plate). Part of the IR energy is absorbed by the CO₂ present in the measure chamber while none is absorbed passing through the reference chamber. This creates an IR energy imbalance reaching the diaphragm, thus distorting it. This distortion alters the fixed capacitance creating an electric signal change that is amplified for measurement as CO₂. Total carbon, as CO₂, is monitored and measured over a period of time. Refer to Fig. 3.

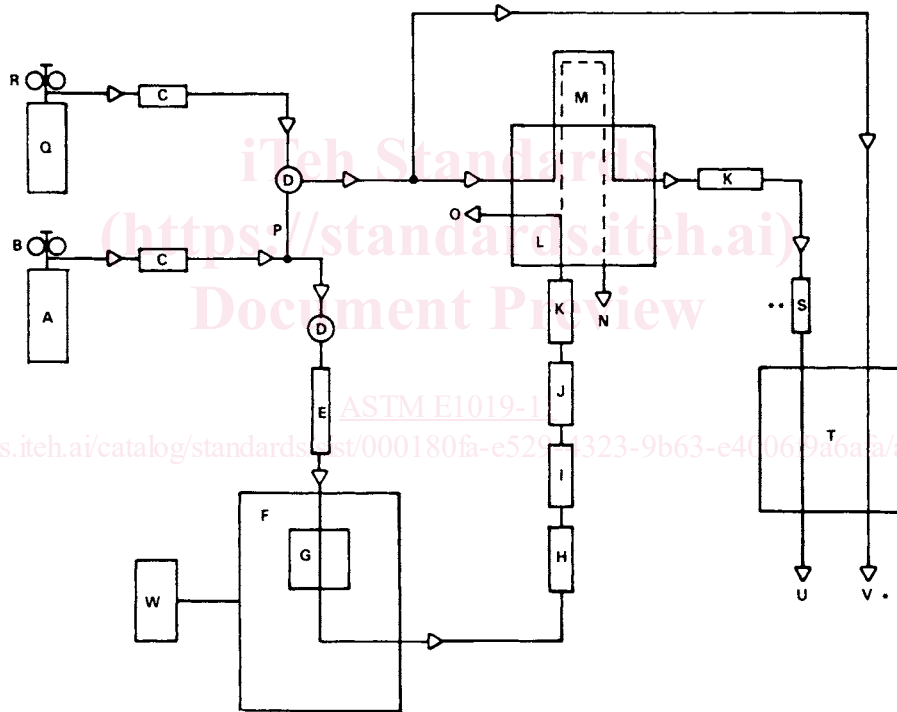

- | | |
|---|---|
| <p>A—High Purity Oxygen
 B—Oxygen Regulator (2 Stage)
 C—Sodium Hydroxide Impregnated Clay/Magnesium Perchlorate
 D—Secondary Pressure Regulator
 E—Flowmeter
 F—Induction Furnace
 G—Combustion Tube
 H—Dust Trap
 I—Manganese Dioxide
 J—Heated CO to CO₂ Converter
 K—Magnesium Perchlorate
 L—Valve Manifold</p> | <p>M—CO₂ Collection Trap
 N—Furnace Combustion Exhaust
 O—Furnace Purge Exhaust
 P—Metal Connector To Use Oxygen As Carrier Gas
 Q—High Purity Helium
 R—Helium Regulator (2 Stage)
 S—Chromagraphic Column
 T—TC Cell/Readout
 U—Measure Flowmeter
 V—Reference Flowmeter
 W—Furnace Power Stat</p> |
|---|---|

* May be sealed chamber if oxygen is carrier gas.

** Not required if oxygen is carrier gas.

FIG. 1 Apparatus for Determination of Carbon by the Combustion Thermal Conductivity Test Method

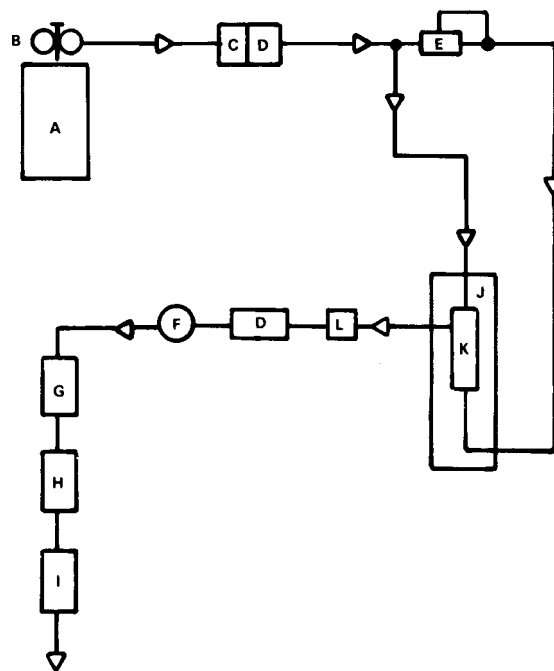

- | | |
|-------------------------------------|-----------------------------------|
| A—Oxygen Cylinder | G—CO-CO ₂ Converter |
| B—Two Stage Regulator | H—SO ₃ Trap |
| C—Sodium Hydroxide Impregnated Clay | I—CO ₂ IR Cell/Readout |
| D—Magnesium Perchlorate | J—Induction Furnace |
| E—Regulator | K—Combustion Area |
| F—Flow Controller | L—Dust Trap |

FIG. 2 Infrared Absorption Test Method A

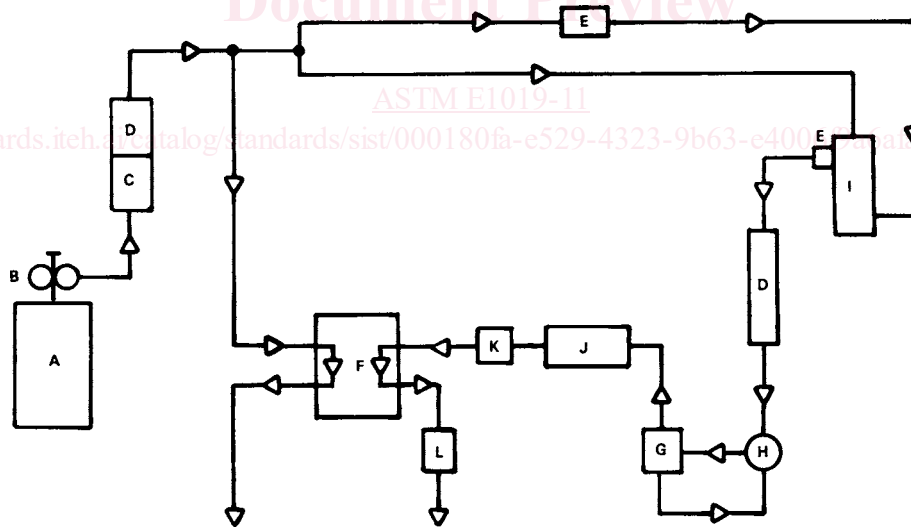

- | | |
|-------------------------------------|-----------------------------------|
| A—Oxygen Cylinder | G—Orifice |
| B—Two Stage Regulator | H—Pressure Regulator |
| C—Sodium Hydroxide Impregnated Clay | I—Combustion Chamber |
| D—Magnesium Perchlorate | J—CO to CO ₂ Converter |
| E—Dust Trap | K—SO ₃ Trap |
| F—IR Cell/Readout | L—Measure Flow Rotameter |

FIG. 3 Infrared Absorption Test Method B

11.1.4 *Infrared (IR) Absorption, Test Method C, Closed Loop*—The combustion is performed in a closed loop, where CO and CO₂ are detected in the same infrared cell. Each gas is measured with a solid state energy detector. Filters are used to pass the appropriate IR wavelength to each detector. In the absence of CO and CO₂, the energy received by each detector is at its maximum. During combustion, the IR absorption properties of CO and CO₂ gases in the chamber cause a loss of energy; therefore a loss in

signal results which is proportional to concentrations of each gas in the closed loop. Total carbon, as CO₂ plus CO, is monitored and measured over a period of time. Refer to Fig. 4.

11.2 This test method is written for use with commercial analyzers, equipped to perform the above operations automatically and calibrated using steels of known carbon content.

12. Interferences

12.1 The elements ordinarily present do not interfere.

12.1 For the scope of elements typically found in materials to be tested by this method refer to 1.1.

13. Apparatus

13.1 *Combustion and Measurement Apparatus*—See Figs. 1-4.

13.2 *Crucibles*—Use crucibles that meet or exceed the specifications of the instrument manufacturer and preheat in a suitable furnace for not less than 40 min at approximately 1000°C. Remove from the furnace and cool before use. Crucibles may be stored in a desiccator prior to use. Preheating of crucibles is particularly important for low levels of carbon. It may not be required for the determination of higher levels of carbon such as those found in pig iron. —Use crucibles that meet or exceed the specifications of the instrument manufacturer and prepare the crucibles by heating in a suitable furnace for not less than 40 min at approximately 1000 °C. Remove from the furnace and cool before use. Crucibles may be stored in a desiccator prior to use. Heating of crucibles is particularly important when analyzing for low levels of carbon and may not be required if the material to be analyzed has higher levels of carbon such as that found in pig iron. Above certain concentrations, as determined by the testing laboratory, the nontreatment of crucibles will have no adverse effect. The analytical ranges for the use of untreated crucibles shall be determined by the testing laboratory and supporting data shall be maintained on file to validate these ranges.

13.3 *Crucible Tongs*—Capable of handling recommended crucibles.

14. Reagents

14.1 *Purity of Reagents*—Reagent grade chemicals shall be used in all tests. Unless otherwise indicated, it is intended that all

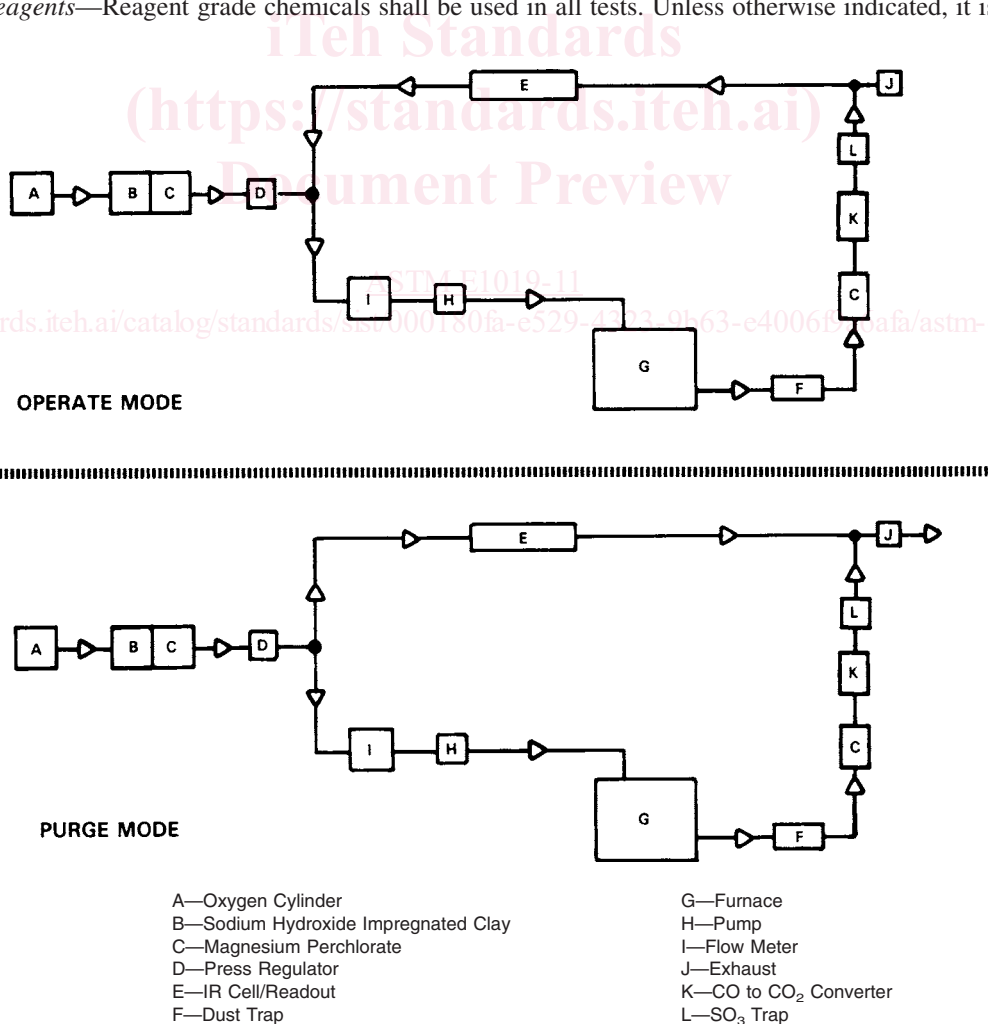

FIG. 4 Infrared Absorption Test Method C—Closed Loop

reagents shall conform to the specifications of the Committee on Analytical Reagents of the American Chemical Society, where such specifications are available.⁴ Other grades may be used, provided it is first ascertained that the reagent is of sufficiently high purity to permit its use without lessening the accuracy of the determination.

14.2 *Acetone*—The residue after evaporation ~~must~~shall be < 0.0005 %.

14.3 *Copper (Low Carbon)*, granular (10 mesh to 30 mesh) (Note 1).

14.4 *Magnesium Perchlorate*, (known commercially as *Anhydron*)— Use the purity specified by the instrument manufacturer.

14.5 *Oxygen, Ultra-High Purity (purity: 99.95% minimum)*—~~Other grades of oxygen may be used if low and consistent blank readings are obtained, or the oxygen may be purified as described in Practices E50.~~ Oxygen—Purity as specified by the instrument manufacturer.

14.6 *Platinum or Platinized Silica*, ~~heated to 350°C for the conversion of carbon monoxide to carbon dioxide.~~, heated to 350 °C for the conversion of carbon monoxide to carbon dioxide. Use the form specified by the instrument manufacturer.

14.7 *Sodium Hydroxide*, on clay (known commercially as *Ascarite II*)— Use the purity specified by the instrument manufacturer.

14.8 *Tungsten (Low Carbon) Accelerator*, 12 mesh to 20 mesh (Note 1).

14.9 *Tungsten-Tin (Low Carbon) Accelerator*, 20 mesh to 40 mesh or 12 mesh to 20 mesh.

NOTE 1—The accelerator should contain no more than 0.001 % carbon. If necessary, wash three times with acetone by decantation to remove organic contaminants and dry at room temperature. The mesh size is critical to the inductive coupling which heats the sample. Some manufacturers of accelerators may not certify the mesh size on a lot to lot basis. These accelerators may be considered acceptable for use without verifying the mesh size.

15. Preparation of Apparatus

15.1 Assemble the apparatus as recommended by the manufacturer.

~~15.2 Test the furnace and analyzer to ensure the absence of leaks and make the required electrical power connections. Prepare the analyzer for operation according to the manufacturer's instructions. Make a minimum of two determinations using the specimen and accelerator as directed in~~

15.2 Test the furnace and analyzer to ensure the absence of leaks and make the required electrical power connections. Prepare the analyzer for operation in a manner consistent with the manufacturer's instructions. Change the chemical reagents and filters at the intervals recommended by the instrument manufacturer. Make a minimum of two determinations using the specimen and accelerator as directed in 18.1.2 and 18.1.3 before attempting to calibrate the system or determine the blank. Avoid the use of reference materials for instrument conditioning.

16. Sample Preparation

~~16.1 The sample should be uniform in size, but not finer than 40 mesh.~~

16.1 The specimens should be uniform in size, but not finer than 40 mesh. Specimens will typically be in the form of chips, drillings, slugs, or solids. Specimens shall be free of any residual lubricants and cutting fluids. It may be necessary to clean specimens to remove residual lubricants and cutting fluids. Any cleaned specimens shall be rinsed in acetone and dried completely before analysis.

16.2 If necessary, wash in acetone or another suitable solvent and dry.

17. Calibration

17.1 *Calibration Reference Materials* (Note 2):

17.1.1 For Range I, 0.005 % to 0.10 % carbon, select three certified reference materials containing approximately 0.005 %, 0.05 %, and 0.10 % carbon and designate them as Calibrants A, B, and C, respectively. Some labs may use accelerator with a certified carbon value as Calibrant A.

17.1.2 For Range II, 0.10 % to 1.25 % carbon, select two certified reference materials containing approximately 0.12 % and 1.00 % carbon and designate them as Calibrants BB and CC, respectively.

17.1.3 For Range III, 1.25 % to 4.50 % carbon, select two certified reference materials containing approximately 1.25 % and 4.00 % carbon and designate them as Calibrants BBB and CCC, respectively.

NOTE 2—The uncertainty of results obtained using this test method is dependent on the uncertainty of the values assigned to the calibration reference materials. The homogeneity of the reference materials ~~must~~shall be considered as well, if it was not included in the derivation of the published uncertainty values.

17.2 *Adjustment of Response of Measurement System:*

~~17.2.1 Transfer 1.0 g of Calibrant B, weighed to the nearest 1 mg, and approximately 1.5 g of accelerator to a preheated crucible. Some manufacturers provide scoops that dispense approximately 1.5 g of accelerator. Once it is verified that the scoop delivers~~

⁴ *Reagent Chemicals, American Chemical Society Specifications*, American Chemical Society, Washington, DC. For suggestions on the testing of reagents not listed by the American Chemical Society, see *Analar Standards for Laboratory Chemicals*, BDH Ltd., Poole, Dorset, U.K. (<http://uk.vwr.com>), and the *United States Pharmacopeia—National Formulary*, U.S. Pharmacopeial Convention, Inc. (USPC), Rockville, MD (<http://www.usp.org/USPNF>).

this approximate weight, it is acceptable to use this device for routine dispensing of accelerator.

17.2.2 Proceed as directed in

17.2.1 Modern instruments may not require adjustment of the measurement system response prior to calibration. For these instruments proceed directly to 17.3 after the conditioning runs described in 15.2.

17.2.2 Transfer 1.0 g of Calibrant B, weighed to the nearest 1 mg, and approximately 1.5 g of accelerator to a crucible. Some manufacturers provide scoops that dispense approximately 1.5 g of accelerator. Once it is verified that the scoop delivers this approximate mass, it is acceptable to use this device for routine dispensing of accelerator.

17.2.3 Proceed as directed in 18.1.2 and 18.1.3.

17.2.3 Repeat 17.2.1 and 17.2.2 until the absence of drift is indicated. Adjust the signal to provide a reading within ± 0.003 of the certified percent carbon value for the certified reference material.

17.2.4 Repeat 17.2.2 and 17.2.3 until the absence of drift is indicated by stable carbon readings being obtained. Consistency is indicated by consecutive runs agreeing within 0.001 % carbon. If using an instrument which requires manual adjustment, adjust the signal to provide a reading within ± 0.003 of the certified percent carbon value for the certified reference material.

17.3 *Determination of Blank Reading—Range I:*

17.3.1 Add approximately 1.5 g of accelerator into a preheated crucible. If required, 1.0 g of Calibrant A, weighed to the nearest 1 mg, may be added to the crucible.

17.3.2 Proceed as directed in 18.1.2 and 18.1.3.

17.3.3 Repeat 17.3.1 and 17.3.2 a sufficient number of times to establish that low (less than 0.002 % of carbon) and consistent/stable (± 0.0002 % of carbon) readings are obtained. Blank values are equal to the total result of the accelerator. If Calibrant A was used, blank values are equal to the total result of the accelerator and Calibrant A minus the certified value of Calibrant A.

17.3.4 Record the average value of at least the last three or more stable blank determinations.

17.3.5 If the blank readings are too high or inconsistent/unstable, determine the cause, correct it, and repeat the steps as directed in 17.3.1-17.3.4.

17.3.6 Enter the average blank value in the analyzer (Note 3); refer to manufacturer's instructions. This mechanism will electronically compensate for the blank value. Refer to the manufacturer's instructions for specific instructions on performing this function. Typically the instrument will electronically compensate for the blank value.

NOTE 3—If the unit does not have this function, the blank value must shall be subtracted from the total result prior to any calculation.

17.4 *Determination of Blank Reading—Range II*—Proceed as directed in 17.3.

17.5 *Determination of Blank Reading—Range III:*

17.5.1 Transfer 0.5 g of Calibrant A, weighed to the nearest 1 mg, and approximately 1.5 g of accelerator to a preheated crucible.

17.5.2 Proceed as directed in 17.3.2-17.3.6.

17.6 *Calibration—Range I (0.005 % to 0.10 % carbon) Carbon):*

17.6.1 Weigh four 1.0 g specimens of Calibrant C, to the nearest 1 mg, then place in preheated crucibles. To each, add approximately 1.5 g of accelerator (see Note 5).

17.6.2 Follow the calibration procedure recommended by the manufacturer. Use Calibrant C as the primary calibrant and analyze at least three specimens to determine the measurement response to be used in the calibration slope regression. Treat each specimen, as directed in 18.1.2 and 18.1.3, before proceeding to the next one.

17.6.3 Confirm the calibration by analyzing Calibrant C following the calibration procedure. The value should be within the uncertainty limits of the certified value for Calibrant C. If not, repeat 17.6.1 and 17.6.2.

17.6.3 Confirm the calibration by analyzing Calibrant C following the calibration procedure. The result should agree with the certified value within a suitable confidence interval (see Note 4). If the result agrees with the certified value within the uncertainty provided on the certificate of analysis, the calibration is acceptable. Also, if the certified value falls within an interval calculated as described in Eq 1, the calibration is acceptable.

$$Test\ Result - t \cdot s \leq Certified\ Value \leq Test\ Result + t \cdot s \quad E1019-11_1 \quad (1)$$

where:

s = standard deviation of the analyses run in 17.6,

n = number of analyses (that is, 3 to 5), and

t = Student's t value, which is for $n = 3$, $t = 4.30$; for $n = 4$, $t = 3.18$; for $n = 5$, $t = 2.78$ at the 95 % confidence level.

NOTE 4—The procedure for verifying calibrants outlined in the original version of this test method required the test result to be compared to “the uncertainty limits of the certified value for the calibrant,” typically interpreted as the range defined by the certified value plus or minus its associated uncertainty. The original version was utilized in the generation of the data in this test method's precision and bias statements. The current method in 17.6.3 for confirming the standardization is statistically rigorous and should be used in general practice. As an option, the laboratory may obtain an estimate of s from a control chart maintained as part of their quality control program. If the control chart contains a large number of measurements ($n > 30$), t may be set equal to 2 at the 95 % confidence level. At its discretion, the laboratory may choose to set a smaller range for the acceptable test result.

17.6.4 Weigh at least two 1.0 g specimens of Calibrant B, weighed to the nearest 1 mg, and transfer them to preheated crucibles. To each, add approximately 1.5 g of accelerator.

17.6.5 Treat each specimen as directed in 18.1.2 and 18.1.3 before proceeding to the next one.

17.6.6 Record the results of 17.6.4 and 17.6.5 and compare them to the certified carbon value of Calibrant B. The results should be within the uncertainty limits of Calibrant B. If not, refer to the manufacturer's instructions for checking the linearity of the system, and compare them to the certified carbon value of Calibrant B. The result should agree with the certified value within a suitable confidence interval (see Note 4). If the result agrees with the certified value within the uncertainty provided on the certificate of analysis, the calibration is acceptable. Also, if the certified value falls within an interval calculated as described in Eq 1, the calibration is acceptable. If not, refer to the manufacturer's instructions for checking the linearity of the system.

~~NOTE 4—The 5—~~The use of 1.5 g of accelerator may not be sufficient for all determinators. The required amount is determined by the analyzer used, induction coil spacing, position of the crucible in the induction coil, age and strength of the oscillator tube, and type of crucible being used. Use the amount required to produce proper sample combustion using the same amount throughout the entire test method.

17.7 Calibration—Range II (0.10 % to 1.25 % carbon):

17.7.1 Proceed as directed in 17.6.1-17.6.3, using Calibrant CC.

17.7.2 Proceed as directed in 17.6.4-17.6.6, using Calibrant BB.

17.8 Calibration—Range III (1.25 % to 4.50 % carbon):

17.8.1 Weigh four 0.5 g specimens of Calibrant CCC, to the nearest 1 mg, and place in ~~preheated~~ crucibles. To each, add approximately 1.5 g of accelerator. ~~17.8.2 Follow~~ Follow the calibration procedure recommended by the manufacturer. Use Calibrant CCC as the primary calibrant and analyze at least three specimens to determine the calibration slope. Treat each specimen, as directed in 18.1.2 and 18.1.3, before proceeding to the next one.

~~17.8.3 Confirm the calibration by analyzing Calibrant CCC following the calibration procedure. The value should be within the uncertainty limits of Calibrant CCC. If not, repeat~~

17.8.2 Confirm the calibration by analyzing Calibrant CCC following the calibration procedure. The result should agree with the certified value within a suitable confidence interval (see Note 4). If the result agrees with the certified value within the uncertainty provided on the certificate of analysis, the calibration is acceptable. Also, if the certified value falls within an interval calculated as described in Eq 1, the calibration is acceptable.

17.8.3 If not, repeat 17.8.1 and 17.8.2.

17.8.4 Weigh at least two 0.5 g specimens of Calibrant BBB, weighed to the nearest 1 mg, and transfer to ~~preheated~~ crucibles. To each, add approximately 1.5 g of accelerator.

17.8.5 Treat each specimen as described in 18.1.2 and 18.1.3 before proceeding to the next one.

17.8.6 Record the results of 17.8.4 and 17.8.5 and compare to the certified carbon value of Calibrant BBB. The results should be within the uncertainty limits of Calibrant BBB. If not, refer to manufacturer's instructions for checking the linearity of the analyzer (Note 5) and compare to the certified carbon value of Calibrant BBB. The result should agree with the certified value within a suitable confidence interval (see Note 4). If the result agrees with the certified value within the uncertainty provided on the certificate of analysis, the calibration is acceptable. Also, if the certified value falls within an interval calculated as described in Eq 1, the calibration is acceptable. If not, refer to manufacturer's instructions for checking the linearity of the analyzer (Note 6).

~~NOTE 5—Verify 6—~~Verify the calibration when: (1) a different lot of crucibles is used, (2) a different lot of accelerator is used, (3) the system has not been in use for 4 h, and (4) the oxygen supply has been changed. Verification should consist of analyzing at least one run of each calibrant. Recalibrate as necessary. ~~the oxygen supply has been changed, and (5) the system has been idle for 1 h. Verification should consist of analyzing at least one specimen of each calibrant. Recalibrate as necessary.~~

18. Procedure

18.1 Procedure—Range I:

18.1.1 Stabilize the furnace and analyzer as directed in Section 15. Transfer approximately 1.0 g of specimen and approximately 1.5 g of accelerator to a ~~preheated~~ crucible. (See 13.2.)

18.1.2 Place the crucible on the furnace pedestal and raise the pedestal into position. Use crucible tongs to handle the ~~preheated~~ crucibles.

18.1.3 Refer to the manufacturer's recommended procedure regarding entry of specimen weight ~~mass~~ and blank value. Start the analysis cycle.

TABLE 1 Statistical Information—Carbon, Range I

Test Specimen	Carbon Found, %	Repeatability (R_1 , Practice E173)	Reproducibility (R_2 , Practice E173)
1. Electrolytic iron (NIST 365, 0.0068 C)	0.007	0.002	0.003
2. Bessemer carbon steel (NIST 8j, 0.081 C)	0.080	0.003	0.006
3. Type 304L stainless steel 18Cr-8Ni (NIST 101f, 0.014 C)	0.014	0.002	0.004
4. Type 446 stainless steel 26Cr (NIST 367, 0.093 C)	0.094	0.003	0.004
5. Nickel steel 36Ni (NIST 126b, 0.090 C)	0.092	0.003	0.004
6. Waspaloy 57Ni-20Cr-14Co-4Mo (NIST 349, 0.080 C)	0.078	0.003	0.004
7. Silicon steel (NIST 131a, 0.004 C)	0.004	0.002	0.002
8. High temperature alloy A286 26Ni-15Cr (NIST 348, 0.044 C)	0.046	0.003	0.004

TABLE 2 Statistical Information—Carbon, Range II

Test Specimen	Carbon Found, %	Repeatability (R_1 , Practice E173)	Reproducibility (R_2 , Practice E173)
1. Basic open hearth steel (NIST 11h, 0.200 C)	0.201	0.006	0.010
2. Basic open hearth carbon steel (NIST 337, 1.07 C)	1.087	0.039	0.053
3. Low alloy electric furnace steel (NIST 51b, 1.21 C)	1.224	0.039	0.048
4. High temperature nickel alloy (LE 105, 0.130 C)	0.130	0.005	0.008
5. Tool steel 8Co-9Mo-2W-4Cr-2V (NIST 153a, 0.902 C)	0.905	0.023	0.027
6. Type 416 stainless steel (NIST 133b, 0.128 C)	0.126	0.005	0.013
7. Low alloy steel 1Cr (NIST 163, 0.933 C)	0.934	0.016	0.020

TABLE 3 Statistical Information—Carbon, Range III

Test Specimen	Carbon Found, %	Repeatability (R_1 , Practice E173)	Reproducibility (R_2 , Practice E173)
1. Tool steel (CISRI 150, 1.56 C)	1.550	0.027	0.049
2. Low alloy electric furnace steel (NIST 51b, 1.21 C)	1.228	0.039	0.050
3. Cast iron (LECO 501-105, 2.20 C)	2.202	0.044	0.056
4. Ductile iron (LECO 501-083, 4.24 C)	4.244	0.083	0.091
5. White iron (LECO 501-024, 3.25 C)	3.274	0.064	0.074
6. Iron (BAM 035-1, 1.31 C)	1.314	0.034	0.048
7. Ferritic stainless steel (BAM 228-1, 2.05 C)	2.040	0.027	0.055

18.2 *Procedure—Range II*—Proceed as directed in 18.1.

18.3 *Procedure—Range III*—Proceed as directed in 18.1, using a 0.5 g specimen.

19. Calculation

19.1 Since most commercially available instruments calculate percent concentrations directly, including corrections for blank and sample weight, calculations by the analyst are not required.

19.1 The calibration function of the equipment shall yield a linear plot described by Eq 2.

$$Y = mX + b \quad \text{E1019-11}_2 \quad (2)$$

where:

Y = measurement response,

M = slope,

X = calibrant concentration, and

b = Y intercept.

Calculation of the calibration function shall be done using a linear least squares regression. Some manufacturers recommend the use of a curve weighting factor where the calibrant concentration is derived as $1/X$. It is acceptable to use this type of curve weighting.

19.2 Since most modern commercially available instruments calculate mass fraction concentrations directly, including corrections for blank and sample mass, manual calculations by the analyst are not required.

NOTE 6—If 7—If the analyzer does not compensate for blank and sample weight/mass values, then use the following formula:

$$\text{Carbon, \%} = [(A - B) \times C/D] \quad \text{E1019-08}_1$$

$$\text{Carbon, \%} = [(A - B) \times C/D] \quad \text{E1019-11}_3 \quad (3)$$

where:

A = DVM reading for specimen, DVM (Digital Volt Meter) reading for specimen,

B = DVM reading for blank,

C = weight/mass compensator setting, and

D = specimen weight, g/specimen mass, g.

20. Precision and Bias ⁵

20.1 *Precision*—Nine laboratories cooperated in testing this test method and obtained the data summarized in Tables 1-3. Testing was performed in compliance with Practice E173 (see 9.1).

20.2 *Bias*—Information on the accuracy of this test method is incomplete at this time. The user is cautioned to verify by the use of certified reference materials, if available, that the accuracy of this test method is adequate for the contemplated use. —No

⁵ Reagent Chemicals, American Chemical Society Specifications, American Chemical Society, Washington, DC, www.chemistry.org. For suggestions on the testing of reagents not listed by the American Chemical Society, see the *United States Pharmacopeia and National Formulary*, U.S. Pharmacopeial Convention, Inc. (USPC), Rockville, MD, http://www.usp.org.

⁶ Supporting data are available from ASTM International Headquarters. Request RR:E01-1093.

information on the bias of this method is known because at the time of the interlaboratory study, suitable reference materials were not available. The user of this method is encouraged to employ accepted reference materials, if available, to determine the presence or absence of bias.

SULFUR BY THE COMBUSTION-IR INFRARED ABSORPTION TEST METHOD (POTASSIUM SULFATE CALIBRATION)

21. Scope

21.1 This test method covers the determination of sulfur in the range of 0.001 % to 0.01 %. As written, this test method is not applicable to cast iron samples.

22. Summary of Test Method

22.1 The sample is combusted in a stream of oxygen that converts the sulfur in the sample to sulfur dioxide. The sulfur is then determined by measured using infrared absorption spectrometry

22.1.1 *Infrared Absorption Test Method A*—Sulfur dioxide (SO₂) absorbs IR energy at a precise wavelength within the IR spectrum. Energy of this wavelength is absorbed as the gas passes through a cell body in which the IR energy is transmitted. All other IR energy is eliminated from reaching the detector by a precise wavelength filter. Therefore, the absorption of IR energy can be attributed to only SO₂ and its concentration is measured as changes in energy at the detector. One cell is used as both a reference and a measure chamber. Total sulfur, as SO₂, is monitored and measured over a period of time. Refer to Fig. 5.

22.1.2 *Infrared Absorption Test Method B*—The combustion is performed in a closed loop where SO₂ is detected in an infrared cell. The SO₂ is measured with a solid state energy detector, and filters are used to pass the appropriate IR wavelength to the detector. During combustion, the IR absorption properties of the SO₂ gas in the chamber causes a loss of energy, therefore a loss in signal results which is proportional to the concentration of the gas in the closed loop. Total sulfur, as SO₂, is monitored and measured over a period of time. Refer to Fig. 6.

22.1.3 *Infrared Absorption Test Method C*—The detector consists of an IR energy source, a separate measure chamber and reference chamber, and a diaphragm acting as one plate of a parallel plate capacitor. During specimen combustion, the flow of SO₂ with its oxygen gas carrier is routed through the measure chamber while oxygen alone passes through the reference chamber. Energy from the IR source passes through both chambers, simultaneously arriving at the diaphragm (capacitor plate). Part of the IR energy is absorbed by the SO₂ present in the measure chamber while none is absorbed passing through the reference chamber. This creates an IR energy imbalance reaching the diaphragm, thus distorting it. This distortion alters the fixed capacitance creating an electric signal change that is amplified for measurement as SO₂. Total SO₂ is monitored and measured over a period of time. Refer to Fig. 7.

23. Interferences

23.1 The elements ordinarily present do not interfere.

23.1 The elements ordinarily present do not interfere. For the scope of elements typically found in materials to be tested by this method refer to 1.1.

24. Apparatus

24.1 *Combustion and Measurement Apparatus*—See Figs. 5-7.

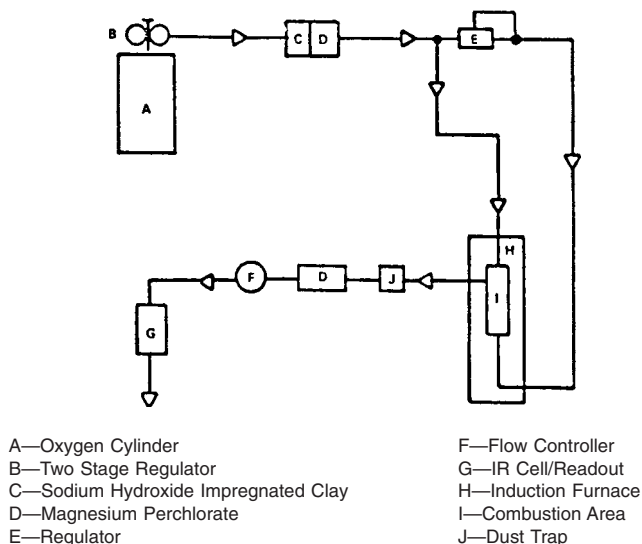

FIG. 5 Infrared Absorption Test Method A

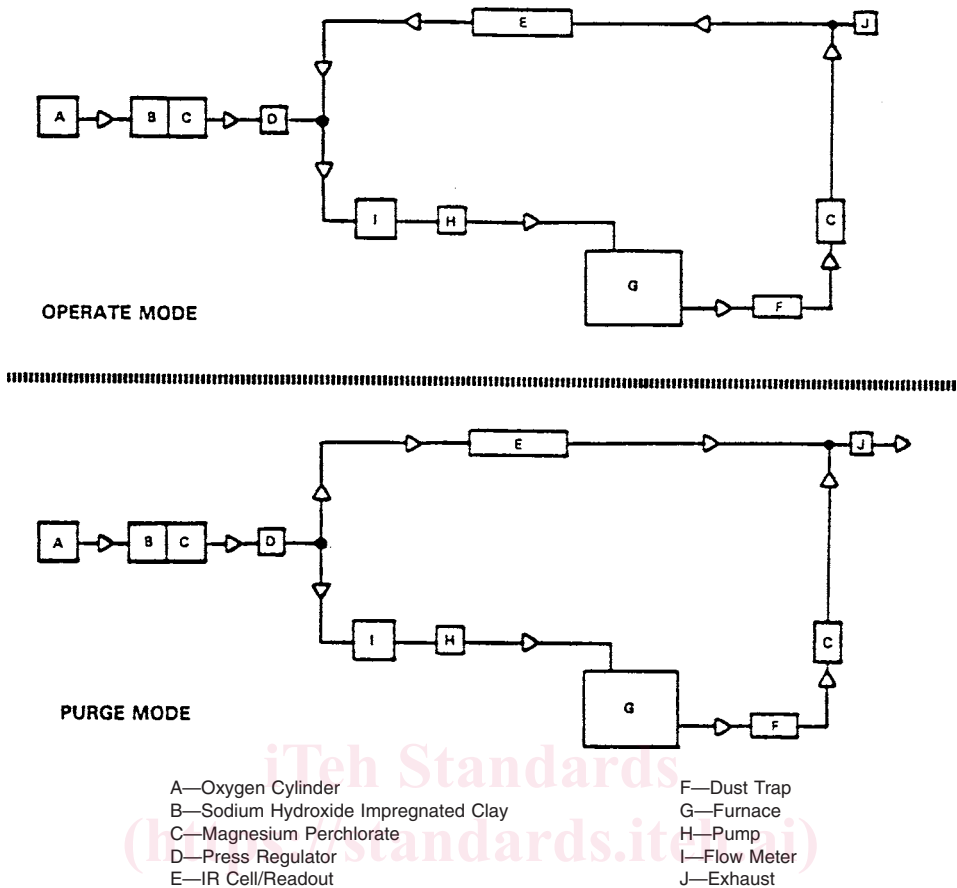

FIG. 6 Infrared Absorption Test Method B

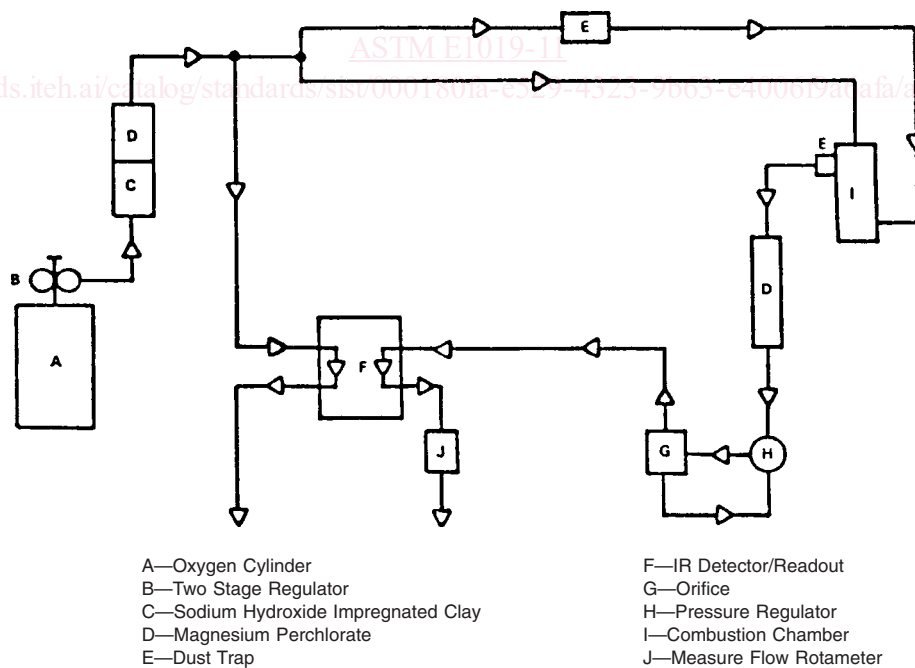

FIG. 7 Infrared Absorption Test Method C

24.2 *Crucibles*—Use crucibles recommended by the manufacturer of the instrument, or equivalent, and preheat in a suitable furnace for not less than 1 h at approximately 1000°C. Remove from furnace and cool before use. Preheated crucibles may be stored in a desiccator prior to use.—Use crucibles that meet or exceed the specifications of the instrument manufacturer and