

---

---

**Plain bearings — Bearing fatigue —  
Part 3:  
Test on plain strips of a metallic  
multilayer bearing material**

*Paliers lisses — Fatigue des paliers —*

*Partie 3: Essai sur éprouvettes plates en matériau antifriction  
métallique multicouche*

**iTeh STANDARD PREVIEW  
(standards.iteh.ai)**

ISO 7905-3:2019

<https://standards.iteh.ai/catalog/standards/sist/5e23fcd0-3b62-41b3-9ab9-3dd9cc555efe/iso-7905-3-2019>



**iTeh STANDARD PREVIEW**  
**(standards.iteh.ai)**

ISO 7905-3:2019

<https://standards.iteh.ai/catalog/standards/sist/5e23fcd0-3b62-41b3-9ab9-3dd9cc555efe/iso-7905-3-2019>



**COPYRIGHT PROTECTED DOCUMENT**

© ISO 2019

All rights reserved. Unless otherwise specified, or required in the context of its implementation, no part of this publication may be reproduced or utilized otherwise in any form or by any means, electronic or mechanical, including photocopying, or posting on the internet or an intranet, without prior written permission. Permission can be requested from either ISO at the address below or ISO's member body in the country of the requester.

ISO copyright office  
CP 401 • Ch. de Blandonnet 8  
CH-1214 Vernier, Geneva  
Phone: +41 22 749 01 11  
Fax: +41 22 749 09 47  
Email: [copyright@iso.org](mailto:copyright@iso.org)  
Website: [www.iso.org](http://www.iso.org)

Published in Switzerland

# Contents

	Page
Foreword .....	iv
<b>1 Scope .....</b>	<b>1</b>
<b>2 Normative references .....</b>	<b>1</b>
<b>3 Terms and definitions .....</b>	<b>1</b>
<b>4 Test specimens .....</b>	<b>1</b>
<b>5 Test method .....</b>	<b>2</b>
<b>6 Evaluation and presentation of test results .....</b>	<b>3</b>
<b>Bibliography .....</b>	<b>5</b>

## iTeh STANDARD PREVIEW (standards.iteh.ai)

[ISO 7905-3:2019](https://standards.iteh.ai/catalog/standards/sist/5e23fcd0-3b62-41b3-9ab9-3dd9cc555efe/iso-7905-3-2019)

<https://standards.iteh.ai/catalog/standards/sist/5e23fcd0-3b62-41b3-9ab9-3dd9cc555efe/iso-7905-3-2019>

## Foreword

ISO (the International Organization for Standardization) is a worldwide federation of national standards bodies (ISO member bodies). The work of preparing International Standards is normally carried out through ISO technical committees. Each member body interested in a subject for which a technical committee has been established has the right to be represented on that committee. International organizations, governmental and non-governmental, in liaison with ISO, also take part in the work. ISO collaborates closely with the International Electrotechnical Commission (IEC) on all matters of electrotechnical standardization.

The procedures used to develop this document and those intended for its further maintenance are described in the ISO/IEC Directives, Part 1. In particular, the different approval criteria needed for the different types of ISO documents should be noted. This document was drafted in accordance with the editorial rules of the ISO/IEC Directives, Part 2 (see [www.iso.org/directives](http://www.iso.org/directives)).

Attention is drawn to the possibility that some of the elements of this document may be the subject of patent rights. ISO shall not be held responsible for identifying any or all such patent rights. Details of any patent rights identified during the development of the document will be in the Introduction and/or on the ISO list of patent declarations received (see [www.iso.org/patents](http://www.iso.org/patents)).

Any trade name used in this document is information given for the convenience of users and does not constitute an endorsement.

For an explanation of the voluntary nature of standards, the meaning of ISO specific terms and expressions related to conformity assessment, as well as information about ISO's adherence to the World Trade Organization (WTO) principles in the Technical Barriers to Trade (TBT) see [www.iso.org/iso/foreword.html](http://www.iso.org/iso/foreword.html).

This document was prepared by Technical Committee ISO/TC 123, *Plain bearing*, Subcommittee SC 2, *Material and lubricants, their properties, characteristics, test methods and testing conditions*.

This second edition cancels and replaces the first edition (ISO 7905-3:1995), of which it constitutes a minor revision. The changes compared to the previous edition are as follows:

- Adjustment to ISO/IEC Directives, Part 2:2018;
- Update of Bibliography.

A list of all parts in the ISO 7905 series can be found on the ISO website.

Any feedback or questions on this document should be directed to the user's national standards body. A complete listing of these bodies can be found at [www.iso.org/members.html](http://www.iso.org/members.html).

# Plain bearings — Bearing fatigue —

## Part 3:

# Test on plain strips of a metallic multilayer bearing material

## 1 Scope

This document specifies a method for the determination of the endurance limit in fatigue of plain strips of multilayer bearing materials. Additionally, it provides the opportunity of studying the influence on the strips of hydraulic pressure and variable temperature.

## 2 Normative references

There are no normative references in this document.

## 3 Terms and definitions

No terms and definitions are listed in this document.

ISO and IEC maintain terminological databases for use in standardization at the following addresses:

- ISO Online browsing platform: available at <https://www.iso.org/obp>
- IEC Electropedia: available at <http://www.electropedia.org/>

## 4 Test specimens

The test specimens shall be flat thin strips of rectangular cross-section to the dimensions shown in [Figure 1](#). To avoid fracture starting at the clamped portion, the edges shall be carefully chamfered by grinding and the test section shall be contoured as shown in [Figure 1](#).

For a multilayer bearing material, the layer dimensions of the test specimen shall be representative of the manufacturing sequence and the test specimen shall be finished to the same surface texture. Care should be taken before and during the test not to damage the surface mechanically or by corrosion. The deficiency of this test method lies in the absence of possible residual stress associated with the bearing manufacturing process.

Dimensions in millimetres

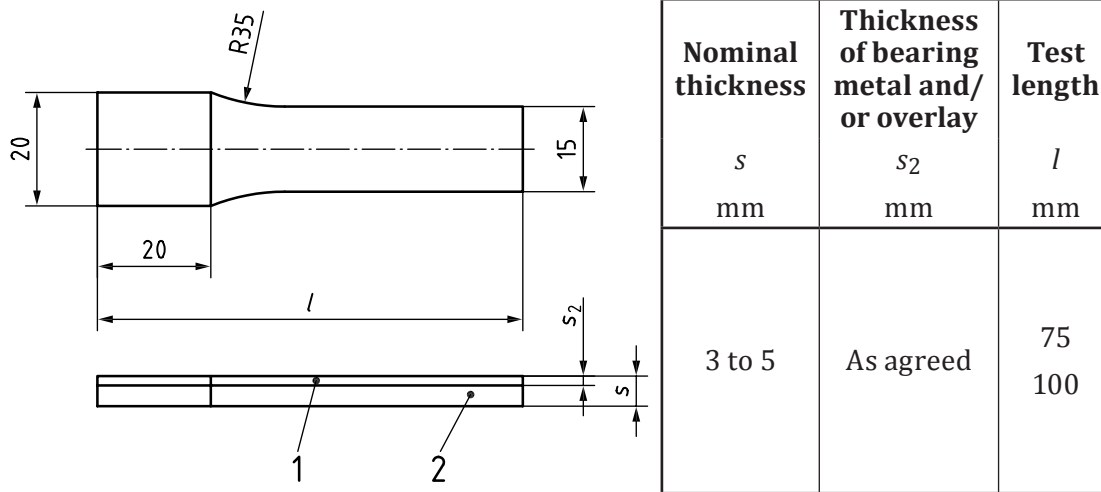

**Key**

- 1 bearing metal
- 2 steel

**Figure 1 — Specimen dimensions and configuration**

**iTeh STANDARD PREVIEW**  
(standards.iteh.ai)

**5 Test method**

The test principle is illustrated in [Figure 2](#). The specimens shall be clamped at one end and loaded at the other end by force or displacement. The load shall fluctuate from tension to compression over the running surface. Additionally, a tensile or compressive prestress may be applied in order to evaluate dependency upon mean stress. The test equipment is preferably located in a chamber containing a lubricant at fixed levels of temperature  $\pm 2$  °C. Alternatively, tests may be conducted in air at fixed levels of temperature  $\pm 2$  °C.

Bending stress shall be measured by a strain gauge near the clamping point on the back of the specimen. The required bending stress at the damaged section may be evaluated by calculation, knowing the relative location of the strain gauge and first crack, and the thickness and Young's modulus of the lining and steel backing.

The stresses in plain layered strips under condition of bending may be evaluated theoretically.

The test frequency shall have a range of 50 Hz to 80 Hz. Crack detection shall be performed by dye penetrant method or by microscope. The amplitude shall be controlled by force ( $F$ ) or displacement ( $d$ ).

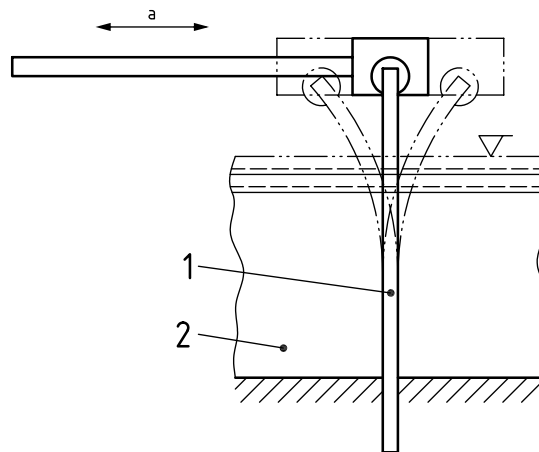
**Key**

- 1 specimen
- 2 medium

a  $F = \bar{F} + F_A \times \sin(\omega \times t)$  or  $s = \bar{s} + s_A \times \sin(\omega \times t)$

**Figure 2 — Test principle****6 Evaluation and presentation of test results**

The measurement instrumentation for the proposed test principle is illustrated in [Figure 3](#). The endurance limit stresses should be presented in the form of  $\sigma_{el}-N$  curves at predetermined temperature ( $\pm 2^\circ\text{C}$ ) against a detailed description of the bearing material. Normally,  $\sigma_{el}-N$  curve testing is terminated for practical considerations at  $50 \times 10^6$  stress cycles. The endurance limit stress may be quoted at a specified number of cycles, e.g.  $3 \times 10^6$ ,  $10 \times 10^6$ ,  $25 \times 10^6$  or  $50 \times 10^6$ . A specimen without failure during fatigue testing to a specified endurance should be identified in the report. Due to the scatter of test results normally experienced and the statistical nature of the fatigue limit, it is recommended that the results be evaluated on the basis of a statistical method.

The endurance limit stress may be presented by means of the Haigh diagram which plots stress amplitude against mean stress. Metallographic examination provides detailed evidence of the damage mechanism, corrosive attack and diffusion resulting from thermal effects.

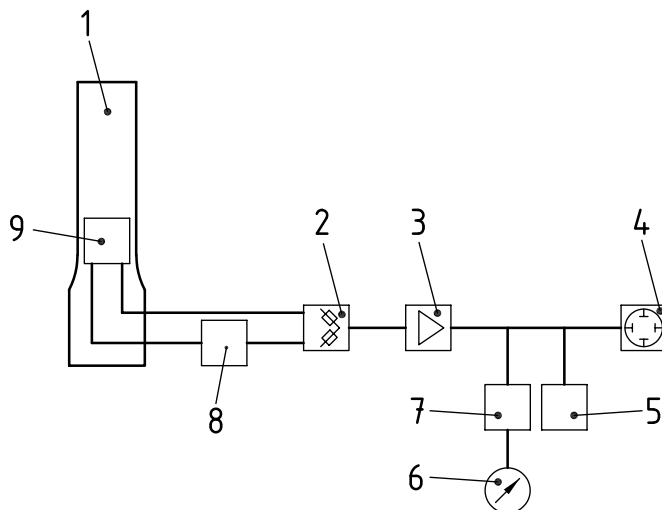

**Key**

- 1 test piece
- 2 completion bridge
- 3 amplifier
- 4 oscilloscope
- 5 event counter
- 6 indicator
- 7 peak detector
- 8 compensating strain gauge
- 9 active strain gauge

**iTeh STANDARD PREVIEW**  
**(standards.iteh.ai)**

<https://standards.iteh.ai/catalog/standards/sist/5e23fcd0-3b62-41b3-9ab9-3dd9cc555e1c/iso-7905-3-2019>

**Figure 3 — Event counter recorder**



## Bibliography

- [1] ISO 3548-1, *Plain bearings — Thin-walled half bearings with or without flange — Part 1: Tolerances, design features and methods of test*
- [2] ISO 4378-1, *Plain bearings — Terms, definitions, classification and symbols — Part 1: Design, bearing materials and their properties*

**iTeh STANDARD PREVIEW**  
**(standards.iteh.ai)**

[ISO 7905-3:2019](https://standards.iteh.ai/catalog/standards/sist/5e23fcd0-3b62-41b3-9ab9-3dd9cc555efe/iso-7905-3-2019)

<https://standards.iteh.ai/catalog/standards/sist/5e23fcd0-3b62-41b3-9ab9-3dd9cc555efe/iso-7905-3-2019>