



**SLOVENSKI STANDARD**  
**SIST ISO 2759:1995**  
**01-junij-1995**

---

Učvrščenost pri raztrganosti papirne plošče

Board -- Determination of bursting strength

Carton -- Détermination de la résistance à l'éclatement

**Ta slovenski standard je istoveten z: ISO 2759:1983**

[SIST ISO 2759:1995](https://standards.iteh.ai/catalog/standards/sist/6884ba70-8449-412b-87e0-d9c98f49ab1f/sist-iso-2759-1995)

<https://standards.iteh.ai/catalog/standards/sist/6884ba70-8449-412b-87e0-d9c98f49ab1f/sist-iso-2759-1995>

**ICS:**

85.060      Papir, karton in lepenka      Paper and board

**SIST ISO 2759:1995**      **en**

**iTeh STANDARD PREVIEW**  
**(standards.iteh.ai)**

SIST ISO 2759:1995

<https://standards.iteh.ai/catalog/standards/sist/6884ba70-8449-412b-87e0-d9c98f49ab1f/sist-iso-2759-1995>

# International Standard



# 2759

INTERNATIONAL ORGANIZATION FOR STANDARDIZATION • МЕЖДУНАРОДНАЯ ОРГАНИЗАЦИЯ ПО СТАНДАРТИЗАЦИИ • ORGANISATION INTERNATIONALE DE NORMALISATION

## Board — Determination of bursting strength

*Carton — Détermination de la résistance à l'éclatement*

Second edition — 1983-11-01

**iTeh STANDARD PREVIEW**  
**(standards.iteh.ai)**

[SIST ISO 2759:1995](#)

<https://standards.iteh.ai/catalog/standards/sist/6884ba70-8449-412b-87e0-d9c98f49ab1f/sist-iso-2759-1995>

UDC 676.017.42 : 539.42

Ref. No. ISO 2759-1983 (E)

**Descriptors** : papers, paperboards, tests, mechanical tests, determination, bursting strength, burst tests.

Price based on 9 pages

## Foreword

ISO (the International Organization for Standardization) is a worldwide federation of national standards bodies (ISO member bodies). The work of developing International Standards is carried out through ISO technical committees. Every member body interested in a subject for which a technical committee has been authorized has the right to be represented on that committee. International organizations, governmental and non-governmental, in liaison with ISO, also take part in the work.

Draft International Standards adopted by the technical committees are circulated to the member bodies for approval before their acceptance as International Standards by the ISO Council.

International Standard ISO 2759 was developed by Technical Committee ISO/TC 6, *Paper, board and pulps*.

This second edition was submitted directly to the ISO Council, in accordance with clause 6.11.2 of part 1 of the Directives for the technical work of ISO. It cancels and replaces the first edition (i.e. ISO 2759-1974), which had been approved by the member bodies of the following countries:

Australia	India	South Africa, Rep. of
Austria	Iran	Spain
Belgium	Ireland	Sweden
Czechoslovakia	Israel	Switzerland
Egypt, Arab Rep. of	Netherlands	Thailand
Finland	New Zealand	Turkey
France	Norway	United Kingdom
Germany, F.R.	Poland	USA
Hungary	Romania	

No member body had expressed disapproval of the document.

# Board — Determination of bursting strength

## 0 Introduction

This International Standard is applicable to boards with bursting strengths between 350 kPa (250 kPa for the components of boards with a combined bursting strength of above 350 kPa) and 5 500 kPa.

An alternative method for materials with bursting strengths of less than 1 100 kPa is specified in ISO 2758.

The scales of many instruments in use for determining this property are at present graduated in kilograms-force per square centimetre, or pounds-force per square inch. For the purpose of this International Standard, the following conversion factors are to be used:

$$1 \text{ kgf/cm}^2 = 98,1 \text{ kPa}$$

$$1 \text{ lbf/in}^2 = 6,89 \text{ kPa}$$

## 1 Scope

This International Standard specifies a method for measuring the bursting strength of board submitted to increasing hydraulic pressure.

## 2 Field of application

This International Standard is applicable in principle to all types of board (including solid and corrugated fibreboard) having bursting strengths within the range 350 to 5 500 kPa.

It is also applicable to papers or boards having bursting strengths as low as 250 kPa if the paper or board is to be used to prepare a material of higher bursting strength, such as corrugated board. In such cases, the measurements will not necessarily have the precision or accuracy stated for this method and it is necessary to include a note in the test report that the test gave results that were below the minimum value required by the method.

## 3 References

- ISO 186, *Paper and board — Sampling for testing.*  
 ISO 187, *Paper and board — Conditioning of samples.*  
 ISO 536, *Paper and board — Determination of grammage.*  
 ISO 2758, *Paper — Determination of bursting strength.*

## 4 Definitions

For the purpose of this International Standard, the following definitions apply.

**4.1 bursting strength:** The maximum uniformly distributed pressure, applied at right angles to its surface, that a single test piece of board can withstand under the test conditions.

**4.2 burst index:** The bursting strength of the board divided by the grammage of the conditioned board determined by the standard method of the test.

## 5 Principle

A test piece, placed over a circular elastic diaphragm, is rigidly clamped at the periphery but free to bulge with the diaphragm. Hydraulic fluid is pumped at a constant rate, bulging the diaphragm until the test piece ruptures. The bursting strength of the test piece is the maximum value of the applied hydraulic pressure.

## 6 Apparatus

The apparatus shall be installed on a reasonably horizontal surface and shall be free from externally induced vibrations.

All air shall be removed from the hydraulic system by bleeding. The apparatus shall be checked for expansion and for leaks using the methods described in annex E.

**6.1 Clamping system,** for clamping the test piece firmly and uniformly between two annular plane, parallel surfaces, which shall be smooth (but not polished) and grooved as described in annex A, which also gives the dimensions of the clamping system.

The upper clamping plate shall be held in a swivel joint or similar device so as to ensure that the clamping pressure is distributed evenly.

During tests, the apertures in the two clamping plates shall be concentric to within 0,25 mm and the clamping surfaces shall be flat and parallel. The method of checking the clamps is given in annex B.

The clamping pressure shall be sufficient to prevent slippage during the test but not so great as to damage the test piece in such a way that rupture could occur around the periphery of the test area. In general, the clamping pressure shall not be less

## ISO 2759-1983 (E)

than 690 kPa (see annex C). In the case of corrugated boards, a clamping pressure of 690 kPa is sufficient to collapse the flutes of most boards but generally prevents slippage. The clamping pressure used shall be stated in the test report which, for corrugated boards, should also state whether the flutes collapsed under the pressure used.

Maximum and minimum clamping pressures may be agreed between the parties concerned.

**6.2 Diaphragm**, circular, of elastic material, clamped securely with its upper surface about 5,5 mm below the top plane of the lower clamping plate. The material and construction of the diaphragm shall be such as to require the following pressures to bulge the diaphragm above the top face of the lower clamp:

- bulge height: 10 mm, pressure range: 170 to 220 kPa;
- bulge height: 18 mm, pressure range: 250 to 350 kPa.

A new diaphragm will frequently require a higher pressure for a given bulge height than one that has been used. Diaphragms shall be checked at frequent intervals and changed if the bulge height requirements are not met. Care shall be taken during the fitting of the diaphragm to eliminate all air trapped under the diaphragm.

**6.3 Hydraulic system**, to apply a controlled hydraulic pressure to the underside of the diaphragm until the test piece bursts. The pressure shall be generated by a piston forcing a suitable liquid (chemically pure glycerol, ethylene glycol containing a corrosion inhibitor, or a low viscosity silicone oil) against the lower surface of the diaphragm. The hydraulic system and liquid used shall be free from air bubbles. The pumping rate shall be  $170 \pm 15$  ml/min (see annex E).

The piston shall be motor operated.

## 6.4 Pressure gauges.

**6.4.1 Bourdon gauge**, maximum reading type, of appropriate capacity.

This instrument should preferably be used within the range 25 to 75 % and, in no case, outside the range 15 to 85 % of the capacity of the scale.<sup>1)</sup> The scale shall have a minimum diameter of 95 mm and graduations extending over a minimum arc of  $270^\circ$ . At any point within the working range it shall be accurate to within 0,5 % of the maximum capacity of the scale. The scale shall be subdivided into at least 70 divisions.

The expansibility of the gauge shall be constant to within 20 % over its full working range and shall be such that the volume of hydraulic fluid required to give a full scale reading does not exceed 0,4 ml (see annex E). The gauge shall be fitted with a scale adjustment device for fine setting.

The maximum reading pointer shall not introduce errors into the scale readings during use. This can only be confirmed by dynamic calibration of the gauge. Gauges with pointers having a frictional couple of about  $0,3 \text{ mN} \cdot \text{m}$  and a moment of inertia of between 1 and  $10 \text{ g} \cdot \text{cm}^2$  have been found to be satisfactory (see annex D).

The gauge shall be provided with a bleed hole or other device to facilitate the complete filling of the gauge with the hydraulic fluid.

The total measuring range of the instrument may be divided by the use of two gauges, independent of each other in use; by checking the expansibility of the system with the selector valve in each appropriate position, the suitability of the selector valve can be confirmed (see annex E).

### 6.4.2 Transducer type gauge.

An example of suitable equipment is a pressure transducer which operates with negligible inertia and expansion and a pressure recorder accurate to within 0,2 %. If a digital read-out device is fitted, the reading shall not change by more than 1 unit after the test piece has ruptured.

## 7 Calibration

Each gauge shall be calibrated before initial use and afterwards at sufficiently frequent intervals to maintain the specified accuracy. A deadweight tester may be used (see annex D). Calibration shall be carried out with the gauge mounted in the same position as it occupies on the instrument and preferably when mounted on the instrument. If the gauge is accidentally used beyond its capacity it shall be recalibrated before being used again.

## 8 Sampling and preparation of test pieces

The board to be tested shall be sampled in accordance with ISO 186. Test pieces shall be larger in area than the clamps of the burst tester and no area covered by the clamp in one test shall be included in subsequent test areas.

Test pieces shall not include areas containing watermarks, creases, or visible damage.

Test pieces shall be conditioned in accordance with ISO 187.

<sup>1)</sup> If the capacity of the gauge is known to exceed the graduated scale reading by 20 %, the upper limit of scale reading may be increased to 90 % and 100 %, respectively.

The number of test pieces required depends on whether or not separate results are required for burst tests carried out with each surface in contact with the diaphragm.

NOTE — When laboratory sheets are being tested and when only narrow samples are available for testing, it may not be possible to avoid the clamped area overlapping the edges of the test piece or an adjacent clamped area. In such instances, the overlap should be carefully minimized and the test piece inspected after use to ensure that the overlap has not caused the clamped board to slip. If clamping is not in accordance with the stated procedure, this fact should be stated in the test report.

## 9 Procedure

Tests shall be carried out in the standard atmosphere, defined in ISO 187, used for the conditioning of test pieces in accordance with clause 8.

Where alternative gauges are available, select the most suitable gauge, if necessary by carrying out a preliminary test using the gauge with the greatest range, and isolate the other gauges.

Raise the clamp and insert the test piece in a position enabling the full clamping area to be used (see the note to clause 8); then firmly apply the clamp to the test piece at the clamping force specified in 6.1.

Apply hydraulic pressure at the correct rate until the test piece bursts. Retract the piston until the diaphragm is below the level of the lower clamping plate. Read the pressure indicated on the gauge to three significant figures. Then release the clamp and return the maximum reading pointer to its starting position for the next test. Readings shall be rejected when visible slippage of the test piece (as shown by movement of the test piece area outside the clamps or by creasing of the test piece in the clamped area) has occurred. In cases of doubt, the use of a larger test piece will frequently establish whether slippage is occurring. Readings shall also be rejected if the type of failure (for example severance at the periphery of the test zone) indicates that the test piece was damaged by excessive clamping pressure or by rotation of the clamps during clamping.

NOTE — Care should be taken when returning the pointer to the starting position. On some instruments, if it is returned too rapidly, the pointer may be damaged.

If separate results are required for each surface of the board in contact with the diaphragm, twenty tests shall be carried out to obtain each result. If separate results are not required for the two surfaces of the board, ten tests shall be carried out with one side uppermost and ten tests with the other side uppermost.

NOTE — The surface in contact with the diaphragm is considered to be the surface under test.

## 10 Expression of results

The mean bursting strength,  $P$ , expressed in kilopascals, is given by the mean value of the maximum hydraulic pressure,  $\beta$  in kilopascals.

The burst index,  $X$ , expressed in kilopascal square metres per gram, may be calculated from the bursting strength by the formula

$$X = \frac{P}{W}$$

where

$P$  is the mean bursting strength, in kilopascals;

$W$  is the grammage of the specimen, in grams per square metre, determined in accordance with ISO 536.

## 11 Precision

The precision depends to a great extent on the variability of the material tested, and the accuracy of the mean on a large number of factors, the most important possibly being the efficiency of clamping.

It is difficult, under practical circumstances, to separate these factors, but some typical results will illustrate the variations likely to be encountered.

Within laboratory (12 materials):

Coefficient of variation of individual results: 3,8 to 8,5 %;

95 % confidence limits of mean result:  $\pm 1,8$  to 4,0 %.

Between laboratories (randomized test pieces):

Coefficient of variation of mean results: 5,8 to 9,6 %.

Thus it can be seen that, generally, differences in the mean results for two boards of less than about 5 % on a single instrument or about 10 % on instruments in different laboratories cannot be taken as proof of a real difference in bursting strength.

## 12 Sources of error

The main sources of error are as follows:

- faulty calibration of the pressure gauge (see annex D);
- incorrect rate of increase in pressure (increased rates lead to an apparent increase in bursting strength) (see annex E);
- defective diaphragm (see 6.2);
- inadequate or uneven clamping (which generally leads to an apparent increase in bursting strength) (see annexes B and C);
- presence of air in the system (which generally leads to an apparent decrease in bursting strength) (see annex E).

**ISO 2759-1983 (E)****13 Test report**

The test report shall include the following particulars:

- a) a reference to this International Standard;
- b) the date and place of testing, the make of instrument and the model number;
- c) the standard conditioning atmosphere used;
- d) the mean value of the bursting strength to three significant figures (if required, for each surface of the board);
- e) if required, the burst index to three significant figures;
- f) the 95 % confidence limits of the mean bursting strength;
- g) the clamping pressure used;
- h) in the case of corrugated boards, whether the flutes collapsed;
- j) any deviations from the method specified.

**iTeh STANDARD PREVIEW**  
**(standards.iteh.ai)**

SIST ISO 2759:1995

<https://standards.iteh.ai/catalog/standards/sist/6884ba70-8449-412b-87e0-d9c98f49ab1f/sist-iso-2759-1995>



## Annex A

## Dimensions of the clamping system

Dimensions in millimetres

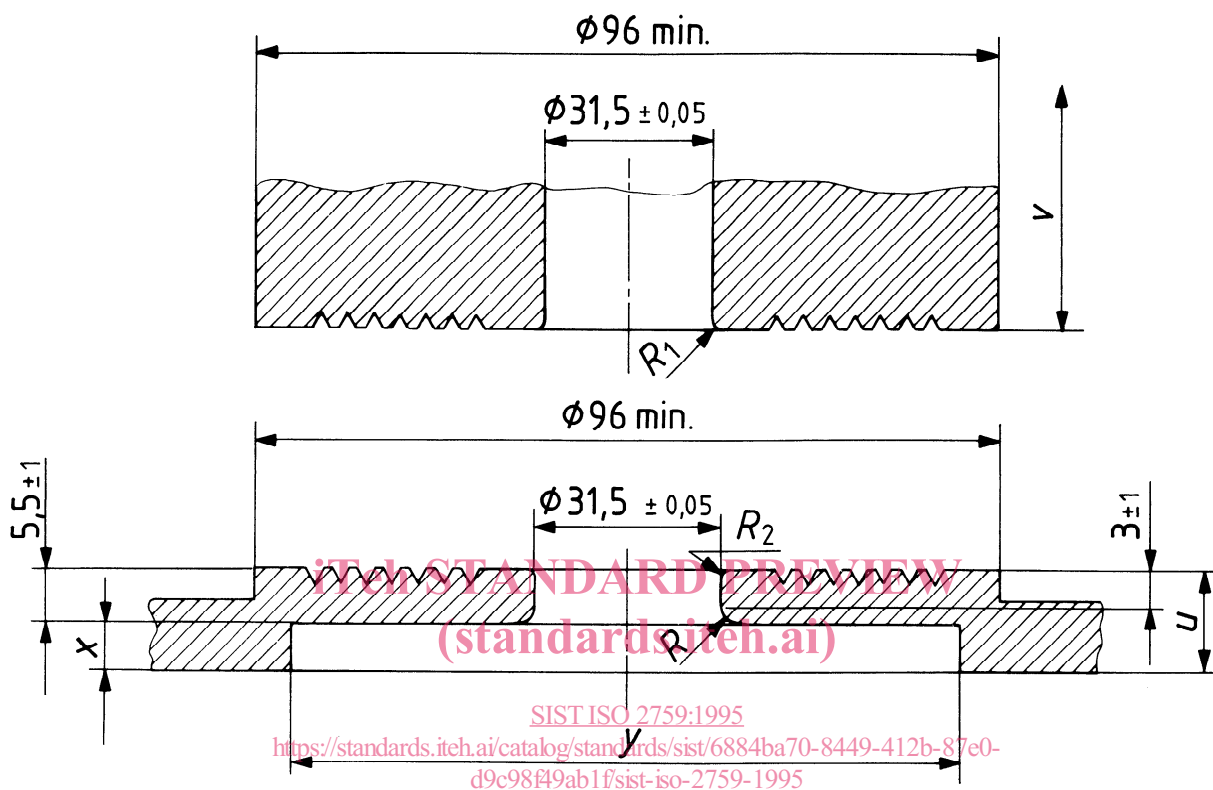

$R$ ,  $R_1$ ,  $R_2$ ,  $u$ ,  $v$ ,  $x$  and  $y$  are specified in the text.

Figure 1 – Clamps

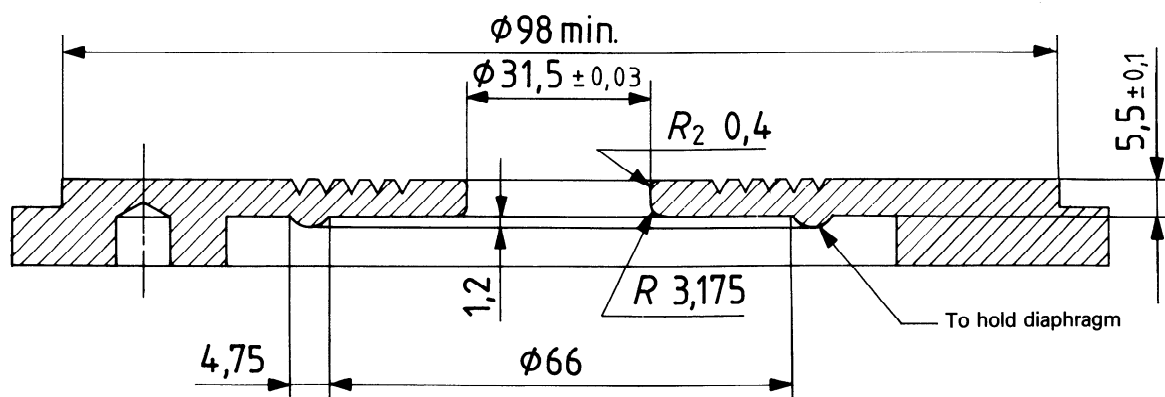
Figure 2 – Alternative lower clamp<sup>1)</sup>

1) This clamp may sometimes be found on instruments of North American manufacture.