



Designation: E1114 – 09^{ε1}

Standard Test Method for Determining the Size of Iridium-192 Industrial Radiographic Sources¹

This standard is issued under the fixed designation E1114; the number immediately following the designation indicates the year of original adoption or, in the case of revision, the year of last revision. A number in parentheses indicates the year of last reapproval. A superscript epsilon (ϵ) indicates an editorial change since the last revision or reapproval.

^{ε1} NOTE—Editorially corrected 2.2 and Figure 4 in June 2011.

1. Scope

1.1 This test method covers the determination of the size of an Iridium-192 radiographic source. The determination is based upon measurement of the image of the Iridium metal source in a projection radiograph of the source assembly and comparison to the measurement of the image of a reference sample in the same radiograph.

1.2 The values stated in either SI units or inch-pound units are to be regarded separately as standard. The values stated in each system may not be exact equivalents; therefore, each system shall be used independently of the other. Combining values from the two systems may result in non-conformance with the standard.

1.3 *This standard does not purport to address all of the safety concerns, if any, associated with its use. It is the responsibility of the user of this standard to establish appropriate safety and health practices and determine the applicability of regulatory limitations prior to use.*

2. Referenced Documents

2.1 ASTM Standards:²

- E999 Guide for Controlling the Quality of Industrial Radiographic Film Processing
- E1316 Terminology for Nondestructive Examinations
- E1815 Test Method for Classification of Film Systems for Industrial Radiography
- E2445 Practice for Qualification and Long-Term Stability of Computed Radiology Systems
- E2597 Practice for Manufacturing Characterization of Digital Detector Arrays

2.2 Other International Standards:

- EN 12679:2000 Industrial Radiography—Radiographic Method for the Determination of the Source Size for Radioisotopes³

3. Terminology

3.1 For definitions of terms relating to this test method, refer to Terminology E1316.

4. Significance and Use

4.1 One of the factors affecting the quality of a radiographic image is geometric unsharpness. The degree of geometric unsharpness is dependent upon the size of the source, the distance between the source and the object to be radiographed, and the distance between the object to be radiographed and the film or digital detector. This test method allows the user to determine the size of the source and to use this result to establish source to object and object to film or detector distances appropriate for maintaining the desired degree of geometric unsharpness.

NOTE 1—The European standard CEN EN 12579 describes a simplified procedure for measurement of source sizes of Ir-192, Co-60 and Se-75. The resulting source size of Ir-192 is comparable to the results obtained by this test method.

5. Apparatus

5.1 *Subject Iridium-192 Source*, the source size of which is to be determined. The appropriate apparatus and equipment for the safe storage, handling, and manipulation of the subject source, such as a radiographic exposure device (also referred to as a gamma ray projector or camera), remote control, source guide tube, and source stop are also required.

5.2 *Reference Sample (see Figs. 1-3)*—The reference sample shall be of material which is not radioactive. The recommended material is Iridium. However, substitutes such as platinum, tungsten or other material of similar radiopacity may be used. The sample should be of the same geometric shape as the subject source, should be approximately the same size as

¹ This test method is under the jurisdiction of ASTM Committee E07 on Nondestructive Testing and is the direct responsibility of Subcommittee E07.01 on Radiology (X and Gamma) Method.

Current edition approved June 1, 2009. Published July 2009. Originally approved in 1986. Last previous edition approved in 2003 as E1114 – 03. DOI: 10.1520/E1114-09E01.

² For referenced ASTM standards, visit the ASTM website, www.astm.org, or contact ASTM Customer Service at service@astm.org. For *Annual Book of ASTM Standards* volume information, refer to the standard's Document Summary page on the ASTM website.

³ Available from American National Standards Institute (ANSI), 25 W. 43rd St., 4th Floor, New York, NY 10036, http://www.ansi.org.

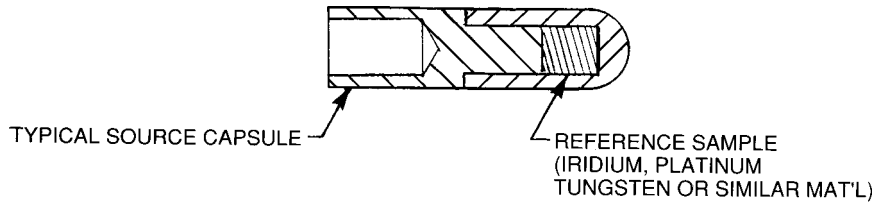

FIG. 1 Reference Sample in Standard Source Encapsulation

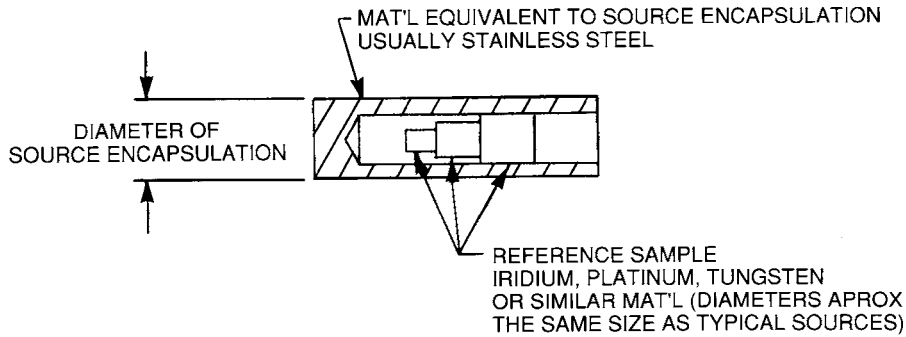

FIG. 2 Alternate Reference Sample Arrangement

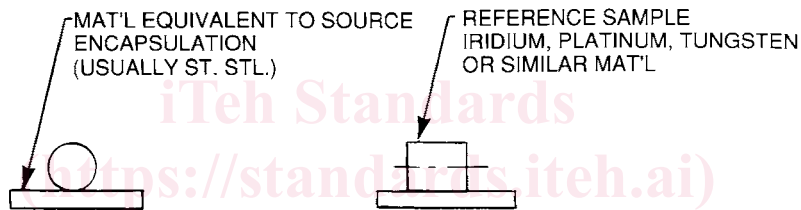

FIG. 3 Alternate Reference Sample Arrangement

the subject source, and should be positioned on or within a shim or envelope to simulate the source capsule wall. The resulting radiographic contrast, with reference to adjacent background density of the image of the reference sample, should be approximately the same as that of the subject source. The actual dimensions of the reference sample should be determined to the nearest 0.025 mm (0.001 in.).

5.3 *X-ray Generator*, capable of producing a radiation intensity (roentgen per hour at one metre) at least ten times greater than that produced by the subject source. Examples of typical X-ray generator output requirements that satisfy this criterion are presented in Table 1.

TABLE 1 Examples of Typical X-ray Generator Output Requirements for Related Iridium¹⁹² Source Activities

Subject Iridium ¹⁹² Source Radiation		Typical X-ray Generator Output Requirements	
Activity (Curie)	Output (R/h at 1 m)	Potential	Current
30	14.4	160 kV	5 mA
		200 kV	3 mA
100	48.0	160 kV	10 mA
		250 kV	4 mA
200	96.0	160 kV	20 mA
		250 kV	8 mA
		300 kV	6 mA

5.4 *Film systems*—Only film systems having cognizant engineering organization approval or meeting the system class requirements of Test Method E1815, for system classes I, II or Special, shall be used. Selection of film systems should be determined by such factors as the required radiographic quality level, equipment capability, materials and so forth. The film system selected shall be capable of demonstrating the required image quality. No intensifying screens shall be used. Radiographic films shall be processed in accordance with Guide E999.

5.5 *Image Measurement Apparatus*—This apparatus is used to measure the size of the image of the spot. The apparatus shall be an optical comparator with built-in graticule with 0.1 mm divisions or 0.001 in. divisions and magnification of 5× to 10×.

5.6 *Digital Detectors*—Digital detectors, which are either imaging plates or digital detector arrays, may be used as film replacement. The digital detector shall possess a pixel pitch which is at least 40 times smaller than the nominal source size to measure and a basic spatial resolution smaller than 1/20 of the nominal source size. The basic spatial resolution shall be measured in accordance with the procedure of Practice E2597 for DDAs or Practice E2445 for the imaging plate scanner system or taken from manufacturer statements. In the area of free beam a detector SNR_D > 100 shall be achieved. The measurement procedure of the SNR shall be in accordance with